



# SERVOTOUGH Oxy Operator Manual

Part Number: **01910001B**  
Revision: **10**  
Language: **UK English**



This page intentionally blank.

## IMPORTANT INFORMATION



Continued safe and reliable operation of this equipment is conditional on all installation, operation and maintenance procedures being carried out in accordance with the appropriate manuals, by personnel having appropriate qualifications, experience and training.

*Failure to observe the requirements of the manual may result in the user being held responsible for the consequences and may invalidate any warranty.*

*Servomex will accept no liability for unauthorised modifications to Servomex supplied equipment.*

*Servomex has paid particular attention to Health and Safety throughout this manual. Where special precautions need to be taken due to the nature of the equipment or product, an appropriate safety icon and warning message is shown. Special attention should be made to the Safety Chapter if available, where all such messages are summarised.*

*In line with our continuous policy of research and development, we reserve the right to amend models and specifications without prior notice.*

*This handbook is accurate at the date of printing, but will be superseded and should be disregarded if specifications or appearance are changed.*

*Servomex is a registered trademark of Servomex Group Limited. The use of all trademarks in this document is acknowledged.*

This page intentionally blank

# Table of Contents

<b>1. DESCRIPTION AND DEFINITIONS</b>	<b>1</b>
1.1 Description	1
1.2 Construction	1
1.2.1 Sample/control compartment:	1
1.2.2 Power/signal compartment (Figure 4):	2
1.3 Ordering options	2
<b>2. SPECIFICATION</b>	<b>9</b>
2.1 General	9
2.2 Environmental limits	9
2.3 Electrical data	11
2.4 Sample gas	12
2.5 Corrosive Purge gas	13
2.6 Calibration gas	13
2.7 Performance	14
2.8 Hazardous area certification	16
<b>3. UNPACK THE ANALYSER</b>	<b>19</b>
<b>4. ANALYSER USER INTERFACE</b>	<b>21</b>
4.1 Introduction	21
4.2 Start-up and measurement screens	21
4.3 Soft key legends	22
4.4 System and measurement status icons	23
4.5 Scroll bars	24
4.6 Menu options/screens and password protection	24
4.7 The Menu screen	26
4.8 The Settings screen	26
4.9 The Information screen	27
4.10 Editing on-screen data	28
<b>5. INSTALLATION AND SET-UP</b>	<b>29</b>
5.1 Mechanical installation	29
5.2 Remove the power/interface compartment cover	32
5.3 Electrical supply and interface signal connections	33
5.3.1 Electrical safety	33
5.3.2 Configure the cable entry holes	35
5.3.3 Interface signal connections	36

5.3.4	Auto Validate/Calibrate connections (option) .....	37
5.3.5	Modbus RS485 and ethernet connections (option) .....	39
5.3.6	Mains electrical supply connection .....	40
5.4	Refit the power/interface compartment cover .....	41
5.5	External earth (ground) connection .....	41
5.6	Connect the sample/calibration gas pipe(s).....	42
5.7	Switch on/set-up.....	44
5.8	Selecting the security level and password(s) .....	44
5.9	Setting the security level .....	45
5.10	Changing passwords.....	45
5.11	Adjusting the contrast .....	46
5.12	Adjusting the backlight timer .....	46
5.13	Setting the clock .....	46
5.14	Changing regional settings.....	47
5.15	Setting up automatic validation/calibration (option) .....	48
5.15.1	Overview of automatic validation/calibration .....	48
5.15.2	Automatic validation/calibration sequence.....	50
5.15.3	Remote calibration or automatic validation/calibration.....	51
5.15.4	Automatic validation/calibration target and tolerance .....	52
5.15.5	Automatic validation/calibration type and mode.....	53
5.15.6	Automatic validation/calibration phases.....	53
5.15.7	Automatic validation/calibration timers.....	55
5.16	Configuring and using the mA outputs .....	56
5.16.1	Overview.....	56
5.16.2	Introduction to the mA output parameters.....	57
5.16.3	Setting up the mA output parameters.....	59
5.16.4	Calibrating the mA output.....	61
5.17	Configuring and using the relay outputs.....	62
5.17.1	Overview relay default status settings.....	62
5.17.2	Setting up the relay coil status .....	63
5.18	Correcting O <sub>2</sub> measurements for background gases .....	65
5.18.1	Overview of measurement errors .....	65
5.18.2	Entering a cross-interference compensation .....	66
5.19	Selecting display units .....	66
5.20	Configuring the measurement alarms .....	68
5.20.1	Alarm modes and levels.....	68

5.20.2	Latching/non-latching alarms .....	70
5.20.3	Hysteresis levels.....	70
5.20.4	Viewing the measurement alarm status .....	71
5.20.5	Setting the Measurement Filter Level .....	71
5.21	Setting up the Flowcube (F <sup>3</sup> ) Flow Sensor (option).....	72
<b>6.</b>	<b>CALIBRATION .....</b>	<b>75</b>
6.1	Manual calibration.....	75
6.2	Automatic validation/calibration.....	76
6.2.1	Initiating an automatic validation/calibration .....	76
6.2.2	Automatic validation/calibration status indications.....	78
6.2.3	Stopping an automatic validation/calibration .....	78
6.2.4	Viewing validation/calibration history .....	79
6.2.5	Calibrating the pressure sensor.....	80
6.3	Calibrating the Flowcube (F <sup>3</sup> ) Flow Sensor (option).....	80
<b>7.</b>	<b>GENERAL OPERATION.....</b>	<b>81</b>
7.1	Checking the relay signal outputs .....	81
7.2	Pressure compensation (option) .....	82
7.2.1	Introduction.....	82
7.2.2	Switching pressure compensation on/off .....	82
7.2.3	Viewing pressure effected measurements.....	82
7.3	Checking the mA output .....	83
7.4	Viewing flow levels.....	83
7.5	Switching off the analyser .....	84
<b>8.</b>	<b>ROUTINE MAINTENANCE.....</b>	<b>85</b>
8.1	Cleaning the analyser .....	85
8.2	Inspection .....	85
8.3	Inspecting/replacing the fuse (when necessary) .....	86
8.4	Refit the power/interface compartment cover .....	87
8.5	Use of the analyser with toxic gases .....	88
8.6	Preventative maintenance.....	88
<b>9.</b>	<b>SAMPLE SYSTEM INTEGRATION.....</b>	<b>91</b>
9.1	Sample Systems .....	91
9.2	Corrosive Purge .....	91
<b>10.</b>	<b>FAULT FINDING.....</b>	<b>93</b>
10.1	Fault, Maintenance Required and SIP Statuses .....	93
10.1.1	Status definitions.....	93

10.1.2	Status Annunciations .....	93
10.2	Viewing messages .....	98
10.2.1	Active messages .....	98
10.2.2	View history messages .....	99
10.3	General fault finding.....	99
<b>11.</b>	<b>STORAGE AND DISPOSAL.....</b>	<b>103</b>
11.1	Storage.....	103
11.2	Disposal.....	103
<b>12.</b>	<b>SPARES .....</b>	<b>105</b>
<b>Appendix A</b>	<b>IMPLEMENTATION GUIDE FOR MODBUS COMMUNICATIONS .....</b>	<b>107</b>
A.1	Introduction .....	107
A.2	References .....	107
A.3	Modbus setup.....	107
A.4	Supported function codes .....	107
A.5	Exception codes .....	108
A.6	Addressing .....	108
A.7	Floating point numbers .....	108
A.8	System data mapping .....	108
A.9	Transducer data mapping .....	109
A.10	System fault mapping .....	110
A.11	Transducer fault and alarm mapping .....	111
A.12	System setup mapping .....	114
A.13	Transducer setup mapping .....	114
A.14	System control .....	117
A.15	Transducer control.....	118
<b>Appendix B</b>	<b>CONFIGURING THE MODBUS PARAMETERS .....</b>	<b>121</b>
B.1	RS485 .....	121
B.2	TCP (Ethernet).....	122
<b>Appendix C</b>	<b>DISPLAY UNIT CONVERSION FACTORS .....</b>	<b>125</b>
<b>Appendix D</b>	<b>PARAMAGNETIC CORRECTION FACTORS.....</b>	<b>127</b>
<b>Appendix E</b>	<b>MATERIALS IN CONTACT WITH SAMPLE AND CALIBRATION GASES.....</b>	<b>135</b>
<b>Appendix F</b>	<b>DISPOSAL IN ACCORDANCE WITH THE WASTE ELECTRICAL AND ELECTRONIC EQUIPMENT (WEEE) DIRECTIVE .....</b>	<b>137</b>
<b>Appendix G</b>	<b>COMPLIANCE AND STANDARDS INFORMATION .....</b>	<b>139</b>



## Table of Figures

Figure 1 - Front of the analyser .....	3
Figure 2 - Base of the Analyser.....	4
Figure 3 - Base of analyser, Sample Heating .....	5
Figure 4 - Inside Power / Signal Compartment .....	6
Figure 5 - Inside Power / Signal Compartment - Auto validation / Remote Calibration .....	7
Figure 6 - The Measurement screen .....	22
Figure 7 - The analyser menu structure .....	25
Figure 8 - The Menu screen.....	26
Figure 9 - The Settings screen .....	27
Figure 10 - Typical information screen .....	27
Figure 11 - A typical edit screen.....	28
Figure 12 - Fixing dimensions (mm) .....	31
Figure 13 - Fixing dimensions cont. (mm).....	32
Figure 14 - Modbus RS485 interface connector.....	40
Figure 15 - The Security level screen.....	45
Figure 16 - The Security select screen.....	45
Figure 17 - The Edit supervisor password screen.....	46
Figure 18 - The Contrast screen .....	46
Figure 19 - The Backlight timer screen.....	46
Figure 20 - The Clock (time) screen.....	47
Figure 21 - The Clock (date) screen .....	47
Figure 22 - The Regional settings (Language) option screen.....	48
Figure 23 - Typical automatic calibration sequence.....	51
Figure 24 - The Auto val/cal parameters screen.....	52
Figure 25 - The Auto val/cal low target value screen.....	52
Figure 26 - The Auto val/cal low tolerance screen.....	52
Figure 27 - The Auto val/cal high target value screen .....	53
Figure 28 - The Auto val/cal high tolerance screen.....	53
Figure 29 - The Auto val/cal type screen.....	53
Figure 30 - The Auto val/cal mode screen.....	53
Figure 31 -The Auto val/cal phase screen .....	54
Figure 32 - The Auto val/cal pre- warning timer screen.....	54
Figure 33 - The Auto val/cal inerting screen .....	54
Figure 34 - The Auto val/cal inert gas screen.....	54
Figure 35 - The Auto val/cal inerting timer screen.....	55
Figure 36 - The Auto val/cal flushing screen .....	55
Figure 37 - The Auto val/cal timer screen .....	55
Figure 38 - The Auto val/cal start date screen .....	55
Figure 39 - The Auto val/cal start time screen .....	56
Figure 40 - The Auto val/cal repeat time screen .....	56
Figure 41 - The mA configuration screen .....	59
Figure 42 - The mA range screen .....	59
Figure 43 - The mA output high level screen .....	60
Figure 44 - The during calibration screen .....	60
Figure 45 - The jam condition screen.....	60
Figure 46 - The mA output range screen .....	60

Figure 47 - The mA under range screen .....	61
Figure 48 - The mA range change point screen. ....	61
Figure 49 - The mA range change hysteresis screen.....	61
Figure 50 - The mA output service screen.....	62
Figure 51 - The mA output calibrate screen .....	62
Figure 52 - Fault Relay .....	63
Figure 53 - Maintenance Required .....	64
Figure 54 - Service in Progress .....	64
Figure 55 - Alarm 1 .....	64
Figure 56 - Alarm 2 .....	64
Figure 57 - mA Range Indication .....	65
Figure 58 - The X-Interference offset screen .....	66
Figure 59 - The Currently selected units screen .....	67
Figure 60 - The Units selection screen .....	68
Figure 61 - The Units conversion factor screen .....	68
Figure 62 - The Alarm set up screen.....	69
Figure 63 - The Alarm mode screen .....	69
Figure 64 - The Alarm follow screen.....	70
Figure 65 - The Alarm follow options screen.....	70
Figure 66 - The Alarm status screen .....	71
Figure 67 - Filter factor screen .....	72
Figure 68 - Filter Factor Edit Screen.....	72
Figure 69 - The low flow level 1 screen .....	73
Figure 70 - The low flow level 2 screen .....	73
Figure 71 - The low flow 1 status screen .....	74
Figure 72 - The low flow 2 status screen .....	74
Figure 73 - The high flow status screen.....	74
Figure 74 - The Calibrate screen .....	76
Figure 75 - The Calibrate target value screen.....	76
Figure 76 - The Auto val/cal select screen.....	77
Figure 77 - The Auto val/cal initiate screen .....	77
Figure 78 - The Auto val/cal confirm screen.....	77
Figure 79 - The Auto val/cal status screen (flushing phase).....	78
Figure 80 - The Auto val/cal status screen (validating phase).....	78
Figure 81 - The Auto val/cal status screen (finishing phase).....	78
Figure 82 - The Auto val/cal failed screen .....	78
Figure 83 - The Auto val/cal stop confirmation screen.....	79
Figure 84 - The validation/calibration history screen (initial view) .....	79
Figure 85 - The validation/calibration history screen (alternate view) .....	80
Figure 86 - The flow calibrate zero screen.....	80
Figure 87 - The flow calibrate normal screen .....	80
Figure 88 - The Relay override state screen .....	81
Figure 89 - The Relay override action screen .....	81
Figure 90 - The Pressure compensation .....	82
Figure 91 - The Pressure view screen .....	83
Figure 92 - The mA output override.....	83
Figure 93 - Flow levels .....	84
Figure 94 - The Message status screen .....	99

Figure 95 - The Message status screen ..... 99  
Figure 96 - Comms Parameters Mode Screen ..... 121  
Figure 97 - Comms Parameters Node address screen..... 121  
Figure 98 - Comms Parameters Baud rate screen ..... 122  
Figure 99 - Comms Parameters Parity screen ..... 122  
Figure 100 - Comms Parameters IP Address screen..... 122  
Figure 101 - Comms Parameters Subnet mask screen ..... 123  
Figure 102 - Comms Parameters Gateway address screen ..... 123

## About this manual

### Safety information

The following icons are used throughout this manual to identify any potential hazards that could cause serious injury to people or damage to the equipment:



This symbol warns of specific hazards which, if not taken into account, may result in personal injury or death.



*Les paragraphes « AVERTISSEMENT » contiennent des mises en garde contre des dangers de mort ou risques de blessure.*



This symbol warns of specific hazards from high temperatures.



*Ce symbole met en garde contre les dangers spécifiques liés aux températures élevées.*

### Other information provided by the manual



This symbol highlights where you must take special care to ensure the Analyser or other equipment or property is not damaged.

**Note:** *Notes give extra information about the equipment.*

<b>Hint:</b>	<i>Hints give helpful tips.</i>
--------------	---------------------------------

### Scope of the manual

This manual is the Operator Manual of the SERVOTOUGH Oxy. It provides installation, operation and routine maintenance instructions.

Other documents for the SERVOTOUGH Oxy are listed below:

Document	Description	Document number
Service Manual	SERVOTOUGH Oxy Service Manual	01910002B
Functional Safety Manual	SERVOTOUGH Oxy Functional Safety Manual	01910006B
Certification Manual	SERVOTOUGH Oxy Certification Manual	01910008B

# 1. DESCRIPTION AND DEFINITIONS

---

## 1.1 Description

The analyser is designed to provide stable, accurate and specific gas concentration measurements, and is suitable for use in hazardous areas.

The analyser uses a paramagnetic transducer to determine the oxygen (O<sub>2</sub>) content of gas samples in concentrations of up to 21% in any background mixture, including continuously flammable backgrounds.

The analyser is simple to operate, with an intuitive user interface.

Gas sample measurements are shown on the analyser display, and are also provided as milliamp (mA) outputs and via Modbus digital communication (RS485 and Ethernet). The analyser also provides fault, concentration, maintenance required and service in progress alarms and milliamp (mA) range indication via 30Vdc 1A relay signal outputs.

The analyser can also be equipped with an optional pressure sensor, Flowcube (F3) flow sensor technology, sample compartment heater and auto validation 30Vdc 1A relay signal outputs.

The analyser requires little routine maintenance, other than calibration (which is essential for the accuracy of sample gas measurements).

## 1.2 Construction

The analyser comprises an aluminium enclosure, with Viton® and silicone rubber seals.

Refer to Figure 1. The analyser has two internal compartments:

### 1.2.1 Sample/control compartment:

This compartment is accessed through the hinged door, on which the display and soft keys are mounted. It contains intrinsically safe components such as the sample measurement transducer, pressure sensor and sample compartment heater.

To ensure the stability of the measurement the transducer is maintained at approximately 65 °C (149°F).

Where fitted the pressure sensor is directly after the sample measurement transducer and compensates for both barometric and other pressure changes, i.e back pressure variations when venting to flare stacks and vent headers.

Where fitted the Flowcube (F3) flow sensor is directly after the sample measurement transducer, enabling accurate flow trending and alarm setting for many applications including safety critical applications. The flow sensor offers one high flow alarm and two low flow alarms which can be configured to be inactive or to indicate a fault or maintenance required status via the instrument relay outputs or Modbus digital communication.

Where fitted sample compartment heating allows samples with dew points of up to 50°C to be directly sampled by the analyser and give greater robustness of the analyser to sample system upsets and fluctuations.

The sample gas inlet and outlet connections on the base of the analyser (see Figure 2) are piped into/from this compartment and contain sintered stainless steel particulate filters, designed to give extra

protection to the measurement transducer. They also form part of the analysers elevated sample pressure (124kPa (18psia)) hazardous area certification and the analyser should not be vented to pressures over 110 kPa (16psia) without these fitted. They are external to the analyser and simple to change in the case of contamination. When sample compartment heating is fitted these sintered elements are also heated to 70°C, giving further robustness to moisture droplets or aerosols carried over from the sample system.

During normal operation, calibration and installation it is not required to access this side of the enclosure.

### **1.2.2 Power/signal compartment (Figure 4):**

This explosion-proof compartment contains the components which supply power to the rest of the analyser, and the components to interface the analyser to your control/monitoring system.

These components include the mA outputs, Modbus digital communication (RS485 or Ethernet) and 30 Vdc 1A relay signal outputs which provide fault, concentration, maintenance required, service in progress alarms, mA range indication, and optional auto validation control.

The analyser electrical supply cable, and the communications cables to your control/monitoring system, must be connected (through the cable entry holes on the base of the analyser) to the terminals in this compartment.

You must remove the threaded cover to access this compartment.

## **1.3 Ordering options**

For the latest ordering options please contact your local Servomex agent or visit [www.servomex.com](http://www.servomex.com).

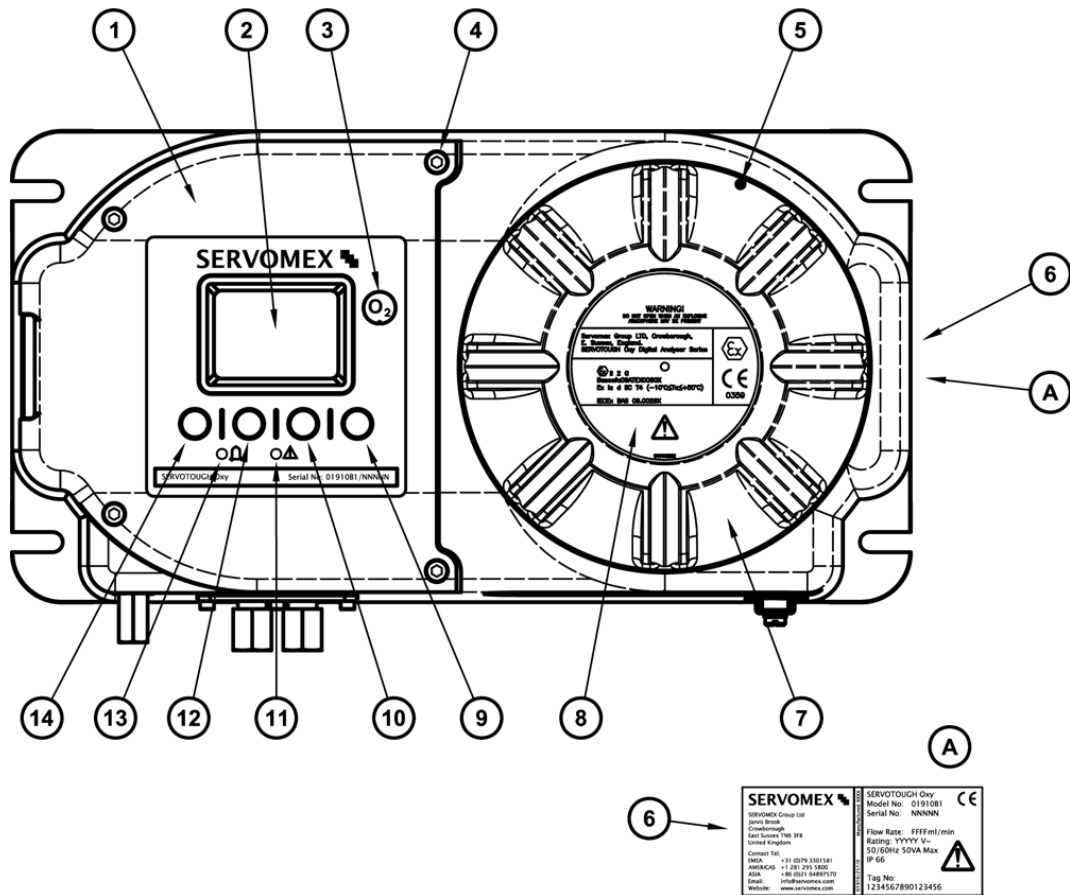
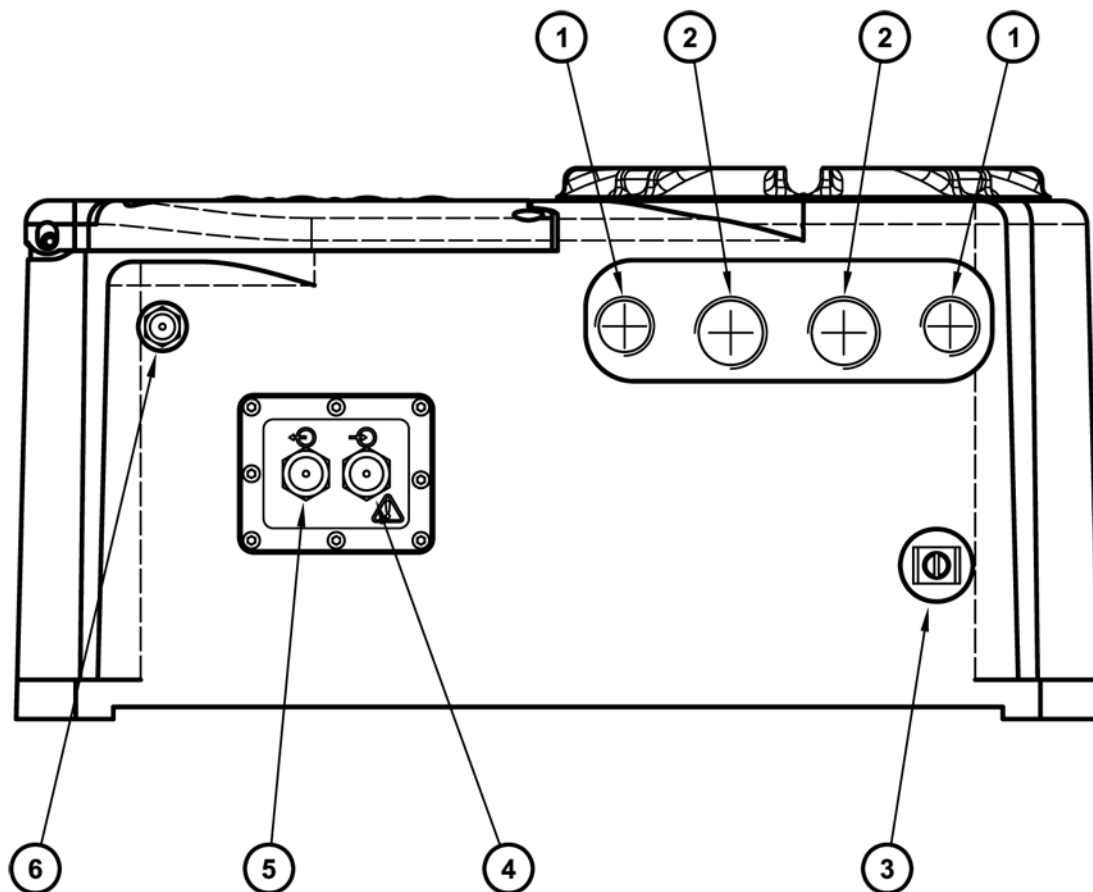

Figure 1 - Front of the analyser

Key	Description	Key	Description
1.	Hinged cover	8.	Certification label
2.	Display	9.	Soft key 4
3.	Sample gas label	10.	Soft key 3
4.	Locking screws (4 off)	11.	Fault LED (red)
5.	Locking screw *	12.	Soft key 2
6.	Identification/rating label †	13.	Alarm LED (yellow)
7.	Threaded cover	14.	Soft key 1

\* The locking screw may be in a different orientation with respect to the cover (7), depending on how the cover has been fitted.

† On the side of the analyser. Contains Servomex contact details, date of manufacture, analyser model and serial number, analyser inlet flow rate, mains voltage rating and optional Tag Number.



**Figure 2 - Base of the Analyser**

Key	Description	Key	Description
1.	Cable entry holes (2 off) 1/2 inch NPT	4.	Sample gas inlet 1/4 inch NPT
2.	Cable entry holes (2 off) 3/4 inch NPT	5.	Sample gas outlet 1/4 inch NPT
3.	Functional Earth (ground) terminal	6.	Corrosive purge inlet 1/4 inch NPT, or blank



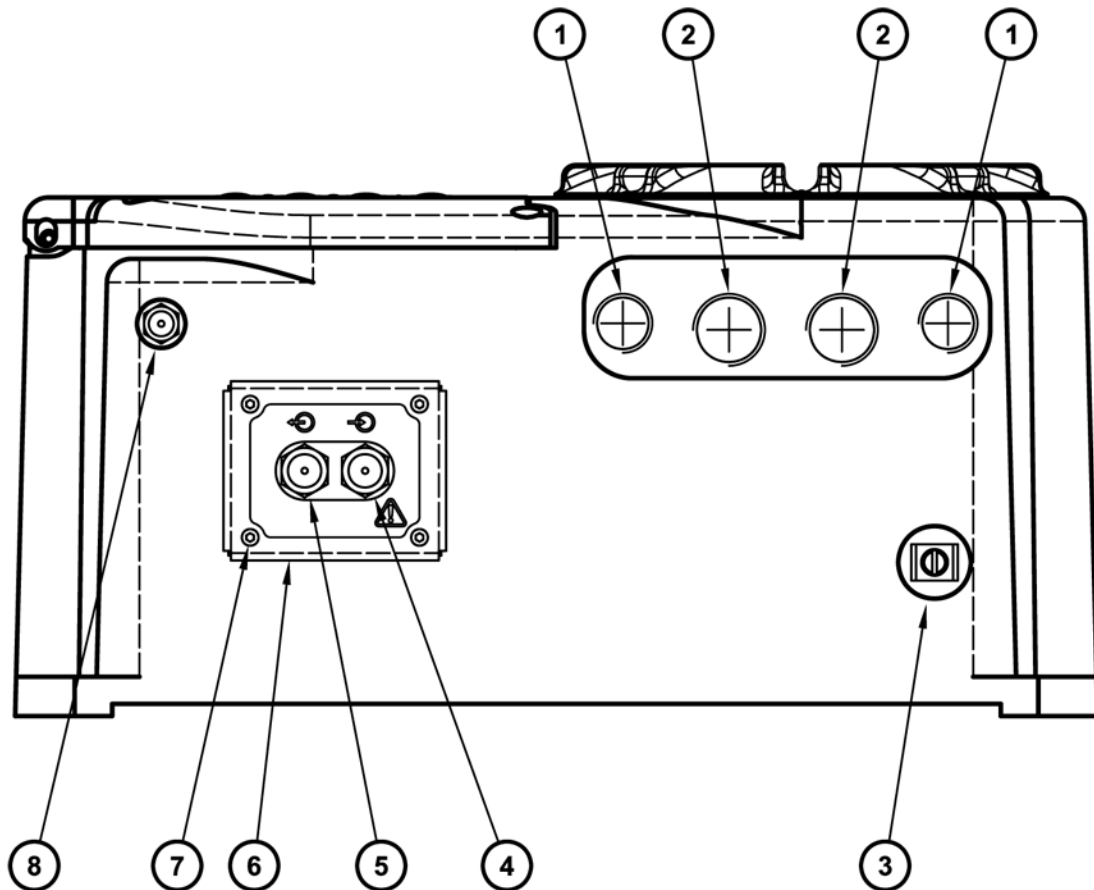

**Figure 3 - Base of analyser, Sample Heating**

Key	Description	Key	Description
1.	Cable entry holes (2 off) 1/2 inch NPT	5.	Sample gas outlet 1/4 inch NPT
2.	Cable entry holes (2 off) 3/4 inch NPT	6.	Sample inlet/outlet insulation and cover plate
3.	Functional Earth (ground) terminal	7.	Cover plate fixing screw, 4 x M4
4.	Sample gas inlet 1/4 inch NPT	8.	Corrosive purge inlet 1/4 inch NPT, or blank

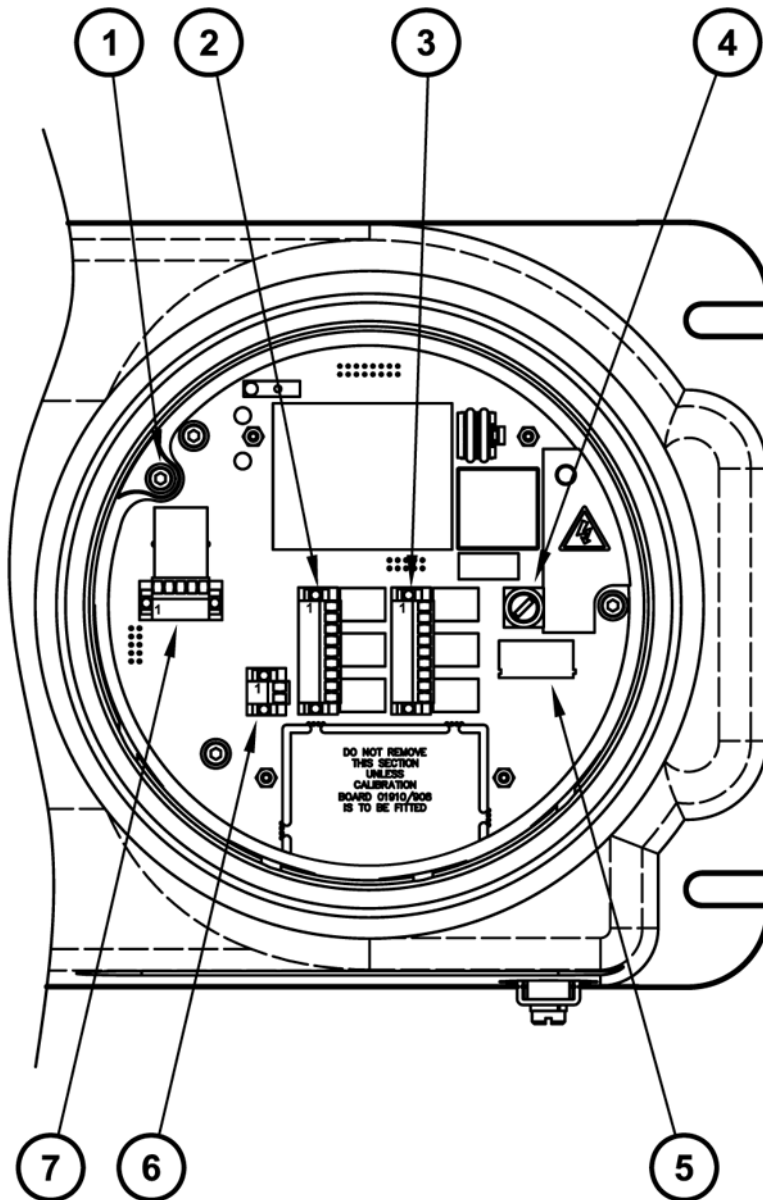

**Figure 4 - Inside Power / Signal Compartment**

Key	Description	Key	Description
1.	Earth (ground) connection	5.	Electrical Supply P101
2.	Relays P112, relay functions: mA range indication, Service in Progress and Maintenance Required	6.	mA output terminals P103
3.	Relays P102, relay functions: Concentration Alarms 1& 2 and Fault	7.	Modbus 485 (P109) or Ethernet (U152) connection
4.	Fuse F101		

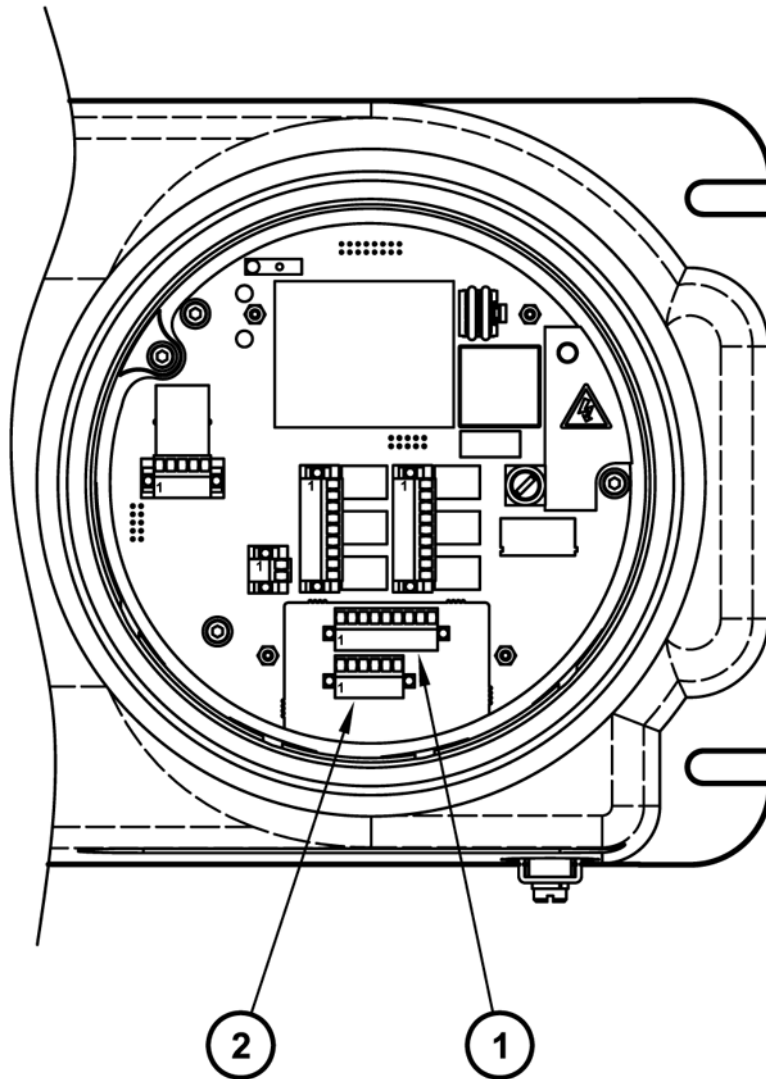

**Figure 5 - Inside Power / Signal Compartment - Auto validation / Remote Calibration**

<b>Key</b>	<b>Description</b>	<b>Key</b>	<b>Description</b>
1.	Relay P803, relay functions: Sample gas, low calibration gas and high calibration gas	2.	Switch inputs P804, auto validation, autocalibration, calibrate low, calibrate high and initiate service in progress

This page intentionally blank.

## 2. SPECIFICATION



You must install and use the analyser in accordance with the requirements of this and subsequent sections of the manual. If you do not, people may be injured, the protection facilities incorporated into the design of the analyser may not operate as intended, sample gas measurements may not be accurate, or the analyser may be damaged.



*Vous devez installer et utiliser l'analyseur en conformité avec les exigences de cette section et des sections suivantes de ce manuel. Dans le cas contraire, vous risquez de provoquer des accidents, d'altérer le fonctionnement des protections incorporées, de diminuer la précision des mesures ou d'endommager l'analyseur.*

### 2.1 General

Analyser Dimensions	235 x 448 x 227 mm (height x width x depth)
Standard mounting	See Figure 12 and Figure 13
Mass	>26 kg (See Section 5.1 for Installation advice)

### 2.2 Environmental limits



The installation of the analyser in a hazardous area must comply with any 'Special conditions for safe use' and/or 'Schedules of Limitations' as specified in the safety certification. See Certification Supplement Manual Part Number: 01910008B.



*L'installation de l'analyseur dans une zone dangereuse doit se conformer à toutes les conditions spéciales de sécurité (« Special conditions for safe use ») et/ou à la grille de limitations (« Schedules of Limitations ») telles que détaillées dans le certificat de sécurité. Voir manuel de certification supplémentaire (référence 01910008B, « Certification Supplement Manual »).*



The analyser is not suitable for use with oxygen enriched sample gases, that is gases over 21% O<sub>2</sub>, relative to atmospheric pressure. If used with gases containing over 21% O<sub>2</sub> the hazardous area certification is invalidated.



*L'analyseur ne convient pas pour une utilisation avec des gaz échantillon enrichis en oxygène, c'est-à-dire avec une teneur en O<sub>2</sub> de plus de 21 % par rapport à la pression atmosphérique. En cas d'utilisation avec des gaz contenant plus de 21 % d'oxygène, la certification d'agrément pour zones dangereuses est invalidée.*



During operation the analyser is rated -10 to 55°C (14°F to 131°F), outside these temperature limits the measurement performance will be effected and outside -10 to 60°C (14°F to 140°F) the hazardous area certification is invalidated. If ambient temperatures are likely to exceed either of these temperature limits, actions must be taken to install the analyser within a temperature controlled environment.



*Pendant le fonctionnement, l'analyseur est évalué à -10 à 55 °C (14 °F à 131 °F), en dehors de ces limites de température, les performances de mesure seront affectées et en dehors de -10 à 60 °C (14 °F à 140 °F), la certification de zone dangereuse est invalidée. Si les températures ambiantes sont susceptibles de dépasser l'une de ces limites de température, des mesures doivent être prises pour installer l'analyseur dans un environnement à température contrôlée.*



The analyser is not suitable for use with sample vent back pressures that cause pressurisation at the sample vent of greater than 124 kPa (18 psia). If used with gases at pressures over 124 kPa (18 psia) the hazardous area certification is invalidated.



*L'analyseur ne peut être utilisé avec des contre-pressions à l'évent d'évacuation de l'échantillon supérieures à 124 kPa (18 psia). En cas d'utilisation à des pressions de plus de 124 kPa (18 psia), la certification d'agrément pour zones dangereuses est invalidée.*

---

Ambient temperature range	
Operation	-10 to 55°C (14°F to 131°F)
Storage	-20 to 60 °C (-4°F to 140°F)
<hr/>	
Operating ambient pressure range	79 to 110 kPa (11 to 16 psi absolute)
<hr/>	
Operating ambient humidity range	0 to 95% RH, non-condensing
<hr/>	
Operating altitude range	-500 * to 2000 † meters
<hr/>	
Ingress protection	IP66 / NEMA 4X

---

\* Below sea level.

† Above sea level.

Analyser is suitable for outdoor use within the limits stated above.

## 2.3 Electrical data

---

### Electrical supply

- Voltage 100 to 120 Vac or 220 to 240 Vac (+/-10%) \*
  - Frequency 50/60 Hz
- 

Maximum power consumption 50 VA

---

### Internal fuse rating

- 100 to 120 V supply T 2.0 A H 250 V
  - 220 to 240 V supply T 1.0 A H 250 V Electrical supply conductor size
- 

Flexible conductors 0.5 to 2.5 mm<sup>2</sup> (20 to 14 AWG)

---

Solid conductors 0.5 to 2.5 mm<sup>2</sup> (20 to 14 AWG)

---

Interface signal relay ratings ‡ 30 Vdc 1 A

---

### Milliamp output

- Maximum load resistance 600 W
  - Minimum isolation voltage 500 V
- 

### Output range

- Normal sample measurement 0 to 20 mA or 4 to 20 mA †
  - Fault condition 0 mA or 21.5 mA †
  - Under range # < 4 mA
- 

### Switched Inputs

- Input Voltage and Current \$ 12 to 24 Vdc; 5 to 15 mA
  - Minimum operating time ~ 0.5 seconds (Momentary Inputs)
  - Maximum operating time ~ Infinite
- 

Signal/milliamp/RS485 output terminals suitable for:

- Flexible conductors 0.5 to 1.5 mm<sup>2</sup> (20 to 16 AWG)
  - Solid conductors 0.5 to 1.5 mm<sup>2</sup> (20 to 16 AWG)
-

\* The analyser is supplied configured for operation with one of these voltage ranges. You must specify the voltage range when you order the analyser.

‡ The relay output signals are volt-free signals.

† User selectable.

# Only available when the 4 to 20 mA output range is selected.

\$ Switch contacts should be suitable for low current switching.

~ For Initiate and Stop of Auto validation, Autocalibration, Calibrate Low and Calibrate High, a momentary input of 0.5 seconds or longer is required, i.e. momentary push button switch. To activate and deactivate Service in Progress, a latching action switch is required.

## 2.4 Sample gas



The analyser is not suitable for use with oxygen enriched sample gases, that is gases over 21% O<sub>2</sub>, relative to atmospheric pressure.



*L'analyseur ne convient pas pour une utilisation avec des gaz échantillon enrichis en oxygène, c'est-à-dire avec une teneur en O<sub>2</sub> de plus de 21 % par rapport à la pression atmosphérique.*



The analyser is not suitable for use with sample vent back pressures that cause pressurisation at the sample vent of >124 kPa (18 psia).



*L'analyseur ne peut être utilisé avec des contre-pressions à l'évacuation de l'échantillon de >124 kPa (18 psia).*



The analyser will be damaged if condensation is allowed to form within the measurement cell or pipe work. It is important that the sample gas dew points specified below are maintained at all times.

**Note:** *The sample gases must be clean, non-corrosive, free from oil/condensates and compatible with the materials listed in Appendix A5*



---

#### Flow rates

- Standard inlet/outlet † 150 to 250 ml min<sup>-1</sup> (200 ml min<sup>-1</sup> recommended)
  - High flow bypass † 50 to 70 l h<sup>-1</sup> (60 l h<sup>-1</sup> recommended)
- 

#### Maximum sample vent pressure

- Standard inlet/outlet † 124.0 kPa (18.0 psia)
  - High flow bypass † 122.8 kPa (17.8 psia)
- 

#### Maximum inlet pressure

- Standard inlet/outlet † 0.2kPa (0.03psi) relative to sample vent pressure
  - High flow bypass † 1.4kPa (0.2psi) relative to sample vent pressure
- 

Sample dew point (without optional sample compartment heating) 5 °C (9°F) below ambient temperature (minimum)

---

Sample dew point (with optional sample compartment heating) 50 °C (122°F) maximum

---

Particulate size < 3 mm (3 micron)

---

† The pressure and flow of sample gases must be externally regulated to meet the above requirements.

## 2.5 Corrosive Purge gas

**Note:** *The purge gases must be inert, clean, non-corrosive, free from oil/condensates. Instrument air or nitrogen is recommended.*

---

Flow rate	40 to 60 ml min <sup>-1</sup>
Dew point	5 °C (9°F) below ambient temperature (minimum)
Maximum purge pressure	110 kPa (16 psia)

---

## 2.6 Calibration gas

**Note:** *The calibration gases must be clean, non-corrosive, free from oil/ condensates and compatible with the materials listed in Appendix A5.*

**Note:** *For optimum calibration results, the calibration gas flow rate/pressure should be the same as the flow rate/pressure of the gases to be sampled.*

O <sub>2</sub> transducer calibration gases	
• High calibration setpoint	0.5 to 20.95% O <sub>2</sub>
• Low calibration setpoint	0 (99.5% zero grade nitrogen recommended)
• Minimum Difference	0.5%
• Low calibration tolerance level *	
• Calibration gas < 5% O <sub>2</sub>	± 0.5% O <sub>2</sub>
• Calibration gas ≥ 5% O <sub>2</sub>	± 10% Calibration target value
• High calibration tolerance level *	
• Calibration gas < 5% O <sub>2</sub>	± 0.5% O <sub>2</sub>
• Calibration gas ≥ 5% O <sub>2</sub>	± 10% Calibration target value

\* If the measurement is outside the specified range, a fault message is stored to indicate that there may be a problem (for example, the wrong calibration gas has been introduced, or the transducer has drifted excessively). The fault can be over-ridden to allow the calibration to take place.



It is recommended that sample/calibration gas flow is monitored to ensure a representative sample is being measured

## 2.7 Performance

**Note:** *The display indications given below are the default indications. You can configure the analyser to provide other display indications (see Section 5.19).*

The display indications given below are the default indications. You can configure the analyser to provide other display indications (see Section 5.19).

---

## Oxygen Measurement

---

Display indication	Measured volume % oxygen
Measurement ranges	from 0 to 1% to 0 to 21% oxygen
Lower Detection Limit	<±50ppm oxygen
Linearity	No measurable error
Repeatability	±0.02% oxygen
Intrinsic error (accuracy)	<±0.05% oxygen (based on 95% confidence limits)
Zero drift per week	< 0.05% oxygen
Span drift per week	< 0.05% oxygen
Output fluctuation (peak to peak)	< 0.01% oxygen
T90 response time	< 6 seconds (at 200 ml min <sup>-1</sup> and 1 l min <sup>-1</sup> )
Sample flow effect: (50 - 250 ml min <sup>-1</sup> or 12 - 70 l hr <sup>-1</sup> )	zero < 0.1% oxygen span < 0.5% reading
Zero temperature coefficient:	<±0.03% oxygen per 10 °C (18°F) change in temperature

### Sample vent pressure effects:

Pressure compensation not fitted	1% change in sample vent pressure corresponds to 1% change in reading
Pressure compensation fitted	1% change in sample vent pressure corresponds to 0.05% change in reading.

### Flowcube (F3) Flow Sensor

Intrinsic Error	<±5% of full scale for 100% N2* (based on 95% confidence limits)
Resolution	1% of full scale
Span temperature coefficient:	<±2% of full scale per 10 °C (18°F) change in temperature
T90 response time	< 15 seconds
Recommended Calibration Interval	6 to 12 months

\* For gases with higher molecular weights than N2, the accuracy will be <±10% of full scale.

## 2.8 Hazardous area certification



Refer to Certification supplement manual 01910008B.



*Reportez-vous au manuel de supplément de certification 01910008B.*

Copies of the Hazardous Area Certificates are held in Certification supplement manual 01910008B. In summary, the SERVOTOUGH Oxy is certified for use in Zone 1/Division 1 areas (both gases and dusts) and is available with the following hazardous area approvals:

### Europe

The analyser is ATEX approved to:

⊕ II 2 GD

Ex db ia IIC T4 Gb (-10 °C ≤ Ta ≤ +60 °C) Ex tb IIIC T90 °C Db (-10 °C ≤ Ta ≤ +60 °C)

Certificate number: Baseefa09ATEX0080X

### Great Britain

The analyser is UKEX approved to:

⊕ II 2 GD

Ex db ia IIC T4 Gb (-10 °C ≤ Ta ≤ +60 °C) Ex tb IIIC T90 °C Db (-10 °C ≤ Ta ≤ +60 °C)

Certificate number: BAS21UKEX0479X

### International

The analyser is IECEx approved to:

Ex db ia IIC T4 Gb (-10 °C ≤ Ta ≤ +60 °C) Ex tb IIIC T90 °C Db (-10 °C ≤ Ta ≤ +60 °C)

Certificate number: IECEx BAS 09.0029X

### North America

The analyser is CSA approved for use in North America in the following locations:

Class I, Division 1, Groups A, B, C, D T4

Class II, Division 1, Groups E, F, G

Class III,

Ex ia d IIC T4

Ex tD T90 °C

AEx ia d IIC T4

AEx tD T90 °C

(-10 °C ≤ Ta ≤ +60 °C)

Certificate number: CSA 1961540

## Japanese

The analyser is CML approved to:

Ex db ia IIC T4 Gb (-10 °C ≤ Ta ≤ +60 °C) Ex tb IIIC T90 °C Db (-10 °C ≤ Ta ≤ +60 °C)

Certificate number: CML 20JPN1113X

This page intentionally blank.

### 3. UNPACK THE ANALYSER

---



The analyser is heavy (see Section 2.1). Care must be taken when handling, see Section 5.1 for Mechanical Installation guidance.



*L'analyseur est lourd (voir Section 2.1). Des précautions doivent être prises lors de la manipulation, voir la section 5.1 pour les conseils d'installation mécanique.*

1. Remove the analyser and any other equipment from its packaging.
2. Inspect the analyser and the other items supplied, and check that they are not damaged. If any item is damaged, immediately contact Servomex or your local Servomex agent.
3. Check that you have received all of the items that you ordered. If any item is missing, immediately contact Servomex or your local Servomex agent.
4. Check that you have also received an accessory kit, containing the following:

Quantity	Item	Check (3)
1	2 mm hexagonal key	o
1	5 mm hexagonal key	o
2	Spare fuses	o

If the accessory kit is missing, or any item is missing from the kit, immediately contact Servomex or your local Servomex agent.



Check that the electrical supply voltage (shown on the rating label) is correct for your electrical supply. If the incorrect voltage is shown, do not continue to install the analyser; instead, contact Servomex or your Servomex agent.



Check that the sample inlet gas flow rate (shown on the rating label) is correct, if not contact Servomex or your Servomex agent, as the measurement maybe damaged by excessive flow rates.

**Note:** *Retain the shipping documentation and packaging for future use (for example, return of the analyser to Servomex for servicing or repair).*

This page intentionally blank.



## 4. ANALYSER USER INTERFACE

---

**Note:** Throughout this manual, reference is made to product ordering options (such as "Auto validation" or "pressure compensation") which must be specified at the time of purchase. Associated menus and menu options will not be available if your analyser does not have the corresponding product options.

### 4.1 Introduction

The analyser user interface comprises the following (shown on Figure 1):

Display	Shows various screens: see Section 4.2 onwards.
Soft keys	The function of each of the soft keys depends on the screen currently being shown on the display: see Section 4.3.
Alarm LED	On when an alarm condition exists: see Section 5.20.
Fault LED	On when a fault condition exists: see Section 10.

### 4.2 Start-up and measurement screens

When you first switch on the analyser, a 'start-up screen' is displayed while the analyser carries out a self-test.

The start-up screen shows the Servomex name, a 'self-test time elapsed/remaining' indicator, and messages identifying the tasks being carried out as part of the self-test.

The screen will initially display the "System Check" task message. The Measurement screen is then displayed, as shown in Figure 6 below.

## Measurement screen:

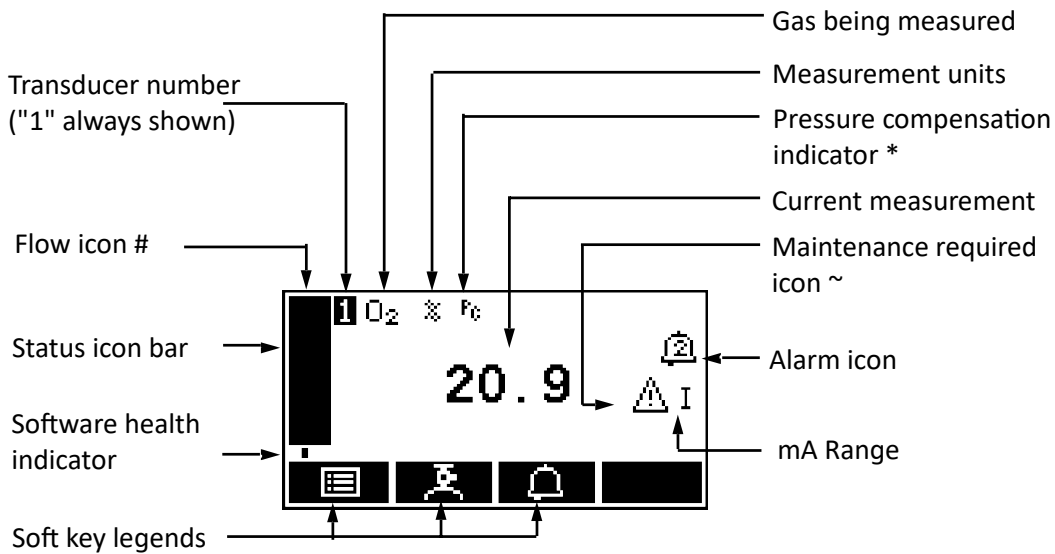

\* Only shown when unit is installed with pressure compensation installed and is on: see Section 7.2.

# Only shown when unit is installed with flow sensor option.

~ Measurement status, either Maintenance required, Service in Progress or Fault.





**Figure 6 - The Measurement screen**

**Note:** During normal analyser operation, the software health indicator continuously moves from left to right and then back again, below the status icon bar. If the indicator stops moving, this means that the analyser is not operating correctly, and you must refer to Section 10.

**Note:** If no soft key is pressed for 10 minutes, the Measurement screen will be automatically displayed. You will also then have to enter the password again to access any password-protected screens.









### 4.3 Soft key legends

The four soft key legends at the bottom of the Measurement screen (Figure 6) correspond to the four soft keys on the front of the analyser. (The first, left-most, legend corresponds to the function of soft key 1, the second legend corresponds to the function of soft key 2, and so on). On the Measurement screen, the soft key functions are as follows:

Legend	Meaning	Function (when soft key pressed)
	Menu	Displays the Menu screen
	Calibrate*	Displays the Calibrate screen
	Alarm*	Displays the Alarm option screen
		None (no effect)

\* These soft keys are 'shortcuts' to the described functions, which are also accessible from the menu structure.





Other soft key legends which are used on the various screens are as follows:

Legend	Meaning	Function (when soft key pressed)
	Back	Cancels the current screen and displays the previous screen in the menu structure
	Accept	Accepts the currently selected option or data (A new screen may be displayed accordingly)
	Edit	Allows the highlighted data to be edited
	Up	Moves the cursor up a list (or increases a digit during editing)
	Down	Moves the cursor down a list (or decreases a digit during editing)
	Left	Moves the cursor left
	Right	Moves the cursor right
	Stop	Stops an automatic validation/calibration

#### 4.4 System and measurement status icons

System status is on the status icon bar and can be shown with a fault icon or a maintenance required icon, see table below.



Measurement status is on the right-hand side of the measurement reading and can be shown with a fault icon, a maintenance required icon, a service in progress icon or a warning icon, see table below.

Icon	Meaning
	Indicates that a <b>fault</b> has been detected
	Indicates that <b>maintenance is required</b>
	Indicates that <b>service is in progress</b>
	Indicates that the analyser is <b>warming up</b>

To determine the cause of these status icons, see Section 10.1.2

## 4.5 Scroll bars

On some screens (for example, see Figure 8), there may be more options available than can be shown on the screen, and you have to scroll down the screen to view all of the options: this is identified by a scroll bar at the right-hand side of the screen.

The height of the wide part of the scroll bar gives an indication of what proportion (of all the options) are currently shown on the screen. As you scroll up or down the options (using the  and  soft keys), the wide part of the scroll bar will also move on the screen, indicating approximately where the currently displayed options are, within the complete list of options.

## 4.6 Menu options/screens and password protection

The menu structure of the analyser is shown in Figure 7, which indicates that some of the options/screens are password protected.

When an option/screen is password protected, this means that the correct corresponding password has to be entered before the option/screen can be accessed.

Password protection operates as follows:

**Note:** *As supplied, the security level is set to 'high', the supervisor password is set to "2000" and the operator password is set to "1000".*

- The first time you try to access a password-protected option/screen, you will be prompted for the corresponding password. You must then enter the correct password before the option/screen can be displayed.
- If you have already entered the corresponding password, you will gain access to all options/screens protected by that password immediately (you do not need to enter the password again).

**Note:** *Once you have entered a password, it remains active until 10 minutes after the last soft key is pressed. After this, the password becomes inactive; you must re-enter the password to access password-protected options/screens again.*

To change the passwords, see Section 5.10.

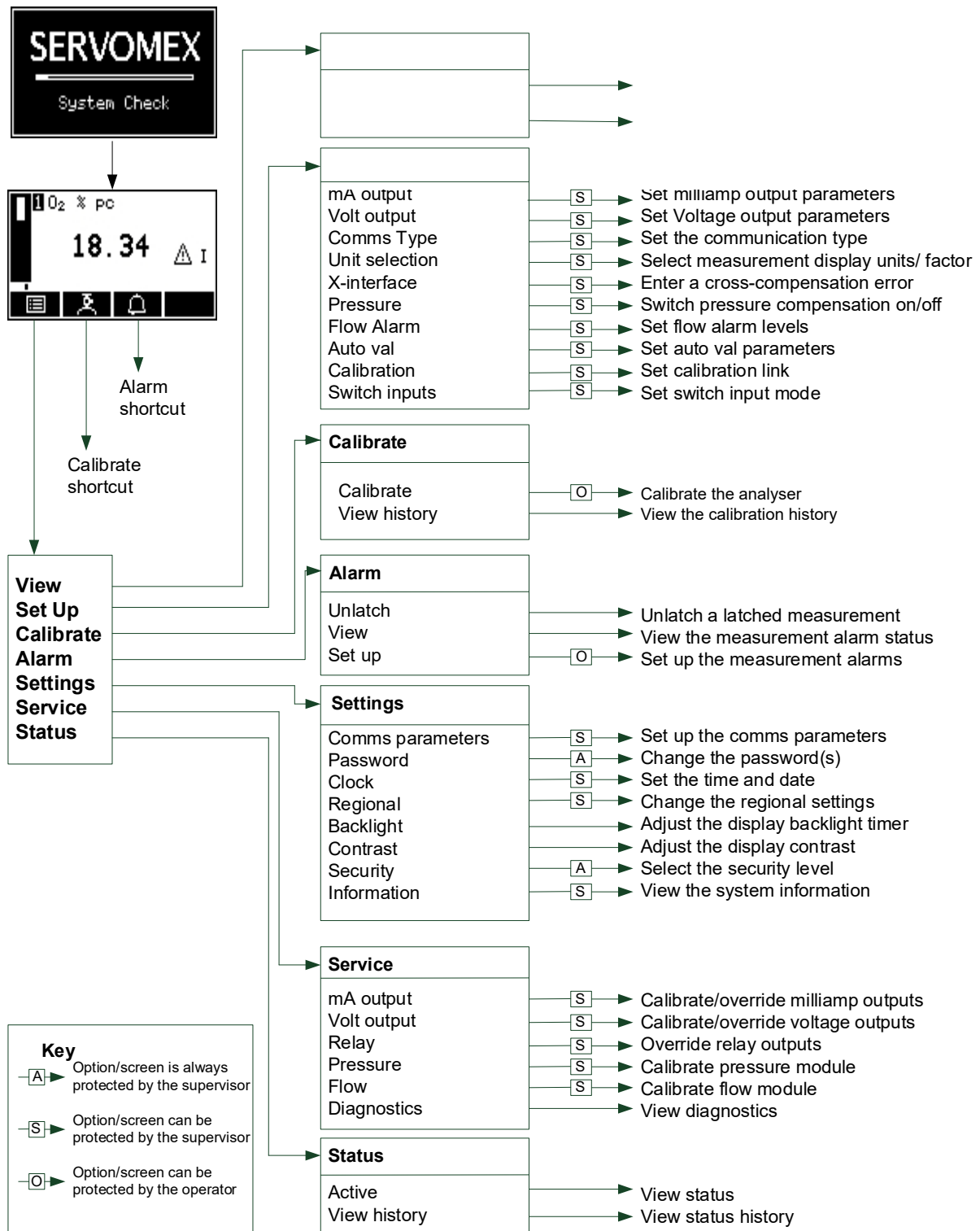



Figure 7 - The analyser menu structure

## 4.7 The Menu screen

**Note:** Some of the menu screens referenced below may not be available: refer to the note at the start of Section 4.

The Menu screen provides access to other screens in the menu structure, and is displayed by pressing the  soft key when the Measurement screen is displayed.

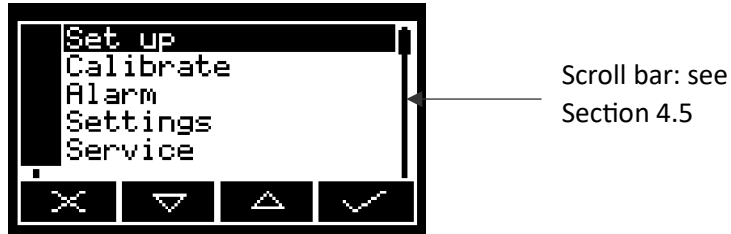







Figure 8 - The Menu screen

Use the  and  soft keys to highlight the required screen option, then press the  soft key to display the selected screen:

Screen	Use
View	Select this screen to view the O <sub>2</sub> measurement pre and post pressure compensation readings and the percentage flow level.
Set up	Select this screen to select the communications type, configure the auto validation/calibration target range, enter a cross-interference compensation, switch pressure compensation on/off, select the display units, set up flow sensor parameters and trip levels, set up the mA output parameters and ranges and the relay energised or deenergised settings.
Calibrate	Select this screen to calibrate or validate the analyser and to view calibration history.
Alarm	Select this screen to set up the measurement alarms and set the alarm follow options, unlatch alarms and view the measurement alarm status.
Settings	Select this screen to change analyser settings (password, display language and so on).
Service	Select this screen to calibrate/check the mA outputs and check the relay signal outputs.
Status	Select this screen to view active and historical fault, maintenance required and service in progress (SIP) messages.

Alternatively, press the  soft key to display the Measurement screen again.

## 4.8 The Settings screen

Use the  and  soft keys to highlight the required screen option, then press the  soft key to display the selected screen, as shown below:

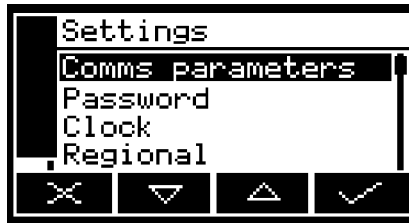

Figure 9 - The Settings screen

Screen	Use [refer to section]
Comms Parameters	Configuring the communications parameters [ B.1 or B.2 ]
Password	Changing the password [5.10]
Clock	Setting the clock time and/or date [5.13]
Regional	Changing regional settings (language and so on) [5.14]
Backlight	Adjusting the backlight timer duration [5.12]
Contrast	Adjusting the contrast of the screen [5.11]
Security	Selecting the security level [5.9]
Information	Viewing analyser system information [4.9]

Alternatively, press the  soft key to display the Menu screen again.

## 4.9 The Information screen

This screen shows information (such as the analyser serial number and the version of the operating software embedded in the analyser) which is useful to the Servomex support team.

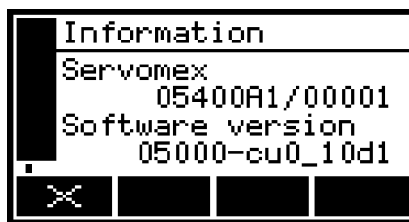



Figure 10 - Typical information screen

Note that the information shown on the screen will vary, depending on the analyser model.

After viewing (and if necessary recording) the information shown on the screen, press the  soft key to display the Settings screen again, or press and hold the  soft key to show the Measurement screen again.

**Note:** You may be asked to provide the information from this screen to the Servomex support team; for example, as an aid to fault diagnosis.

## 4.10 Editing on-screen data

A common method is used for editing data shown on all of the different screens.





When you press the  soft key to edit an item of data, the screen changes to show the corresponding edit screen, with the first digit highlighted:



**Figure 11 - A typical edit screen**

When the first digit is highlighted, press the  soft key to exit the menu without changing the data.

Alternatively, use the soft keys to edit the data as follows:

Soft key	Function
	Increases the highlighted digit by 1
	Decreases the highlighted digit by 1
	Moves the cursor left to the previous digit
	Moves the cursor right to the next digit

Note that the figures above and below the highlighted digit shows the digits above and below the currently highlighted value.

When the last digit is highlighted, press the  soft key to enter the new data.

**Note:** When editing numerical values, the decimal point appears between digits "9" and "0".



## 5. INSTALLATION AND SET-UP

---



You must not modify the analyser in any way (either mechanically or electrically). If you do, the certification of the analyser will be invalidated, and it may not operate safely.



*Vous ne devez pas modifier l'analyseur de quelque façon que ce soit (mécanique ou électrique). Dans le cas contraire, la certification est invalidée et la sécurité d'utilisation de l'analyseur compromise.*



The analyser must be installed by a suitably skilled and competent technician or engineer in accordance with this manual and to the special conditions of installation contained within the Certification Supplement Manual, Part Number: 01910008B.



*L'analyseur doit être installé par un technicien ou ingénieur compétent et dûment formé conformément à ce manuel et aux conditions d'installation spéciales contenues dans le manuel de certification supplémentaire (référence 01910008B, « Certification Supplement Manual »).*

### 5.1 Mechanical installation



The analyser is not suitable for use with oxygen enriched sample gases, that is gases over 21% O<sub>2</sub>, relative to atmospheric pressure,



*L'analyseur ne convient pas pour une utilisation avec des gaz échantillon enrichis en oxygène, c'est-à-dire avec une teneur en O<sub>2</sub> de plus de 21 % par rapport à la pression atmosphérique.*



The analyser is not suitable for use with sample vent back pressures that cause pressurisation at the sample vent of 124 kPa (18 psia).



*L'analyseur ne peut être utilisé avec des contre-pressions à l'évacuation de l'échantillon de 124 kPa (18 psia).*



You must ensure that, when the analyser is in its installation location:

- The operating environment is within the limits specified in Section 2.2.
- There is sufficient space around the analyser to install and connect the electrical supply (also see Section 5.3.1) and interface signal cables, and the sample inlet and outlet pipes.
- There is sufficient space to access the internal compartments for maintenance.
- The unit must be mounted so that dust may only form a layer on the top surface.

- To avoid propagating brush discharges, the unit is not to be installed in a high velocity dust-laden atmosphere.



*Les conditions suivantes doivent impérativement être réunies là où vous installez l'analyseur :*

- *L'environnement d'utilisation respecte les limites spécifiés à la Section 2.2.*
- *Il y a un espace suffisant autour de l'analyseur pour installer et connecter l'alimentation électrique et les câbles de signaux d'interface ainsi que les tuyaux d'entrée et de sortie d'échantillon.*
- *Il y a un espace suffisant pour accéder aux compartiments internes à des fins d'entretien.*
- *L'unité doit être montée de sorte que la poussière s'accumule sur le dessus uniquement.*
- *En raison du risque de propagation d'aigrettes, l'unité ne doit pas être installée dans une atmosphère chargée de poussières à haute vitesse.*



Do not install the analyser on a surface which is subject to high levels of vibration or sudden jolts. If you do, sample measurements may not be accurate, or the analyser may be damaged.



You must mount the analyser on a suitable rigid vertical surface capable of supporting 104 kg (refer to Section 2.1 for the mass of the analyser). Due to the Analyser mass, care must be taken during mounting, see below.

Note the following when you install a sample conditioning system:

- Locate the sample conditioning system below the analyser, to prevent the carry-over of condensate into the analyser sample measurement transducer.
- Ensure that the sample conditioning system will not impact on the environmental limits of the analyser (see Section 2.2).

To mount the analyser on a rigid vertical surface, attach the fixing lugs on the analyser to suitable bolts or hooks to securely mount the analyser: refer to Figure 12 and Figure 13 for the fixing dimensions.

Fixing lugs are suitable for M8 studs or bolts (Grade 8.8 or above) with a standard washer.



Lifting Instructions:

Analyser should not be lifted by one person alone. Where possible it is suggested to lift the analyser with suitable lifting apparatus such as a hoist. PPE (Personal Protective Equipment) such as safety shoes should be used to protect any persons from injury.

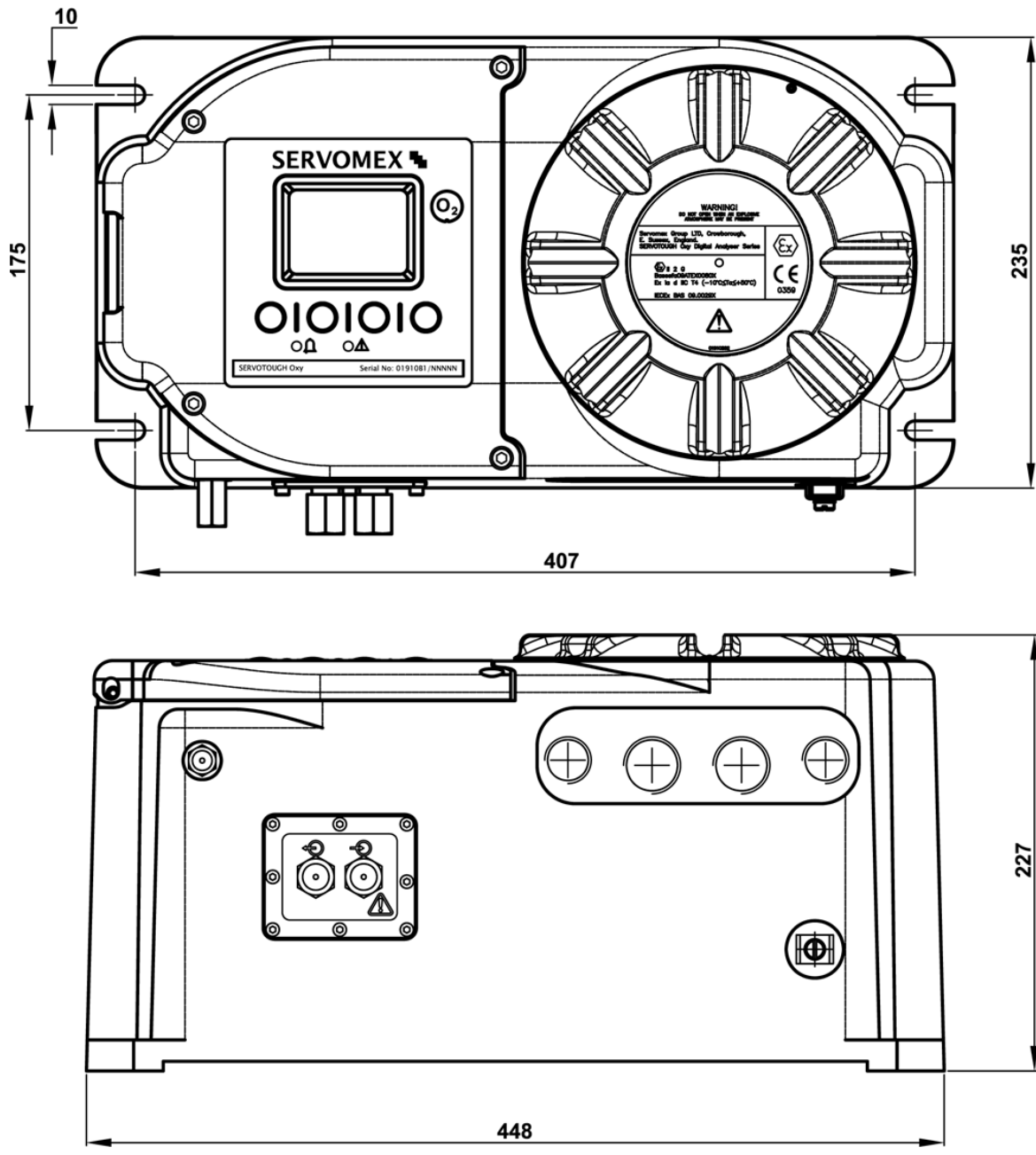

Figure 12 - Fixing dimensions (mm)

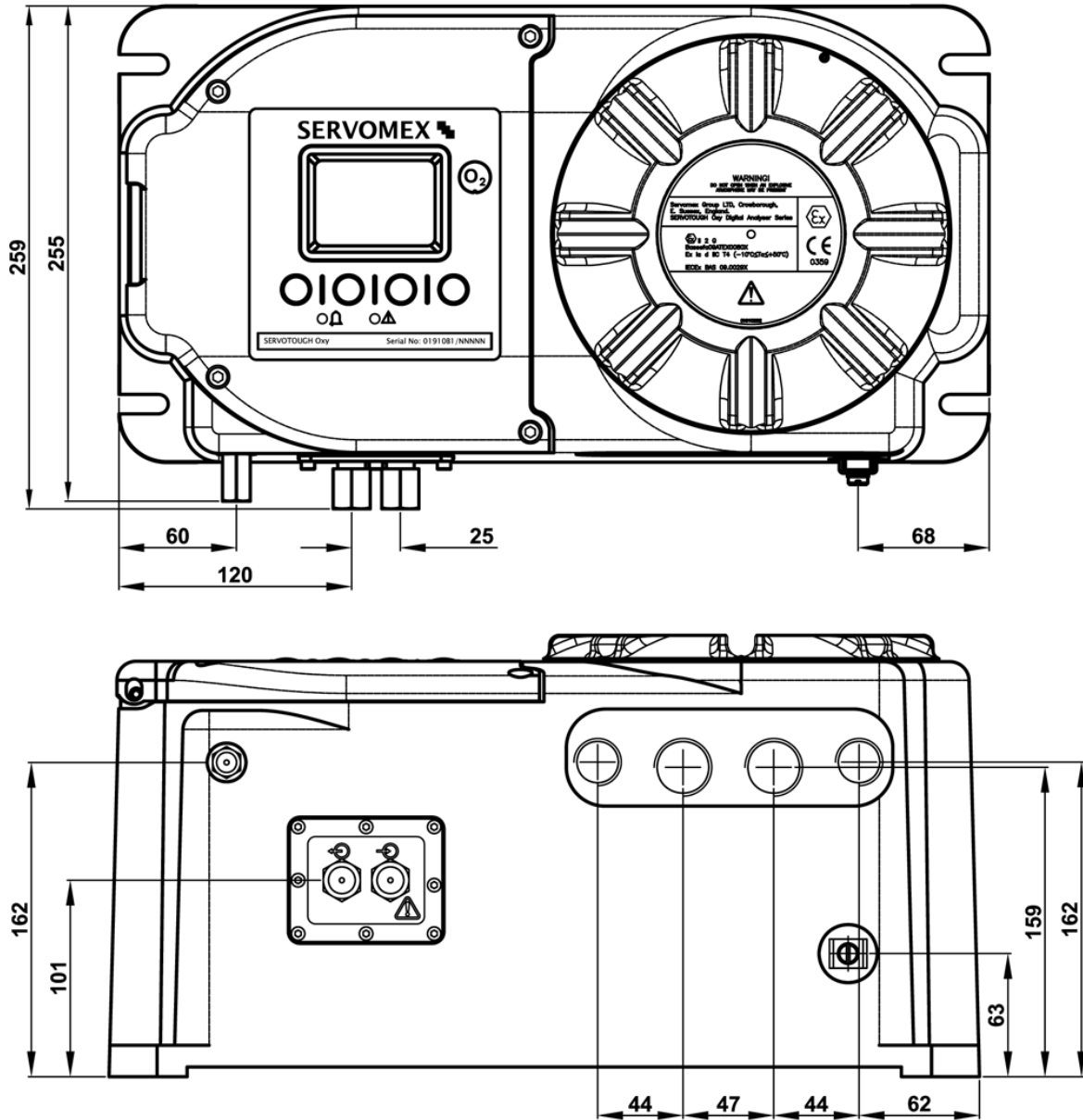

Figure 13 - Fixing dimensions cont. (mm)

## 5.2 Remove the power/interface compartment cover



The power/interface compartment cover is heavy. Ensure that you do not drop the cover once it is disengaged from the body of the analyser. If you do, you may injure yourself or damage other equipment. Any damage to the thread on the cover will compromise the analyser certification.



*Le couvercle du compartiment alimentation/interface est lourd. Veillez à ne pas le faire tomber après l'avoir dégagé du corps de l'analyseur. Vous risqueriez de vous blesser et d'endommager les autres équipements. Toute détérioration du filetage du couvercle invalidera la certification de l'analyseur.*



Place the cover carefully on a clean surface, resting on the exterior of the cover, so that the pregreased threads do not become contaminated.

1. Refer to Figure 1. Use the 2 mm hexagonal key supplied to loosen the locking screw which secures the cover.
2. Unscrew the cover; that is, turn it anticlockwise. If necessary, fit a suitable metal bar between the protruding fins on the front of the cover to provide additional leverage.
3. When the cover is fully disengaged from the body of the analyser, remove it and place it carefully on a clean surface: see the caution above.

## 5.3 Electrical supply and interface signal connections

### 5.3.1 Electrical safety



Ensure that the electrical installation of the analyser conforms with all applicable local and national hazardous area and electrical safety requirements.



*Assurez-vous que l'installation électrique de l'analyseur se conforme à toutes les exigences « zones dangereuses » locales et nationales en vigueur en matière de sécurité électrique.*



Obey the safety instructions given below when you install the analyser; if you do not, the analyser certification may be invalidated, the analyser may not operate correctly, or it may be damaged.

- All cables connected to the power/signal compartment must be connected to equipment which is not supplied from, or contain in normal or abnormal operating conditions, a source of potential with respect to earth (ground) higher than 253 Vac or 253 Vdc. As such it is recommended that the analyser is connected to a "grounded neutral" supply.
- The analyser does not incorporate an integral on/off switch. You must provide a means of externally isolating the electrical supply from the analyser: use a suitable switch or circuit breaker located close to the analyser, clearly marked as the disconnecting device for the analyser. This switch/circuit breaker must be easily operated with no obstructions.
- The electrical supply circuit must incorporate a suitable fuse or over-current protection device, set to or rated at no more than 10 A.
- The analyser must be connected to an external protective earthing system, using the Protective Earth on terminal P101.

- The analysers Earth (ground) connection located on the base of the analyser must be equipotentially bonded locally to the analyser.
- Ensure that your electrical supply can provide the necessary maximum power consumption: refer to Section 2.3.
- The volt-free relay contacts are isolated from the analyser mains circuits and from each other, only 30 Vdc 1A max signal voltage circuits can be connected to the contacts.
- The mA output and RS485 terminals are separated from the analyser mains circuits by reinforced insulation. The terminals must only be connected to circuits that are themselves separated from mains voltages by at least reinforced insulation.
- All signal and electrical supply cables must be rated for temperatures of 70°C (158°F) or higher.
- Ensure that the cables that you connect to the analyser are routed so that they do not present a trip hazard.
- When you carry out insulation testing, disconnect all cables from the analyser.



*Observez toutes les consignes de sécurité ci-après lors de l'installation de l'analyseur, sous peine d'invalider la certification, d'entraver le bon fonctionnement de l'analyseur ou de l'endommager.*

- *Les câbles connectés au compartiment alimentation/signalisation ne doivent en aucun cas être raccordés à des équipements alimentés par (ou susceptibles de contenir dans des conditions de fonctionnement normales ou anormales) une source de potentiel de plus de 253 V c.a. ou 253 V c.c. par rapport à la terre. Il est donc recommandé de connecter l'analyseur à une alimentation de type « neutre à la terre ».*
- *Il n'y a pas d'interrupteur marche/arrêt intégré à l'analyseur. Vous devez prévoir un moyen externe d'isoler la source d'alimentation électrique de l'analyseur, à l'aide d'un interrupteur ou d'un disjoncteur adapté situé à proximité de l'analyseur et clairement étiqueté comme le dispositif de coupure de l'analyseur.*
- *Le circuit d'alimentation électrique doit comporter un fusible ou dispositif approprié de protection contre les surintensités de 10 A maximum.*
- *L'analyseur doit être raccordé à un système de terre de protection externe via la terre de protection sur la borne P101.*
- *La connexion de terre située sur la base de l'analyseur doit être reliée localement de façon équipotentielle à l'analyseur.*
- *Votre source d'alimentation doit pouvoir supporter la consommation électrique maximum (voir Section 2.3).*
- *Les contacts de relais sans tension sont isolés des circuits d'alimentation électrique de l'analyseur et les uns des autres ; seuls des circuits de tension de signalisation de 30 V c.c. 1 A maximum peuvent être connectés aux contacts.*

- *Les bornes de sortie mA et RS485 sont séparées des circuits d'alimentation électrique de l'analyseur par un dispositif d'isolement renforcé. Ces bornes ne doivent être reliées qu'à des circuits qui sont eux-mêmes isolés de la tension secteur par un dispositif au moins équivalent.*
- *Les câbles électriques et câbles de signal doivent tous être classés pour des températures de 70 °C ou plus.*
- *Les câbles connectés à l'analyseur doivent être disposés de sorte qu'ils ne risquent pas de faire trébucher le personnel.*
- *Lors des essais d'isolement, débranchez tous les câbles de l'analyseur.*

### 5.3.2 Configure the cable entry holes



If the analyser is installed in a hazardous area, all cable-glands, adaptors and blanking plugs must be suitably approved. For the purposes of selecting suitable gland entry devices the flameproof Ex d enclosure shall be considered to have a volume of >2 litres.

- UKEX approved analysers, for gland entries, suitable UKEX or ATEX Flameproof Equipment certified gland entry devices shall be used. The gland entry device shall meet or exceed the EPL, Gas Group, IP rating and temperature range markings on the approval label.
- ATEX approved analysers, for gland entries, suitable ATEX Flameproof Equipment certified gland entry devices shall be used. The gland entry device shall meet or exceed the EPL, Gas Group, IP rating and temperature range markings on the approval label.
- IECEx approved analysers must be fitted with IP66 IECEx Ex d IIC approved components.
- CSA North American Approved analysers must be fitted with CSA/UL, cULus or cCSAus 4X, Class I, Groups A, B, C, D approved components.



*Si l'analyseur est installé dans une zone dangereuse, tous les presse-étoupes, adaptateurs et obturateurs doivent être agréés.*

- *Des analyseurs agréés UKEX, pour les entrées de presse-étoupe, des dispositifs d'entrée de presse-étoupe certifiés UKEX ou ATEX pour équipement antidéflagrant appropriés doivent être utilisés. Le dispositif d'entrée de presse-étoupe doit respecter ou dépasser les marques EPL, groupe de gaz, indice IP et plage de température sur l'étiquette d'approbation.*
- *Des analyseurs agréés ATEX, pour les entrées de presse-étoupe, des dispositifs d'entrée de presse-étoupe certifiés ATEX pour équipement antidéflagrant appropriés doivent être utilisés. Le dispositif d'entrée de presse-étoupe doit respecter ou dépasser les marques EPL, groupe de gaz, indice IP et plage de température sur l'étiquette d'approbation.*
- *Les analyseurs IECEx doivent être équipés de composants agréés IP66 IECEx Ex d IIC.*

- *Les analyseurs agréés CSA pour l'Amérique du Nord doivent être équipés de composants agréés CSA/UL, cULus ou cCSAus 4X, classe I, groupes A, B, C, D.*

The analyser has two 3/4 inch and two 1/2 inch NPT cable entry holes. As supplied, three of these holes are fitted with blanking plugs (rated to IP66 / NEMA 4X).

Configure the analyser so that the entry holes that you use for the electrical supply and signal connection cables have suitable cable-glands (and/or adaptors) fitted, and so that any unused entry hole has a blanking plug fitted.

All cable-glands/adaptors and plugs used must provide ingress protection to IP66, NEMA 4X or better. It is important that the correct cable gland is selected based on the cable size used in the installation. Refer to the manufacturer's data sheet for cable gland selection criteria.

**Note:** *It is recommended that the 1/2 inch NPT cable entry hole on the far right hand side of the enclosure is used for the power supply cable.*

### 5.3.3 Interface signal connections



All of the analyser interface signal outputs are considered to be incensive and therefore must only be connected to safe area equipment.



*Toutes les sorties de signaux d'interface de l'analyseur sont considérées comme inflammables et doivent donc exclusivement être connectées à des équipements pour zones dangereuses.*



To comply with EMC requirements, you must use a screened 4 to 20 mA cable to connect to the mA output. It is recommended that screens are terminated at the cable gland.

Connect the wires in your cables to the appropriate terminals as described below and refer to Section 2.3 for detailed ratings and cable sizes.

1. Pass your signal cable(s) through one or two of the cable-glands fitted to the base of the power/interface compartment.
2. Refer to Figure 4. Connect the mA output wires in your cables to the corresponding terminal pins of the mA output, as follows:

Signal	Terminal pin
+ve	P103 Pin 1
-ve	P103 Pin 2

3. Refer to Figure 4. Connect the relay signal output wires in your cables to the appropriate terminals for the corresponding relay, as shown below. Note that both N/O (normally open) and N/C (normally closed) signals are available for each relay.



The default relay configuration is shown below. The relays can either be set up to be energised or deenergised during normal operation. Refer to Section 5.17 for changing the relay set up and configuration and default states.

Relay	Signal	Terminal pin	Use
Alarm 1	N/C	P102 Pin 1	<b>Open</b> indicates an alarm condition
	COM	P102 Pin 2	(Common)
	N/O	P102 Pin 3	<b>Closed</b> indicates an alarm condition
Alarm 2	N/C	P102 Pin 4	<b>Open</b> indicates an alarm condition
	COM	P102 Pin 5	(Common)
	N/O	P102 Pin 6	<b>Closed</b> indicates an alarm condition
Fault *	N/C	P102 Pin 7	<b>Closed</b> indicates a fault condition
	COM	P102 Pin 8	(Common)
	N/O	P102 Pin 9	<b>Open</b> indicates a fault condition

\* As default the Fault relay is configured "Fail Safe", i.e. is permanently energised in normal operation.

Relay	Signal	Terminal pin	Use
mA Range indication	N/C	P112 Pin 1	<b>Closed</b> indicates a Range 1 and open indicates Range 2
	COM	P112 Pin 2	(Common)
	N/O	P112 Pin 3	<b>Open</b> indicates a Range 1 and closed indicates Range 2
Service in progress (SIP)	N/C	P112 Pin 4	<b>Open</b> indicates a SIP condition
	COM	P112 Pin 5	(Common)
	N/O	P112 Pin 6	<b>Closed</b> indicates a SIP condition
Maintenance Required	N/C	P112 Pin 7	<b>Open</b> indicates a maintenance required
	COM	P112 Pin 8	(Common)
	N/O	P112 Pin 9	<b>Closed</b> indicates a maintenance required

#### 5.3.4 Auto Validate/Calibrate connections (option)



The auto validate/calibrate board connections are separated from the analyser mains circuits by reinforced insulation. The terminals must only be connected to circuits that are themselves separated from mains voltages by at least reinforced insulation.



*Les connexions de validation/calibrage automatique sont séparées des circuits d'alimentation électrique de l'analyseur par un dispositif d'isolement renforcé. Ces*

*bornes ne doivent être reliées qu'à des circuits qui sont eux-mêmes isolés de la tension secteur par un dispositif au moins équivalent.*

The analyser can be supplied with auto-validate/calibrate relays and switched inputs. The relays can control solenoid valves in the gas supply system to perform validate or calibrate routines.

Depending on whether you have chosen to do a Remote Validate/Calibrate routine or an Auto Validate/Calibrate (see Section 6 and Section 6.2) the pin assignments will have different functions.

**Note:** *Unlike the relays detailed in Section 5.3.3, the autovalidate/calibrate relays cannot have their default configuration changed in any way.*

Relay	Signal	Terminal pin	Use
Sample Gas*	N/O	P803 Pin 1	<b>Open</b> to isolate sample gas flow
	COM	P803 Pin 2	(Common)
	N/C	P803 Pin 3	<b>Closed</b> to isolate sample gas flow
Low Calibration Gas	N/O	P803 Pin 4	<b>Closed</b> to start low calibration gas flow
	COM	P803 Pin 5	(Common)
	N/C	P803 Pin 6	<b>Open</b> to start low calibration gas flow
High Calibration Gas	N/O	P803 Pin 7	<b>Closed</b> to start high calibration gas flow
	COM	P803 Pin 8	(Common)
	N/C	P803 Pin 9	<b>Open</b> to start high calibration gas flow

\* The Sample Gas relay is configured "Fail Safe", i.e. is permanently energised in normal operation. If there is a power supply failure to the analyser, then the relay state will change and the sample gas flow to the analyser will be isolated. This helps to protect the analyser against sample corrosion during power interruptions.

Digital Input	Signal	Terminal pin	Use
Initiate Auto Validation / Auto Calibration / Calibrate	+ve	P804 Pin 1	+12V to 24V to start
Low <b>(Momentary Input)</b>	-ve	P804 Pin 2	0V
Stop Auto Validation / Auto Calibration / Calibrate High	+ve	P804 Pin 3	+12V to 24V to start
<b>(Momentary Input)</b>	-ve	P804 Pin 4	0V
Initiate Service in Progress	+ve	P804 Pin 5	+12V to 24V to start



### Figure 14 - Modbus RS485 interface connector

**Note:** Link pins 4 and 5 if the analyser is at the end of the RS485 network.

## If Modbus Ethernet option is supplied:

1. The cable should not leave the building in which it is installed without suitable isolation.
2. The cable must be screened CAT5E with standard RJ45 connectors.

### 5.3.6 Mains electrical supply connection



Ensure that the analyser as supplied is correctly configured for your mains electrical supply voltage. If the analyser is not correctly configured for your mains electrical supply voltage, the analyser may not operate correctly, or it may be damaged when you operate it.

When you make your mains electrical supply cable, ensure that the earth (ground) conductor is longer than the live and neutral conductors. This will ensure that if the cable is accidentally dragged and the strain relief on the cable-gland fails, the earth (ground) conductor will be the last conductor to be pulled from the analyser.

Connect your mains electrical supply cable to the analyser as follows:

- Refer to Figure 4. Connect the wires in the supply cable to the appropriate electrical supply terminals P101, as follows:

Signal	Terminal pin
Live	P101 L
Neutral	P101 N
Protective Earth (ground)	P101



The analyser must be connected to an external protective earthing system, using the Protective Earth on terminal P101.



*L'analyseur doit être raccordé à un système de terre de protection externe via la terre de protection sur la borne P101.*

**Note:** It is recommended that the 1/2 inch NPT cable entry hole on the far right hand side of the enclosure is used for the power supply cable.

## 5.4 Refit the power/interface compartment cover



The power/interface compartment cover is heavy. Ensure that you do not drop the cover when you refit it to the body of the analyser. If you do, you may injure yourself or damage other equipment.



*Le couvercle du compartiment alimentation/interface est lourd. Veillez à ne pas le faire tomber en tentant de le revisser sur le corps de l'analyseur.  
Vous risqueriez de vous blesser et d'endommager les autres équipements.*



Ensure that the pregreased threads of the cover do not become contaminated.

**Note:** *The threads on the cover are pregreased. You do not need to add any grease or sealant to the threads before you refit the cover.*

1. Tighten the strain relief on all of the cable-glands fitted to the base of the analyser.
2. Refer to Figure 1. Carefully refit the cover to the body of the analyser, so that the threads on the rear of the cover are correctly aligned with the threads in the analyser: pick the cover up by its exterior, and do not touch or contaminate the pregreased threads on the cover.
3. Screw on the cover (that is, turn the cover clockwise) to secure it to the analyser.

**Note:** *It can help to turn the cover anticlockwise, up to one turn, till you feel or hear the threads align, before beginning to screw on the cover clockwise.*

4. Fully tighten the cover. If necessary, fit a suitable metal bar between the protruding fins on the front of the cover to provide additional leverage.
5. Use the 2 mm hexagonal key supplied to tighten the locking screw which secures the cover.
6. Ensure that the certification label is in the correct orientation. If necessary, press and turn the label until it is in the correct orientation.

## 5.5 External earth (ground) connection



When the analyser is installed in a hazardous area, the analysers' external earth (ground) connection located on the base of the analyser, Figure 2 or Figure 3, must be equipotentially bonded locally to the analyser. You must correctly connect it in compliance with all relevant local, national and international standards, to ensure

that the installation is safe. Failure to do so will invalidate the hazardous area certification.



*Dans le cas d'une installation en zone dangereuse, la connexion de terre externe située à la base de l'analyseur (Figure 2 ou Figure 3) doit être reliée localement de façon équipotentielle à l'analyseur. Vous devez la raccorder en conformité à toutes les normes locales, nationales et internationales afin d'assurer la sécurité de l'installation. Le non-respect de cette obligation invalide la certification d'agrément pour zones dangereuses.*



To comply with the EMC emissions and susceptibility standards, the external earth (ground) connection is also considered to be a Functional Earth and must always be connected to a local EMC earth (ground). The conductor that you use must not exceed 2 metres in length.

Use a suitable conductor to connect the analyser external earth (ground) terminal to a local equipotential earth (ground) point: see warning and caution above. You can use flexible or solid conductors, up to 10 mm<sup>2</sup> up to a maximum length of 2 metres.

## 5.6 Connect the sample/calibration gas pipe(s)



Ensure that the pipes that you connect to the analyser are routed so that they do not present a trip hazard to people.



*Les flexibles connectés à l'analyseur doivent être disposés de sorte qu'ils ne risquent pas de faire trébucher le personnel.*



Sample and calibration gases may be toxic, asphyxiant or flammable. Ensure that the external connections are leak free at full operating pressure before you use sample or calibration gases.



*Les gaz échantillon et de calibrage peuvent être toxiques, asphyxiants ou inflammables. Avant d'utiliser les gaz échantillon ou les gaz de calibrage, assurez-vous que les raccords externes ne présentent pas de fuites à la pression maximum de fonctionnement.*



Sample and calibration gases may be toxic, asphyxiant or flammable. Ensure that the sample outlet pipe is vented to an area where the gases will not be a hazard to people.



*Les gaz échantillon et de calibration peuvent être toxiques, asphyxiants ou inflammables. Le tuyau d'évacuation de l'échantillon doit être mis à l'évent vers un endroit où le gaz ne présentera aucun risque pour les personnes.*



Sample and calibration gases may be toxic, asphyxiant or flammable. To prevent the build-up of such gases, ensure that the analyser is used in a sufficiently well-ventilated environment.



*Les gaz échantillon et de calibration peuvent être toxiques, asphyxiants ou inflammables. Pour éviter l'accumulation de tels gaz, l'analyseur ne doit être utilisé que dans un milieu bien aéré.*



When you carry out a leak test, do not exceed a maximum pressure of 34.5 kPa gauge (0.35 bar gauge, 5 psig) and do not introduce a sudden change of pressure into the analyser. If you do, you can damage it.



If you use a liquid to assist in leak testing, do not spill liquid onto any of the electrical components in the sample/control compartment.



If optional sample compartment heating is fitted the maximum gas dew point is 50°C. To prevent condensation reaching the analyser the gas should be maintained at a minimum of 55°C up to the inlet connection. Sample compartment heating is not designed to be a replacement for other sample conditioning systems used for high dew point gases.

Connect your sample/calibration gas inlet and outlet pipes to the sample gas inlet and outlet on the base of the analyser (see Figure 2). The inlet/outlet fittings on the analyser are 1/4 inch NPT female.

Refer to Section 2.4 for the sample gas requirements, and refer to Section 2.6 for the calibration gas requirements

Locate your gas selection valves (to direct sample or calibration gas into the analyser) as close as possible to the analyser.

**Note:** *Do not introduce calibration or sample gases into the analyser yet. You must switch on the electrical supply and leave the analyser for at least 4 hours before you allow calibration or sample gases into the analyser. Refer to the Caution at the start of Section 6.*

## 5.7 Switch on/set-up

**Note:** When the electrical supply to the analyser is switched on, the Alarm LED and the Fault LED will both go on for 1 second to demonstrate that they are functioning correctly, and will then go off again.

When you switch on the electrical supply to the analyser, a 'start-up screen' is first displayed, then the Measurement screen (Figure 6) is displayed.

## 5.8 Selecting the security level and password(s)

You can configure the analyser to provide any of three levels of security:

Security level	Function
Low	None of the options/screens are password protected *.
Standard	Some of the options/screens are protected by a supervisor password.
High	Some of the options/screens are protected by a supervisor password and some of the options/screens are protected by an operator password †.

\* Except for the 'change the password(s)' and 'select the security level' options/screens: see notes below.

† The supervisor password can also be used to access options/screens protected by the operator password: see notes below.

**Note:** The 'change the password(s)' and 'select the security level' screens/options are always protected by the supervisor password, regardless of the security level selected. This is to ensure that unauthorised personnel cannot change the security level and password(s) and so lock out the analyser from other users.

**Note:** The supervisor password provides access to all password protected options/ screens. That is, if you have selected the 'high' security level and are prompted to enter the operator password, you can also access the option/ screen by entering the supervisor password.

**Note:** Password protection can be used to prevent adjustment of the clock by unauthorised persons, so ensuring the validity of measurement times and the 'time since last calibration' history.

Figure 7 shows the options/screens which can be password-protected within the menu structure.



## 5.9 Setting the security level

**Note:** As supplied, the security level is set to 'high', the supervisor password is set to "2000" and the operator password is set to "1000".

Before the analyser is used for sample measurement, we recommend that you select the security level most suitable for the way in which the analyser will be used by you and/or your personnel.

Use the following procedure to select the required security level:





1. Select  → Settings → Security.
2. To change the security level, press the  soft key. You will then be prompted to enter the supervisor password.
3. Once the supervisor password has been entered correctly, the Security select screen will be displayed (see Figure 15), with the currently selected security level highlighted.
4. To change the security level, use the  and  soft keys to highlight the required level, then press the  soft key. The Security level screen will then be displayed again, showing the newly selected security level.



Figure 15 - The Security level screen



Figure 16 - The Security select screen

## 5.10 Changing passwords

**Note:** If you change a password, ensure that you record the new password somewhere safe. Otherwise, if you cannot recall the new password, you will have to contact Servomex or your local Servomex agent for assistance.

Use the following procedure to change the supervisor and operator passwords:





1. Select:  → Settings → Password.
2. To change the supervisor password, press the  soft key, then enter the new password.
3. To change the operator password, press the  soft key to display the edit operator password screen, press the  soft key, then enter the new password.



Figure 17 - The Edit supervisor password screen

## 5.11 Adjusting the contrast

1. Select: → Settings → Contrast
2. Use the and soft keys to increase or decrease the contrast to the required level, then press the soft key.



Figure 18 - The Contrast screen

**Note:** Hold the or soft key pressed in to adjust the contrast quickly.

## 5.12 Adjusting the backlight timer

When the analyser is first switched on, the backlight goes on to illuminate the screen. If no soft key is pressed, the backlight will remain on for the pre-set 'backlight time', and will then go off. The timer associated with the backlight time is restarted whenever a soft key is pressed (that is, the backlight remains on for the backlight time after the last soft key press). To adjust the backlight time:

1. Select: → Settings → Backlight
2. Change the backlight time (Duration) setting as required, then press the soft key.



Figure 19 - The Backlight timer screen

**Note:** The backlight time (Duration) can be set between 0 and 999 seconds. Set the backlight time (Duration) to 0 seconds to leave the backlight permanently switched on.

## 5.13 Setting the clock

**Note:** The time and date will remain set for approximately 1 week if the power supply to the analyser is switched off.

Use the following procedure to set the date and time:

1. Select:  → Settings → Clock
2. Edit the displayed time.



Figure 20 - The Clock (time) screen

3. Edit the displayed date.
4. The date format can be set to your regional preference ('day/ month/year' or 'month/day/ year'): refer to Section 5.14.

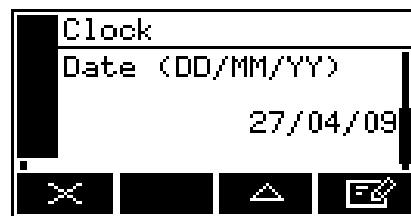

Figure 21 - The Clock (date) screen

## 5.14 Changing regional settings

You can configure the following analyser regional settings so that the information shown on the various screens is better suited to your local conventions:

Setting	Options available
Language	Various languages are supported
Date format	Day/Month/Year * or Month/Day/Year
Decimal format	Use of "."* (full stop) or "," (comma) as the decimal point

\* Default option.

To change the regional settings:

1. Select:  → Settings → Regional
2. This screen shows the first regional option (Language).



Figure 22 - The Regional settings (Language) option screen

## 5.15 Setting up automatic validation/calibration (option)

### 5.15.1 Overview of automatic validation/calibration

Automatic validation operates in the same way as automatic calibration, except that the transducer is not calibrated when the low and high calibration gases have been passed through the transducer. Automatic validation therefore allows you to determine the drift of sample measurements over time. You can set tolerance levels, so that if the sample measurements fall outside acceptable limits, a 'maintenance required' status is raised (🔧) to identify that a full calibration needs to be carried out.

If your analyser supports auto validation/calibration you have the option to:

- Configure the analyser so that automatic validation/calibration of a transducer is carried out once (at a pre-set time).
- Configure the analyser so that automatic validation/calibration of a transducer is carried out repeatedly at a specified frequency.
- Use the soft keys to manually start an automatic Validation/Calibration
- Use a control input signal (on the RS485, Ethernet or digital input) to initiate an automatic validation/calibration.

**Note:** You can also perform a 'remote calibration' using the switched inputs on the calibration option PCB if they are configured accordingly.

Automatic validation/calibration provides the following functionality:

- During an automatic validation/calibration of a transducer, the analyser controls gas selection relays which can be used to control the flow of low and high calibration gases into the analyser.
- The analyser checks that the resulting measurement is within the pre-set validate target range (validate target value  $\pm$  validate tolerance value).
- If the measurement is within the pre-set validate target range and mode is set to calibrate, the transducer is calibrated (as in manual calibration).
- You can specify a pre-warning time, which will precede the automatic validation/calibration. During this time, the 'service in progress' status output will be set; the automatic validation/calibration will then be carried out at the end of the pre-warning time. If automatic validation is cancelled during this time the gas selection control will not have changed state.
- You can specify an inerting phase. This ensures that non-inert hazardous mixtures of calibration gas and sample gas cannot flow into the analyser one immediately after the

other. During this phase, inert gas (the low or high calibration gas) will be introduced between the two gases for a pre-set time.

- You can specify a flushing phase. This phase operates as a delay, after a different gas is routed into the analyser, before a validation/calibration is carried out.

### 5.15.2 Automatic validation/calibration sequence

Before you carry out an automatic validation/calibration, you must pre-set the following parameters:

Parameter	Use/range
Low target value	Low measurement target value for validate/ calibrate.
Low target tolerance	Low measurement target tolerance.
High target value	High measurement target value for validate/ calibrate.
High target tolerance	High measurement target tolerance.
Validation/Calibration type	Low, High, Low & High or High & Low.
Mode	Calibration or Validation.
Pre-warning	On or Off.
Pre-warning time	Only applicable if Pre-warning is On. Specifies the length of the pre-warning period (0 min 1 sec to 59 min 59 sec).
Inerting	On or Off.
Inert gas	Only applicable if Inerting is On. Specifies the type of inert gas (High or Low).
Inerting time	Only applicable if Inerting is active. Specifies the inerting time (0 min 30 sec to 59 min 59 sec).
Flushing time	Specifies the flushing time (0 min 30 sec to 59 min 59 sec).
Timer	On (active) or Off (inactive). If active the calibration or validation can be carried out regularly at a specified frequency.
Start time/date	Only applicable if the timer is active. This specifies the time/date on which the first automatic validation/calibration will be carried out.
Repeat time	Only applicable if the timer is active. If set (in the range 1 hour to 999 days), specifies the interval between successive automatic calibrations/ validations. Select 0 hours and 0 days if repeat is not required.

Figure 23 shows a typical automatic calibration sequence, where:

- Pre-warning is on.
- Automatic calibration has been initiated.
- Validation/Calibration type has been set to Low & High.
- Mode has been set to Calibration.
- Inerting is set to On (active) and Inert gas has been set to Low Calibration Gas.

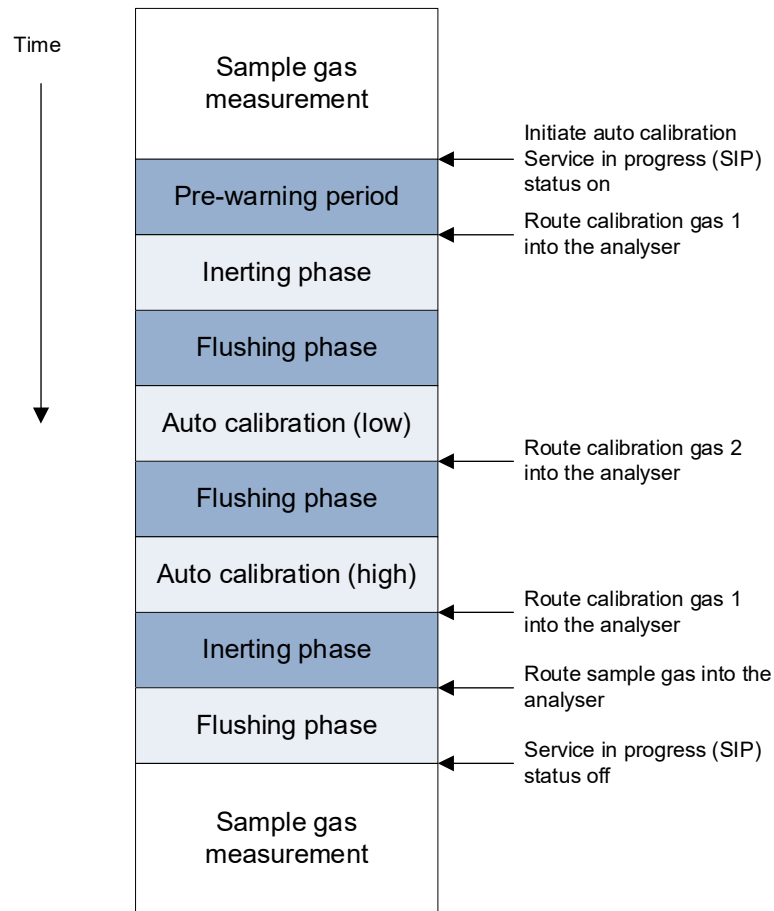

**Figure 23 - Typical automatic calibration sequence**

### 5.15.3 Remote calibration or automatic validation/calibration

Switch inputs can be set to remote calibration mode (Remote cal), automatic validation/calibration mode (Auto val) or disabled so the inputs will have no function.



In Remote cal mode, switch input pins P108 1 and 2 activate a transducer low calibration (as if the request had been selected from the user interface) and switch input pins P108 3 and 4 activate a transducer high calibration. Switch input pins P108 5 and 6 activate the transducer service in progress (SIP) status, which must be closed before either calibration can be executed. This is to ensure a calibration cannot be executed without a service in progress status being activated. For example, to carry out a remote low calibration:

- Close pins 5-6** Remote service in progress (SIP) on (latching switch)
- Close pins 1-2** Activate low calibration (momentary switch)
- Open pins 5-6** Remote service in progress (SIP) off

A calibration will be successfully completed if the current measurement is equal to the target measurement +/- the auto validation tolerance values, See Figure 26. If this condition is not met a Maintenance required status will be raised.

**Note:** If the switch inputs are set to 'Remote Cal' mode the gas control relays will not be changed from 'sample' during a remote low or high calibration.

See Section 6 for instructions on Manual Calibration to ensure that your calibration procedure is correctly configured.

1. In Auto val mode, switch input pins 1-2 Initiate an Auto Validation/Calibration sequence and switch input pins 3-4 stop an Auto Validation/Calibration sequence. Select  → Set up → Switch Inputs.
2. Use to  soft key to select either Auto val, Remote cal or Disabled.

#### 5.15.4 Automatic validation/calibration target and tolerance

1. Select:  → Settings → Auto val
2. Select Target, the Auto val/cal low target value screen will then be displayed.



Figure 24 - The Auto val/cal parameters screen

3. Edit the displayed low target value.



Figure 25 - The Auto val/cal low target value screen

4. Edit the low tolerance value.

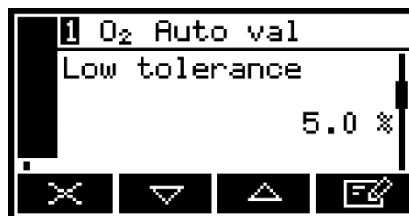

Figure 26 - The Auto val/cal low tolerance screen

5. Scroll down to the High target value then repeat steps 3 and 4 to set the High target and High tolerance values.





Figure 27 - The Auto val/cal high target value screen

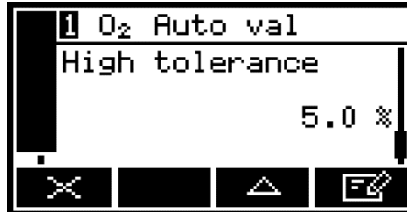

Figure 28 - The Auto val/cal high tolerance screen

### 5.15.5 Automatic validation/calibration type and mode

1. Return to the Auto val screen (Figure 24) Select 'Control'.
2. Select required type: 'Low', 'High', 'Low & High', 'High & Low'.



Figure 29 - The Auto val/cal type screen

3. Select 'Mode'. Select required type: 'Validate' or 'Calibrate'.



Figure 30 - The Auto val/cal mode screen

### 5.15.6 Automatic validation/calibration phases

1. Return to the Auto val screen (Figure 24). Select 'Phase'.
2. Select 'On' or 'Off' for Pre warning.



**Figure 31 -The Auto val/cal phase screen**

3. If you changed the pre-warning setting from 'Off' to 'On', the Auto val/cal pre-warning timer screen will then be displayed (see Figure 32). Edit the displayed time.

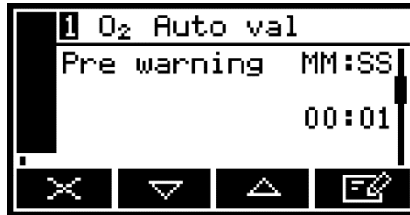

**Figure 32 - The Auto val/cal pre- warning timer screen**

4. Select 'On' or 'Off' for Inerting.



**Figure 33 - The Auto val/cal inerting screen**

5. If you have changed the Inerting setting from 'On' to 'Off', continue at Step 9, otherwise continue from step 6.
6. Select the correct inert gas: 'Low' or 'High'.



**Figure 34 - The Auto val/cal inert gas screen**

7. Scroll to the Auto val/cal inerting timer screen, showing the currently selected inerting time setting.
8. Edit the time.



**Figure 35 - The Auto val/cal inerting timer screen**

9. Scroll to the Auto val/cal flushing screen, showing the currently selected flushing time setting.
10. Edit the time.



**Figure 36 - The Auto val/cal flushing screen**

#### **5.15.7 Automatic validation/calibration timers**

1. Return to the Auto val screen (Figure 24). Select 'Timer'.
2. Select 'On' or 'Off' for Timer.



**Figure 37 - The Auto val/cal timer screen**

3. Scroll to the Auto val/cal start date screen.
4. Edit the displayed start date.



**Figure 38 - The Auto val/cal start date screen**

5. Scroll to the Auto val/cal start time screen.
6. Edit the displayed start time.



**Figure 39 - The Auto val/cal start time screen**

7. Scroll to the Auto val/cal repeat time screen.
8. Edit the displayed repeat time.



**Figure 40 - The Auto val/cal repeat time screen**

**Note:** If you set the repeat time to "000:00" (0 days, 0 hours), the automatic validation/calibration will only be performed once, on the specified start date, at the specified start time. You will therefore need to initiate any subsequent automatic validation/calibration: see Section 6.2.1.

## 5.16 Configuring and using the mA outputs

### 5.16.1 Overview

The milliamp output provides a constantly updated output, in which the current represents the value of gas sample measurement.

The analyser allows you to specify two separate range configurations for the milliamp output: Range 1 and Range 2. The current range is shown on the Measurement screen (see Figure 6):

I is shown if Range 1 is selected.

II is shown if Range 2 is selected.

The mA output can be selected as:

- 0 to 20 mA, where 0 mA represents the lowest sample measurement and 20 mA represents the highest sample measurement in the range you have specified.
- 4 to 20 mA, where 4 mA represents the lowest sample measurement and 20 mA represents the highest sample measurement in the range you have specified.

In addition to the above, you can specify how the milliamp output will operate during calibration, during a fault condition, and during under range conditions.

### 5.16.2 Introduction to the mA output parameters



For safety critical applications or applications where the fault relay is not being utilised, the mA output should be configured to 4-20mA and Jam Low (Default Settings). This will prevent analyser faults remaining undiagnosed and is the safest mode of operation.



*Pour les applications où la sécurité est primordiale ou celles où le relais d'erreur n'est pas utilisé, la sortie mA doit être réglée sur 4-20 mA et sur Bloc Bs (paramètres par défaut). Vous assurez ainsi que toutes les erreurs de l'analyseur seront diagnostiquées, ce qui représente le mode de fonctionnement le plus sûr.*

The milliamp output parameters that you must set up are as follows:

Parameter	Values/options
Range	The selected option determines the mA output range associated with a measurement: <ul style="list-style-type: none"> <li>Range 1 The output is set to use range 1.</li> <li>Range 2 The output is set to use range 2.</li> <li>Auto The output will automatically switch between Range 1 and Range 2 depending on sample measurements.</li> </ul>
Range 1 low level	The Range 1 lowest sample measurement.
Range 1 high level	The Range 1 highest sample measurement (span).
Range 2 low level	The Range 2 lowest sample measurement.
Range 2 high level	The Range 2 highest sample measurement (span).
During calibration	The selected option determines how the mA output will operate during calibration: <p>As soon as the calibration screen is displayed, the milliamp output will 'freeze' at its last output value. The output will only be updated to reflect subsequent measurements when the calibration screen has been exited.</p> <ul style="list-style-type: none"> <li>Freeze The milliamp output value will reflect the measurement value, even during calibration.</li> <li>Follow</li> </ul>
Jam condition	The selected option determines how the mA output will operate during a fault condition: <ul style="list-style-type: none"> <li>High The output value will be held at 21.5 mA.</li> <li>Low* The output value will be held at 0 mA.</li> <li>None The output values will continue to be derived from the sample gas measurements, even though these output values may be erroneous.</li> </ul>
mA output range	0-20 mA or 4-20 mA. *
Under range	Any value below 4 mA. #
Range change point	The range change point. †
Hysteresis	The range change hysteresis. †
†	Only available when Auto range is selected.
*	Default setting. Fail safe operation.

# Only available if the 4-20mA output range is selected; this sets the lowest output current during normal operation, and allows negative gas concentrations to be monitored through the mA output. For example, with an under-range setting of 3.8 mA, the mA output can be less than 4 mA (which indicates a zero gas concentration), down to a minimum of 3.8 mA, where an output between 3.8 mA and 4 mA indicates a negative gas concentration.

### 5.16.3 Setting up the mA output parameters

**Note:** *If Auto ranging is selected, the way in which the output changes between the ranges depends on the values you have set for the range change point and the hysteresis.*

*For example, if you set the range change point to 18% and set hysteresis to 1%, then: The output value must be greater than 18% before changing from Range 1 to Range 2. The output value must be less than 18% - 1% (17%) before changing from Range 2 to Range 1.*

Use the following procedure to select Auto Ranging or manually select the range:

1. Select:  → Settings → mA output
2. Select the Range option.

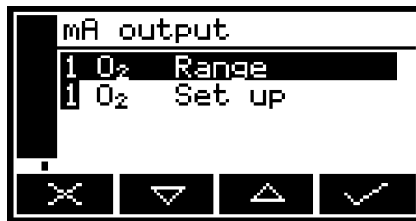

Figure 41 - The mA configuration screen

3. Select the Range option you want the output to use (Range 1, Range 2 or Auto). If you have selected Auto ranging, you must also set the range change and hysteresis values.

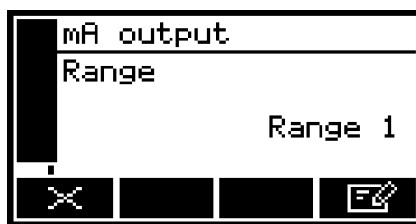
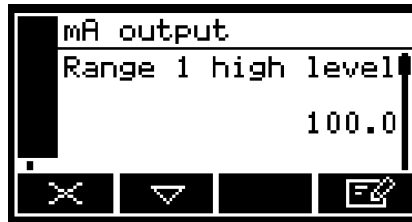

Figure 42 - The mA range screen

4. Return to the mA configuration screen (Figure 41) and select 'Set up' option.
5. Edit the Range high level and low level.



**Figure 43 - The mA output high level screen**

6. You can select the during calibration option to 'Freeze' or 'Follow'



**Figure 44 - The during calibration screen**

7. You can then select the Jam condition to 'High', 'Low' or 'None'

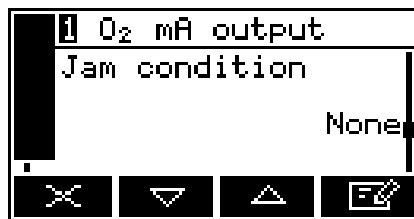

**Figure 45 - The jam condition screen**

8. You can then select the range that you would like to use: 0-20mA or 4- 20mA.

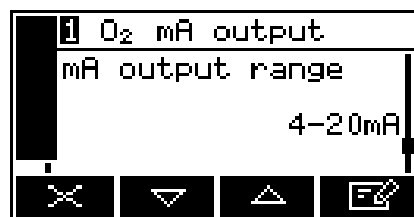

**Figure 46 - The mA output range screen**

9. You can then select the under range value.



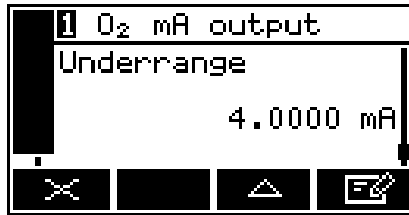

Figure 47 - The mA under range screen

10. If Auto Ranging is selected you will then need to set the Range change point and the Hysteresis.

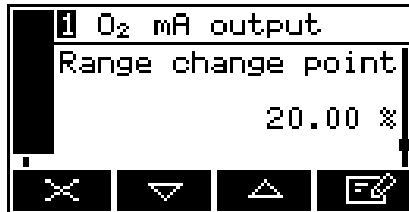

Figure 48 - The mA range change point screen.

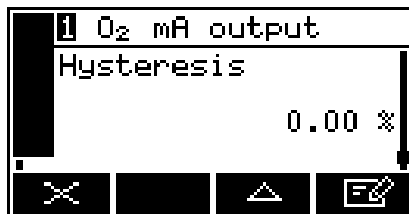

Figure 49 - The mA range change hysteresis screen

#### 5.16.4 Calibrating the mA output

Use the following procedure to calibrate the mA output:

1. Select:  → Service → mA output
2. Select the required 'Calibrate' option.

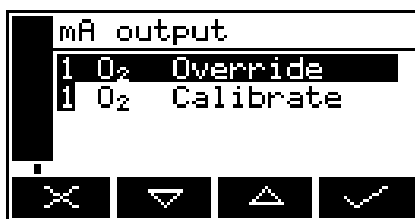

Figure 50 - The mA output service screen

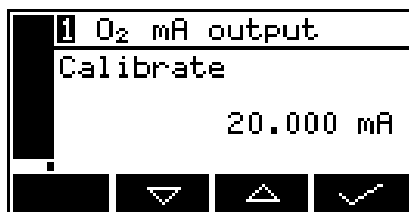





Figure 51 - The mA output calibrate screen

3. As soon as the mA output calibrate screen is shown, the nominal mA output value is set to 20 mA:
  - Use your control/monitoring equipment (connected to the analyser) to monitor the actual output value.
  - Use the  and  soft keys to increase or decrease the actual output value until your control/monitoring equipment indicates 20 mA output.
4. When the mA output has been correctly calibrated, press the  soft key: the mA output service screen (Figure 50) will then be displayed again.

**Note:** *The actual mA output value is controlled from the mA output calibrate screen as long as the screen is displayed. As soon as the mA service screen is no longer displayed, the mA output value will be updated to reflect the corresponding gas measurement.*

## 5.17 Configuring and using the relay outputs

### 5.17.1 Overview relay default status settings

As **default** the relays are set up as in the following table. For details on relay connections refer to Section 5.3.3.

Relay	Relay coil state in "active" status	Definition of "active" status
Fault	Deenergised	Measurement or analyser fault detected
Alarm 1	Energised	Alarm 1 active
Alarm 2	Energised	Alarm 2 active
mA Range Indication	Energised	mA range has changed over from range 1 to range 2
Service in Progress (SIP)	Energised	Service in progress status enabled
Maintenance Required	Energised	Measurement or analyser maintenance required detected

The relay coil status, energised or deenergised, can be set up to meet any particular application requirements.

**Note:** Example:

*As default, the fault relay coil is deenergised during an "active" status. As defined above, this is when a measurement or analyser fault is detected.*

*Therefore if the power to the analyser fails or the relay cable is disconnected, then this is transmitted as a fault, as electrically it has the same effect as if the fault relay is deenergised, this is often termed "fail safe".*

*In some applications it is preferred that the fault relay is energised in an "active" status, if this is the case then the relay coil set up can be changed as detailed in Section 5.17.2.*

### 5.17.2 Setting up the relay coil status

To define the "active" status of the relay coil, see Section 5.17.1

1. Select:  → Set Up → Relay Set Up
2. Edit fault relay coil state that is required for the "active" status

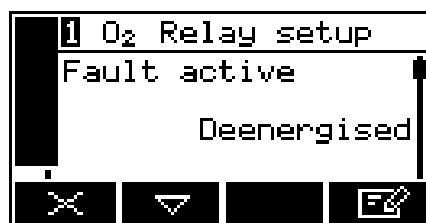

**Figure 52 - Fault Relay**

3. Edit Maintenance Required relay coil state that is required for the "active" status

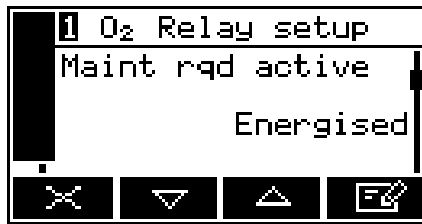

**Figure 53 - Maintenance Required**

4. Edit Service in Progress (SIP) relay coil state that is required for the "active" status

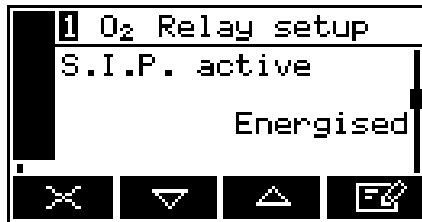

**Figure 54 - Service in Progress**

5. Edit Alarm 1 relay coil state that is required for the "active" status

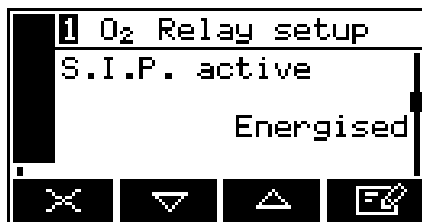

**Figure 55 - Alarm 1**

6. Edit Alarm 2 relay coil state that is required for the "active" status

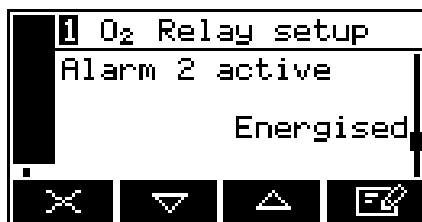

**Figure 56 - Alarm 2**

7. Edit mA Range Indication relay coil state that is required for the "active" status



Figure 57 - mA Range Indication

## 5.18 Correcting O<sub>2</sub> measurements for background gases

**Note:** *If you are measuring O<sub>2</sub> (oxygen) in a background of nitrogen or air, you do not need to correct the measurements.*

### 5.18.1 Overview of measurement errors

For a paramagnetic oxygen measurement, the composition of any typical background gas in the gas sample will have a minor effect on the analyser measurement. For an analyser which has been 'Lo' calibrated with N<sub>2</sub> (nitrogen) and 'Hi' calibrated with O<sub>2</sub>, some examples of cross-interference errors (that is, O<sub>2</sub> measurement errors) in gases

which contain 100% of a background gas are shown below. See Appendix D for more corrections.

Background gas	Error	Background gas	Error
Hydrogen	0.26%	Methane	-0.18%
Carbon dioxide	-0.30%	Propane	-0.87%

**Note:** *The error is directly proportional to the concentration of the background gas in the sample being measured, and in many cases can be ignored.*

**Note:** *All corrections must be calculated using 60°C data from the tables in Appendix D.*

If you cannot ignore the error, you can use the procedure in Section 5.18.2 to enter a compensation to correct for the error. Example corrections are shown below.

**Note:** *Example:  
If you are measuring O<sub>2</sub> (oxygen) in a background of Carbon dioxide -0.30 should be entered as the cross interference offset.*

**Note:** Example:  
If you are measuring 10% Oxygen in a background of 70% Hydrogen and 20% Carbon Dioxide the correction factor would be:

The correction factor assumes 100% of background gas, so you must firstly correct for the nominal process oxygen concentration:

Total background concentration = 70% + 20% = 90% Correct background concentrations for 0% oxygen:

$(100\% / 90\%) \times 70\% = 77.8\%$  Hydrogen  
 $(100\% / 90\%) \times 20\% = 22.2\%$  Carbon Dioxide

For 100% Hydrogen the correction is 0.26, so for 77.8% it is 0.202

For 100% Carbon Dioxide the correction is -0.30, so for 22.2% it is -0.067

So the total correction factor in this case is  $-0.067 + 0.202 = 0.135$

### 5.18.2 Entering a cross-interference compensation

**Note:** Cross-interference compensation is disabled during calibration, and is not applied to the values shown in Figure 75. All other outputs (that is, serial or mA outputs) remain compensated.

Use the following procedure to enter a compensation to correct for an O<sub>2</sub> (oxygen) measurement error:

1. Select:  → Set Up → Interference
2. The offset value shown on the X- Interference offset screen is the correction which will be applied to O<sub>2</sub> (oxygen) sample measurements before they are displayed (or output).
3. Edit the displayed offset.

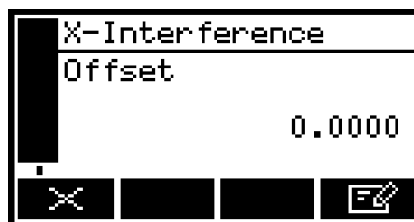

Figure 58 - The X-Interference offset screen

### 5.19 Selecting display units

You can change the measurement units shown on the display (and output). The following display units are supported:



Units	Meaning
%	volume %
ppm	parts per million
vpm	volume parts per million
mg/m <sup>3</sup>	mg m <sup>-3</sup> (milligrams per normal cubic metre)
mol/mol	mols per mol (or moles per mole)
% LEL	volume % of the Lower Explosive Limit

**Note:** When you select display units other than the measurement default units, you must also enter the units conversion factor: refer to Appendix C to determine the units conversion factor for your specific application.

**Note:** If you select the "off" option on the units selection screen, the display units revert to the measurement default units as supplied.

**Note:** Converting from one measurement unit to a different display measurement unit may reduce the resolution of the displayed measurements.

Use the following procedure to select the displayed units, and to change the units conversion factor:

1. Select:  → Set Up → Unit selection
2. If you want to change the currently displayed units, press the  soft key: the Units selection screen will then be displayed.

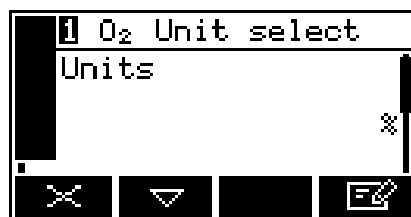

**Figure 59 - The Currently selected units screen**

3. If required scroll to the "Factor" screen to change the unit conversion factor.

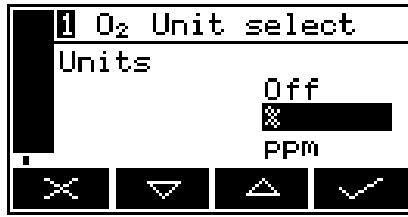

Figure 60 - The Units selection screen

4. Edit the displayed offset referring to Appendix C for the correct value.

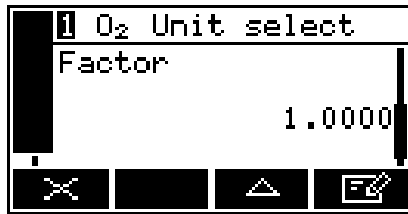

Figure 61 - The Units conversion factor screen

## 5.20 Configuring the measurement alarms

### 5.20.1 Alarm modes and levels

Two separate measurement alarms are available for the gas measurement and you can configure each alarm to operate in one of three modes:

Alarm mode	Operation
None	The alarm is not used (that is, an alarm condition will not be activated under any circumstances).
Low alarm	An alarm condition will be activated when a sample measurement is lower than the pre-set alarm level. *
High alarm	An alarm condition will be activated when a sample measurement is higher than the pre-set alarm level. *

\* During a calibration, an alarm will only be activated if the alarm 'Follow' option is set to Yes.

While a measurement alarm condition is activated:

- An 'alarm' icon is shown on the measurement screen. The number ("1" or "2") in the icon will identify the alarm which has been triggered.
- The alarm LED on the front of the analyser flashes on and off.
- The appropriate alarm relay will be triggered. You can view the details of the activated alarm: see Section 5.20.4.

**Note:** Ensure that the measurement alarm and hysteresis levels are not too close to the expected sample measurements. (If there are minor and acceptable variations in your sample gas concentrations this will reduce spurious alarms).



**Note:** *If you configure one measurement alarm as 'low' and configure the other alarm as 'high', ensure that the 'high' alarm and hysteresis levels are higher than the 'low' alarm and hysteresis levels. (If you do not, the analyser can be permanently in an alarm condition, until you correct the levels).*

1. Select  → Set up.
2. Select the required transducer and alarm.

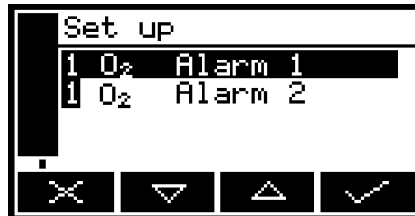

**Figure 62 - The Alarm set up screen**

3. Select the required mode (none, low or high), then press the  soft key.



**Figure 63 - The Alarm mode screen**

4. Scroll up or down to edit the appropriate settings:
  - Latching (Section 5.20.2)
  - Level
  - Hysteresis (Section 5.20.3).

**'Follow' option:**

- If the 'Follow' option is set to 'No', the alarm will be inhibited during calibration.
- If the 'Follow' option is set to 'Yes', the alarm will not be inhibited during cal.

1. Select  → Set up.
2. Select the required alarm.

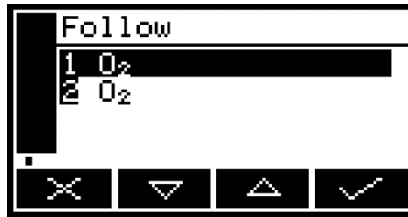

Figure 64 - The Alarm follow screen

3. Select the correct option: 'Yes' or 'No'.

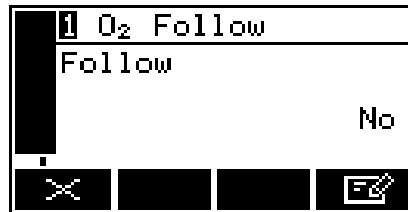



Figure 65 - The Alarm follow options screen

### 5.20.2 Latching/non-latching alarms

You can configure each of the two measurement alarms to be either latching or not latching:

Alarm setting	Meaning
Latching	Once the alarm condition has been activated, the alarm condition remains activated (even if subsequent sample measurements would not trigger the alarm) until the alarm is manually unlatched.
Not latching	Once the alarm condition has been activated, the alarm condition remains activated only until a subsequent sample measurement which would not trigger the alarm is made. The alarm condition is then deactivated.

When necessary, use the following procedure to unlatch any 'latched' measurement alarm(s):

1. On the Measurement screen, press the  soft key; the Alarm option screen (Figure 62) will then be displayed.
2. With the "Unlatch" option highlighted, press the  soft key. All latched alarms will then be unlatched and the Measurement screen will be displayed again.

### 5.20.3 Hysteresis levels

The hysteresis level associated with a measurement alarm determines when an alarm condition (once activated) is deactivated, and this depends on the alarm mode, as follows:

Alarm mode	Effect of hysteresis
Low alarm	Once the low alarm condition has been activated, the alarm condition will not be deactivated until a sample measurement is above (alarm level + hysteresis level).
High alarm	Once the high alarm condition has been activated, the alarm condition will not be deactivated until a sample measurement is below (alarm level - hysteresis level).

For example:

- If a 'low' alarm has an alarm level of 18% and a hysteresis level of 1%, the alarm will be activated when a sample measurement is < 18%, and the alarm will not be deactivated until a sample measurement is > 19%.
- If a 'high' alarm has an alarm level of 20% and a hysteresis level of 2%, the alarm will be activated when a sample measurement is > 20%, and the alarm will not be deactivated until a sample measurement is < 18%.

#### 5.20.4 Viewing the measurement alarm status

1. Select  → View.
2. In the Alarm status screen shown in Figure 66, both measurement alarms are shown as "Inactive"; that is, either the mode of each alarm is set to 'none', or no alarm condition currently exists.

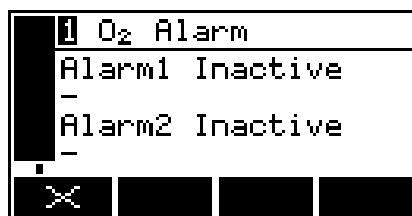

Figure 66 - The Alarm status screen

If a measurement alarm condition exists when you view this screen, the screen will show:

- The alarm number ("1" or "2").
- The sample reading which triggered the alarm condition.
- The alarm mode (where "<" indicates a low alarm and ">" indicates a high alarm).
- The alarm level.

#### 5.20.5 Setting the Measurement Filter Level

Use the following procedure to set up the measurement filtering:

1. Select:  → Set Up → Filtering
2. The current filter level is shown.



Figure 67 - Filter factor screen

3. Edit the filter factor to the desired level. Values must be between 001, no filtering, and 064.



Figure 68 - Filter Factor Edit Screen

**Note:** The value relates to the number of readings that the filter averages over. i.e. 15 would mean a filter length of 15 readings. The measurement reading updates five times per second, therefore in this case the filter length is three seconds of measurement data.

**Note:** It is only recommended that the filter level is altered, default value of 8 readings, if excessive measurement fluctuations are experienced. This could be caused by high levels of vibration or sample system fluctuations, and we recommend that the root causes of the fluctuations are fully investigated before applying higher filter levels, as increasing filter length increases the response time of the analyser i.e. at a filter length of 064 the response time (T90) of the analyser is approximately 19 seconds.

## 5.21 Setting up the Flowcube (F<sup>3</sup>) Flow Sensor (option)

The flow sensor option measures the sample flow through a measurement transducer and allows the user to configure two low flow alarms and one high flow alarm. The flow sensor allows preventative maintenance to be taken before the sample flow rate reduces to unacceptable levels Section 2.4.

Configuration options and defaults for each flow sensor alarm level are given below:

Alarm	Default Alarm Levels	Default Status	Configurable Alarm Levels	Status Options
Low flow alarm 1	70%	Maintenance required	25% to 90%	Maintenance required Fault None
Low flow alarm 2	50%	Fault	25% to 90%	
High flow alarm	130%	None	130%	

**Note:** A zero and normal calibration must be performed on the flow sensor before the reading is accurate. See Section 6.3 for the calibration procedure.

**Note:** To prevent false fault status indications during the change over of gases during measurement calibration or validation (not flow calibration) the status level of each flow alarm level will be demoted. A Fault status will be reported as a Maintenance Required and a maintenance required status will not be reported at all.

1. Select:  → Set Up → Flow alarm
2. Scroll to the low flow level 1 screen and set the activation level for low flow alarm 1.

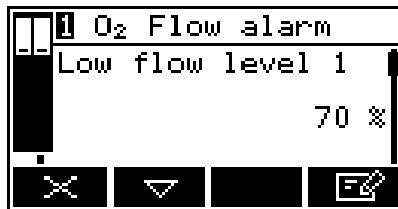

Figure 69 - The low flow level 1 screen

3. Scroll to the low flow level 2 screen and set the activation level for low flow alarm 2.

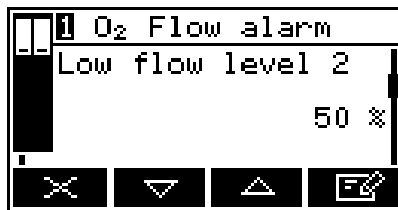
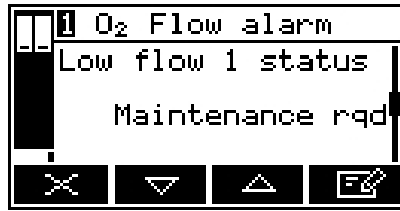

Figure 70 - The low flow level 2 screen

4. Scroll to the low flow 1 status screen and set the status type to be reported on low flow alarm 1 activation.



**Figure 71 - The low flow 1 status screen**

5. Scroll to the low flow 2 status screen and set the status type to be reported on low flow alarm 2 activation.

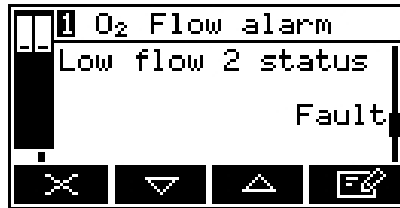

**Figure 72 - The low flow 2 status screen**

6. Scroll to the high flow status screen and set the status type to be reported on the high flow alarm activation (flow greater than 130%).

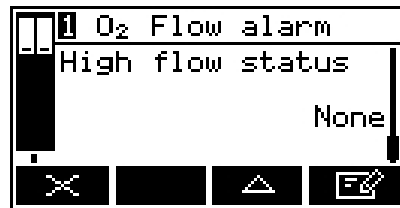

**Figure 73 - The high flow status screen**

## 6. CALIBRATION

---



Sample and calibration gases must be as specified in Sections 2.4 and 2.6. If the gas pressures and/or flow rates are above those specified in Sections 2.4 and 2.6, you must regulate the gases externally, before they enter the analyser.



You must leave the analyser (with the electrical supply switched on) for at least 4 hours before you allow sample or calibration gases into the analyser.

### 6.1 Manual calibration

**Note:** *The required frequency of calibration depends on the reliance that you place upon the accuracy and consistency of the measurements made by the analyser. Adjust the frequency according to your requirements/experience.*

**Note:** *You can carry out a manual calibration at any time unless an automatic validation/calibration is in progress.*

**Note:** *If the auto validation/calibration option is installed, the gas control relays (Section 5.3.4) will select the correct gas once the manual calibration screen is shown (Figure 74). Sample gas will be reselected once the screen is exited.*

**Note:** *For optimum measurement accuracy, perform Low **and** High calibrations.*

**Note:** *We recommend that you manually calibrate the analyser regularly during normal operation, and that you keep a record of the calibration errors. Use the errors to adjust the required calibration frequency*

You **must** manually calibrate the analyser as part of the initial set up, and whenever ambient conditions have changed.

If the analyser is configured for automatic validation/calibration (see Section 6.2).

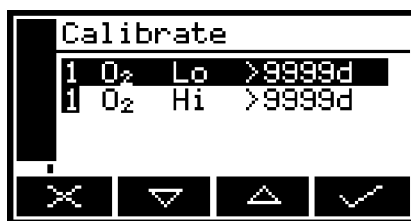

Manually calibrate the analyser as follows:

1. Ensure that your equipment is configured to correctly route your calibration gas supply to the analyser sample gas inlet.
2. Select  → Calibrate



**Figure 74 - The Calibrate screen**

Note that the "9999d" field of the screen shown in Figure 74 will identify the period of time that has elapsed since the last calibration, and can be in any of the following forms:

- 9999d specifying days
  - 9999h specifying hours
  - 9999m specifying minutes
  - Any combination of these.
3. Use the  and  soft keys to select the required calibration, that is:
    - 'Lo' (low calibration gas).
    - 'Hi' (high calibration gas).
  4. Press the  soft key. The Calibrate target value screen will then be shown, identifying the target value and the current reading.

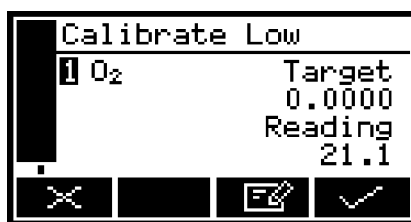

**Figure 75 - The Calibrate target value screen**

5. If the target value is not correct for the calibration gas which you are using, change the target value to the required value.

**Note:** Refer to Sections 2.4 and 2.6 for the required, flow rates and concentrations of the calibration gases.

6. When the current reading is stable, press the  soft key. The analyser will then carry out the specified calibration.
7. Repeat steps 3 to 6 of this section for the second calibration.

## 6.2 Automatic validation/calibration

### 6.2.1 Initiating an automatic validation/calibration



**Note:** You must have set up the parameters/options as described in Section 5.15.2 before you initiate an automatic validation/calibration.



**Note:** If the timer is active and you have set the repeat option, an automatic validation/calibration will be initiated automatically at the specified times.



**Note:** When an automatic validation/calibration is in progress, all new initiation requests will be ignored (that is, initiation requests are not queued).

Close the Start Auto val switch input on the appropriate interface connection (see Section 5.3.4) to initiate an automatic validation/calibration. Alternatively, you can manually initiate an automatic validation/calibration as follows:

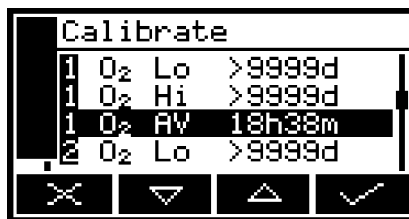
1. Press the  soft key on the Measurement screen (or select the "Calibrate" option from the Menu screen).
2. Use the  and  soft keys to select the required automatic validation/calibration.



**Figure 76 - The Auto val/cal select screen**

3. Press the  soft key.
4. Note that the date/time of the last automatic validation/calibration is shown on the screen. ("-") will be shown if no automatic validation/ calibration has previously been run).
5. Press the  soft key.

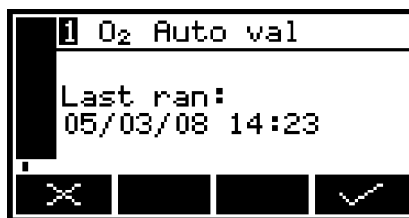

**Figure 77 - The Auto val/cal initiate screen**

6. Press the  soft key to initiate the automatic validation/calibration.

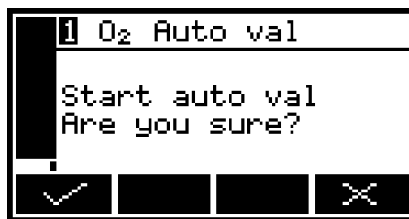

**Figure 78 - The Auto val/cal confirm screen**

## 6.2.2 Automatic validation/calibration status indications

During an automatic validation/calibration:

- A 'service in progress' icon (🔧) is shown on the measurement screen, if displayed.
- The calibration screen, if displayed, (pre-warning and inerting phase off) will be updated to show the current phase and the gas being used, as shown in Figure 79 to Figure 81.

**Note:** *If the automatic validation/calibration fails:*

*A 'maintenance required' icon (🔧) is shown on the measurement screen, if displayed.  
A "failed" message will be shown on the calibration screen (if displayed), for example:  
see Figure 82.*



Figure 79 - The Auto val/cal status screen (flushing phase)

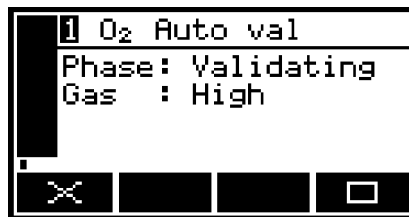

Figure 80 - The Auto val/cal status screen (validating phase)

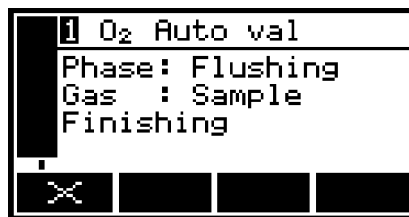

Figure 81 - The Auto val/cal status screen (finishing phase)

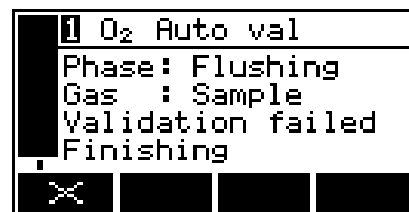





Figure 82 - The Auto val/cal failed screen

## 6.2.3 Stopping an automatic validation/calibration

**Note:** If you stop an automatic validation/calibration after the pre-warning phase, the inerting phase (if active) and the final flushing phase will always be completed.

To stop an automatic validation/calibration which is in progress, close the stop Auto val switch input on the appropriate interface connection (see Section 5.3.4) or use Modbus command see Appendix A. Alternatively, whenever an automatic validation/ calibration is in progress and the (  stop) icon is shown on the Auto val/cal status screen (see Figure 79 and Figure 80), you can press the  soft button to manually stop the automatic validation/calibration.

When you press the  soft button, the Auto val/cal stop confirmation screen is shown.

Press the  soft key to stop the automatic validation/calibration. The Measurement screen will then be displayed again.

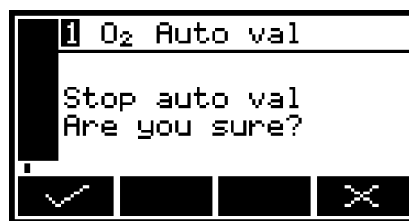



Figure 83 - The Auto val/cal stop confirmation screen

**Note:** Press the  soft key to continue with the automatic validation/calibration.

#### 6.2.4 Viewing validation/calibration history

You can use the following procedure to display the 100 most recent validation/ calibration points:

1. Select  → Calibrate → View history
2. This screen shows the target value (T) and the actual measurement reading (R) before val/cal was carried out.
3. It also shows whether the procedure performed was an Auto Calibration (Auto cal), Auto validation (Auto val), manual calibration (Man cal) and whether it was a Pass or a Fail.

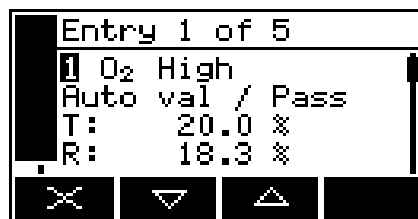
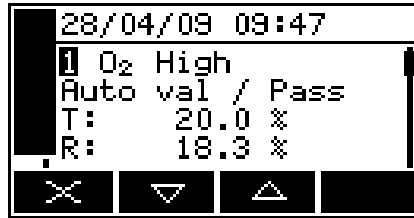



Figure 84 - The validation/calibration history screen (initial view)

4. Note also that the top line of the validation/calibration history screen will alternate between:

- "Calibration <x>/<y>" (as in Figure 86 above), where <x> is the number of the displayed calibration point and <y> is the total number of calibration points stored.
- "<date> <time>" (as in Figure 87), specifying the date and time of the displayed calibration point.



**Figure 85 - The validation/calibration history screen (alternate view)**

Use the  and  soft keys to scroll through and view the validation/calibration history screens for other validation/calibration points as required.



### 6.2.5 Calibrating the pressure sensor

Every time a high calibration of the measurement transducer is carried out, the pressure sensor is calibrated automatically. No further calibration is necessary.

## 6.3 Calibrating the Flowcube (F<sup>3</sup>) Flow Sensor (option)

If the flow sensor option has been fitted you must calibrate the flow sensor when you first calibrate the analyser and annually thereafter.

Use the following procedure to calibrate the flow sensor:

1. Select:  → Service → Flow alarm
2. Select the zero calibration option and stop the flow of gas through the analyser. Wait 3 minutes before pressing the  soft key.

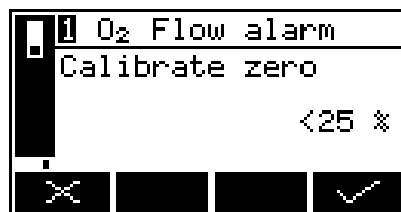

**Figure 86 - The flow calibrate zero screen**

3. Select the normal calibration option and restore the sample flow through the analyser. Wait 3 minutes before pressing the  soft key.

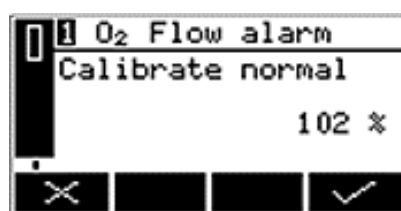

**Figure 87 - The flow calibrate normal screen**

## 7. GENERAL OPERATION



Sample and calibration gases must be as specified in Sections 2.4 and 2.6. If the pressure/flow rates are outside the ranges specified in Sections 2.4 and 2.6, you must regulate the gases externally, before they enter the analyser.

### 7.1 Checking the relay signal outputs

**Note:** Gas selection relays (Sample, Cal lo, Cal hi) are not effected during the signal relay override as this could cause hazardous gas flows.

If required, use the following procedure at any time to perform a check on the outputs of the signal relays fitted to the analyser:

1. Select:  → Service → Relay
2. Figure 88 shows the relay state (Energised or Deenergised) that the relay signals outputs will be set to when the override is active. Edit if required.

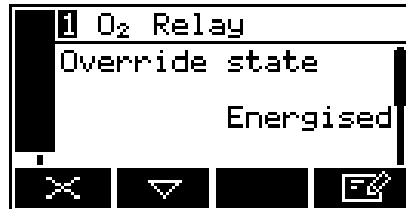



Figure 88 - The Relay override state screen

**Note:** When a relay is energised, the N/C-Common contacts will be open, and the N/O-Common contacts will be closed. The converse is true when the relay is deenergised.

3. Scroll to the relay override screen.
4. Select the "Yes" option, then press the  soft key. The relay outputs will now be set to the selected override state, and you can use your control/monitoring equipment (connected to the analyser) to monitor the relay signal outputs

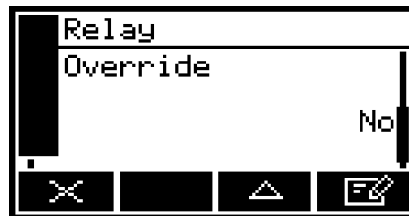

Figure 89 - The Relay override action screen

**Note:** The relay signal outputs freeze at the selected override signal state as long as the 'Override action' screen is displayed. As soon as another screen is displayed, the relay signal outputs will be updated to reflect the corresponding alarm, fault and range states.

## 7.2 Pressure compensation (option)

### 7.2.1 Introduction

When pressure compensation is on:

- A Pressure Compensation indicator is displayed on the Measurement screen (see Figure 6).
- The sample measurements shown on the Measurement screen (and provided as outputs) are pressure compensated measurements.
- If required, you can view the pressure compensated and uncompensated sample measurements at any time: refer to Section 7.2.3.

### 7.2.2 Switching pressure compensation on/off

To switch pressure compensation on/off, use the following procedure:

1. Select:  → Set Up → Pressure
2. The Pressure compensation select screen shows the current selection state:
  - "Yes" indicates that pressure compensation is on.
  - "No" indicates that pressure compensation is off.

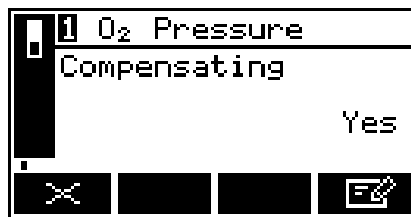



Figure 90 - The Pressure compensation

### 7.2.3 Viewing pressure effected measurements

When pressure compensation is on, use the following procedure to view simultaneous pressure compensated and uncompensated measurements:

1. Select:  → View → Pressure
2. On this screen:
  - The "Pre comp" value is the sample measurement before pressure compensation.
  - The "Post comp" value is the pressure compensated sample measurement.

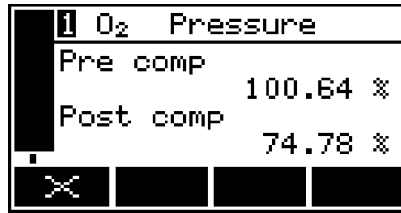

Figure 91 - The Pressure view screen

### 7.3 Checking the mA output

If required, use the following procedure at any time to perform a check on a mA output:

1. Select: → Service → mA output
2. Select the required 'Override' option.
3. Edit the displayed override value.
4. Press the soft key: an acceptance screen showing "No" will then be displayed. Select "Yes" to apply the override.

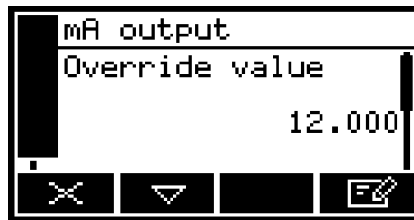

Figure 92 - The mA output override

5. The mA output will now be set to the override value you have selected. Use your control/monitoring equipment (connected to the analyser) to check that the output is correct.

**Note:** *The mA output freezes at the override value as long as the 'Override' screen is displayed. As soon as another screen is displayed, the mA output value will be updated to reflect the gas measurement.*

### 7.4 Viewing flow levels

Select: → View → Flow Alarm

- The flow level shown at 'A' is indicating flow rate of 119% of nominal flow.
- The flow level shown at 'B' is indicating flow rate of 35% of nominal flow.

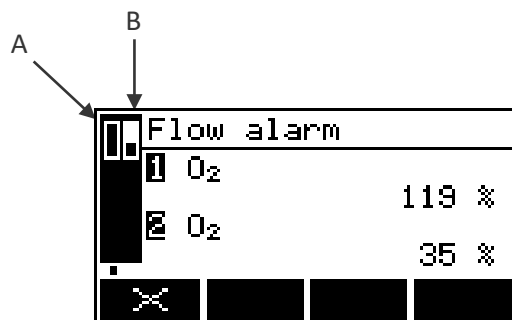

Figure 93 - Flow levels

## 7.5 Switching off the analyser

After you have switched off the analyser, when required or as necessary (for example, if you need to carry out plant/factory maintenance and will not use the analyser for several days):

- Ensure the gas inlet and outlets are blocked off (closed valve or protective caps supplied).
- Isolate/lockout the external electrical supply and disconnect the electrical supply cable from the analyser.



## 8. ROUTINE MAINTENANCE

---



The analyser must be maintained by a suitable skilled and competent person.



*La maintenance de l'analyseur doit être effectuée par une personne compétente et dûment formée.*



Sample and calibration gases may be toxic, asphyxiant or flammable. Never inspect the inlet filter, open the front cover of the sample/control compartment, or service or repair the analyser while such gases are still connected to it.



*Les gaz échantillon et de calibrage peuvent être toxiques, asphyxiants ou inflammables. Ne procédez jamais à l'inspection du filtre d'entrée, à l'ouverture du couvercle avant du compartiment échantillon/contrôle, ni à aucune autre intervention de maintenance ou de réparation sur l'analyseur tant que ces gaz y sont raccordés.*



Sample and calibration gases may be toxic, asphyxiant or flammable and hazardous concentrations may accumulate within the analyser during use. Always open the front cover of the sample/control compartment in a force-ventilated enclosure with a minimum volume of 17 m<sup>3</sup>, or in another appropriate environment, in which any hazardous gases are directed away from you.



*Les gaz échantillon et de calibrage peuvent être toxiques, asphyxiants ou inflammables et peuvent s'accumuler en concentrations dangereuses à l'intérieur de l'analyseur pendant l'utilisation. L'ouverture du couvercle avant du compartiment échantillon/contrôle doit toujours être effectuée dans une enceinte à ventilation mécanique (volume minimum de 17 m<sup>3</sup>) ou autre environnement permettant l'évacuation adéquate des gaz dangereux.*

### 8.1 Cleaning the analyser

When necessary, use a damp (but not wet) cloth to wipe clean the outer surfaces of the analyser, to prevent the entry of dust or other particulates into the breather vent or the interior of the analyser.

### 8.2 Inspection

It is recommended that the analyser is inspected for signs of corrosion. Particular care is should be taken when inspecting the door seals, sample inlet and outlet entries, mounting plate and the gland entries.

If a sample system or corrosive purge is being used, then the operation of these should be verified at regular intervals, no greater than annually. Failure of either the sample system or the corrosive purge can result in significant analyser damage and research has shown that sample system failures account for over 70% of analytical measurement field failures.

The pressure drop across the analyser is low, less than 1.0kPa (0.15psi) in most cases, if excessive pressure is required to generate a flow through the analyser it is an indication that the inlet sintered filter is blocked or contaminated. If this is the case, then this fitting can be removed and inspected or replaced.

### 8.3 Inspecting/replacing the fuse (when necessary)



Ensure that the electrical supply is isolated/locked out from the analyser. If you do not, there will be a danger of injury or death from electric shock.



*Assurez-vous que l'alimentation est isolée de l'analyseur et verrouillée. Dans le cas contraire, vous vous exposez à des blessures mortelles par électrocution.*



Do not remove the cover of the power/signal compartment if an explosive atmosphere may be present.



*Ne retirez pas le couvercle du compartiment alimentation/signalisation s'il y a un risque d'atmosphère explosive.*



The power/interface compartment cover is heavy. Ensure that you do not drop the cover once it is disengaged from the body of the analyser. If you do, you may injure yourself or damage other equipment. Any damage to the thread on the cover will compromise the analyser certification.



*Le couvercle du compartiment alimentation/interface est lourd. Veillez à ne pas le faire tomber après l'avoir dégagé du corps de l'analyseur. Vous risqueriez de vous blesser et d'endommager les autres équipements.  
Toute détérioration du filetage du couvercle invalidera la certification de l'analyseur.*



Place the cover carefully on a clean surface, resting on the exterior of the cover, so that the pregreased threads do not become contaminated.

If you suspect that the internal fuse has failed, use the following procedure to inspect it and replace if necessary:

1. Ensure that the external electrical supply is switched off and isolated/locked out from the analyser.
2. Refer to Figure 1. Use the 2 mm hexagonal key supplied to loosen the locking screw which secures the cover.
3. Unscrew the cover; that is, turn it anticlockwise. If necessary, fit a suitable metal bar between the protruding fins on the front of the cover to provide additional leverage.

4. When the cover is fully disengaged from the body of the analyser, remove it and place it carefully on a clean surface: see the caution above.
5. Refer to Figure 4. Remove the fuse (F101) and check the continuity across the fuse:
  - If there is continuity, the fuse has not failed: refit the fuse.
  - If there is no continuity, the fuse has failed: fit a new fuse of the correct type and rating.

## 8.4 Refit the power/interface compartment cover



The power/interface compartment cover is heavy. Ensure that you do not drop the cover when you refit it to the body of the analyser. If you do, you may injure yourself or damage other equipment.



*Le couvercle du compartiment alimentation/interface est lourd. Veillez à ne pas le faire tomber en tentant de le revisser sur le corps de l'analyseur. Vous risqueriez de vous blesser et d'endommager les autres équipements.*



Ensure that the pregreased threads of the cover do not become contaminated.

**Note:** *The threads on the cover are pregreased. You do not need to add any grease or sealant to the threads before you refit the cover.*

1. Refer to Figure 1. Carefully refit the cover to the body of the analyser, so that the threads on the rear of the cover are correctly aligned with the threads in the analyser: pick the cover up by its exterior, and do not touch or contaminate the pregreased threads on the cover.
2. Screw on the cover (that is, turn the cover clockwise) to secure it to the analyser.

**Note:** *It can help to turn the cover anticlockwise, up to one turn, till you feel or hear the threads align, before beginning to screw on the cover clockwise.*

3. Fully tighten the cover. If necessary, fit a suitable metal bar between the protruding fins on the front of the cover to provide additional leverage.
4. Use the 2 mm hexagonal key supplied to tighten the locking screw which secures the cover.
5. Ensure that the certification label is in the correct orientation. If necessary, press and turn the label until it is in the correct orientation.

**Note:** *If a new fuse fails immediately after you have fitted it, there may be an electrical fault in the analyser: contact Servomex or your Servomex agent.*

## 8.5 Use of the analyser with toxic gases



If you use the analyser to sample toxic gases, the concentrations of the gases sampled or used for calibration of the analyser may be above their respective threshold limit values. You must therefore regularly leak-test the analyser and associated equipment. If any leaks are found, do not continue to use the analyser or associated equipment until the leaks have been sealed.



*Si vous utilisez l'analyseur pour échantillonner des gaz toxiques, les concentrations de gaz échantillon ou de gaz de calibration peuvent excéder leurs seuils respectifs. Vous devez donc contrôler régulièrement l'étanchéité de l'analyseur et des équipements associés. Si des fuites sont détectées, vous devez y remédier avant de poursuivre l'utilisation de l'analyseur ou des équipements associés.*



When you carry out a leak test, do not exceed a maximum pressure of 34.5 kPa gauge (0.35 bar gauge, 5 psig) and do not introduce a sudden change of pressure into the analyser. If you do, you may damage it.



If you use a liquid to assist in leak testing, do not spill liquid onto any of the electrical components in the sample/control compartment.

If you use the analyser for toxic gas sample measurements, you must regularly leak-test the analyser and the associated sample inlet and outlet pipelines or hoses.

We recommend that you leak-test the analyser at least once every 6 months:

- If there are leaks within the analyser, it must be returned to Servomex for repair. Do not continue to use the analyser.
- You must seal any leaks in your sample pipelines or system.

**Note:** *When you leak-test, ensure that you do not exceed the maximum pressure, and do not increase the pressure in the analyser too quickly (see the caution above): we recommend that you allow at least 30 seconds to fully pressurise the analyser to the maximum pressure.*

## 8.6 Preventative maintenance

To minimise unscheduled analyser downtime, ensure the proper operation of the analyser and to comply with the guidelines of applicable regulatory bodies, we recommend that you utilise the SERVOSURE annual preventative maintenance program for your analyser.

The preventative maintenance program consists of a yearly inspection of the analyser, and repair of any faults, to ensure that the analyser meets its original factory specification. Once inspection and repair are complete, you will be provided with a full SERVOSURE report.

Note that you will always be informed in advance if any repairs or new parts are required for your analyser.

Contact Servomex or your local Servomex agent to arrange for a preventative maintenance contract.

This page intentionally blank.

## 9. SAMPLE SYSTEM INTEGRATION

---



The SERVOTOUGH Oxy is a precision analytical device, suitable for a wide variety of industrial applications. Though every effort has been taken to ensure that the analyser is highly robust to differing sample stream compositions, it should be noted that if the requirements of Section 2.4 and Section 2.5 are not met then the analyser can be damaged and the measurement invalidated.

### 9.1 Sample Systems



The analyser will be damaged if condensation is allowed to form within the measurement cell or pipe work. It is important that the sample gas dew points specified in Section 2.4 are maintained at all times.

**Note:** *It is recommended that sample systems contain a flow monitoring device on the outlet of the analyser, ideally with a status indication communicating back to the control room, or that the analyser is fitted with a Servomex Flowcube flow sensor option. Any failure in the sample flow can then be quickly diagnosed and corrective action taken.*

**Note:** *In the event of power failure to the analyser or the sample system, condensation can form within the sample pipework if the sample gas has a dew point below that of the ambient temperature.*

*It is recommended that if there is a power failure that the sample system contains sufficient protection and interlocks on coolers and "hot" sample elements to prevent gas flow through the analyser until these are at working temperature.*

*If the sample gas is considered corrosive, then it is recommended that during a power failure or while the sample system is not at operational conditions, that instrument air is used to purge the measurement pipework of the analyser.*

### 9.2 Corrosive Purge



Failure of the corrosive purge could result in damage to the electronics within the sample/control compartment, which could result in an analyser failure.



The corrosive purge gas must comply with the requirements of Section 2.5. If the purge gas is not dry or contains other contaminants, i.e. oil vapours, then this can result in damage to the electronics within the sample/control compartment, which could result in an analyser failure.

This page intentionally blank.





## 10. FAULT FINDING

### 10.1 Fault, Maintenance Required and SIP Statuses

#### 10.1.1 Status definitions



- Fault - A serious fault has been detected.
- Maintenance required - A maintenance required status has been raised, the analyser requires attention.
- Service in Progress (SIP) - During service operations (calibration, auto validation, I/O overriding) a service in progress status will be raised.









#### 10.1.2 Status Annunciations









Condition	LCD Icon	LED Annunciation	Relay Annunciation
Fault		Orange fault LED	Fault relay deenergised
Maintenance		None	Maintenance required relay energised
Service in Progress (SIP)		None	Service in progress relay energised







**Note:** All status conditions are listed in alphabetical order on the next 4 pages.









**Note:** The LCD icons are displayed on the measurement screen only (see Figure 6).







Message	Measurement screen icon	Recommended actions
Auto cal high fail		Check that the calibration gases are as specified in Section 2.4 and Section 2.6 and that the correct settings have been entered, then recalibrate the analyser again.
Auto cal low fail		Check that the calibration gases are as specified in Section 2.4 and Section 2.6 and that the correct settings have been entered, then recalibrate the analyser again.

Message	Measurement screen icon	Recommended actions
Auto cal low flow		Flow has fallen below the Fault Level set for the flow sensor during a calibration routine (very low flow): Check that there is sufficient gas flow into the transducer (see Section 2.4)
Auto val low flow		Flow has fallen below the Fault Level set for the flow sensor during a validation routine: Check that there is sufficient gas flow into the transducer (see Section 2.4)
Auto validate		Raised during auto validation of the transducer (see Section 5.15)
Auto val high fail		Check that the calibration gases are as specified in Section 2.4 and Section 2.6 and that the correct settings have been entered, then revalidate the analyser again.
Auto val low fail		Check that the calibration gases are as specified in Section 2.4 and Section 2.6 and that the correct settings have been entered, then revalidate the analyser again.
Calibration fault		Recalibrate (both low and high) as described in Section 6. If the fault persists, contact Servomex or your local Servomex agent for assistance.
Code fault		Contact Servomex or your local Servomex agent for assistance.
Communication fail		Turn the analyser off, and then turn it on again. If the fault message is then displayed again, contact Servomex or your local Servomex agent for assistance.

Message	Measurement screen icon	Recommended actions
Database fault		Turn the analyser off, and then turn it on again. If the fault message is then displayed again, contact Servomex or your local Servomex agent for assistance.
Date/Time invalid		This usually occurs because the electrical supply to the analyser has been switched off for more than a week. Switch on the electrical supply, then set the date/ time as described in Section 5.13. If the fault persists, contact Servomex or your local Servomex agent for assistance.
Fatal fault		Contact Servomex or your local Servomex agent for assistance.
Flow calibrate		Raised during calibration of the Flowcube flow sensor.
Flow H/W fault		Contact Servomex or your local Servomex agent for assistance.
Flow cal high diff		The zero and normal calibration points are too far apart, check normal flow is within limits (see Section 2.4) and re-calibrate the Flowcube flow sensor.
Flow cal low diff		The zero and normal calibration points are too close, check normal flow is within limits (see Section 2.4) and there is no flow during zero calibration. Re-calibrate the Flowcube flow sensor.
Flow temp fault		Contact Servomex or your local Servomex agent for assistance.

Message	Measurement screen icon	Recommended actions
High flow alarm	Configurable	Flow risen above the set level for the Flowcube flow sensor: Check that there is not excessive gas flow into the transducer (see Section 2.4). Check that the level has been set correctly and that calibration has been performed (see Section 6.3). Check sample is clean and without contaminants.
Low flow alarm 1 / Low flow alarm 2	Configurable	Flow has fallen below the set level for the Flowcube flow sensor: Check that there is sufficient gas flow into the transducer (see Section 2.4). Check that the level has been set correctly and that calibration has been performed (see Section 6.3).
Heater fault		Contact Servomex or your local Servomex agent for assistance.
mA fault		Ensure that the electrical cabling connected to the analyser is not open circuit. Turn the analyser off, and then turn it on again. If the fault persists, contact Servomex or your local Servomex agent for assistance.
mA not detected		Contact Servomex or your local Servomex agent for assistance.
mA overridden		Raised during checking of the mA output (see Section 7.3).
mA reset		Contact Servomex or your local Servomex agent for assistance.
P calib fault		Calibrate the pressure compensation transducer again.
P high fault		Adjust pressure. Contact Servomex or your local Servomex agent for assistance.

Message	Measurement screen icon	Recommended actions
P H/W fault		Contact Servomex or your local Servomex agent for assistance.
P low fault		Adjust pressure. Contact Servomex or your local Servomex agent for assistance.
Power config fault		Contact Servomex or your local Servomex agent for assistance.
Relay not detected		Contact Servomex or your local Servomex agent for assistance.
Relays overridden		Raised when the alarm and status relays have been overridden (see Section 7.1).
Remote activation		Raised when the Service in Progress status is remotely activated via the SIP digital inputs on the Calibration Card.
Rem lo cal denied		Raised when a remote low calibration cannot execute because the current reading is outside tolerances (see Section 5.15.4).
Rem hi cal denied		Raised when a remote high calibration cannot execute because the current reading is outside tolerances (see Section 5.15.4).
Static RAM fault		Turn the analyser off, and then turn it on again. If the fault message is then displayed again, contact Servomex or your local Servomex agent for assistance.
Sw IP not detected		Contact Servomex or your local Servomex agent for assistance.
Temperature fault		Reduce temperature to within environmental limits or contact Servomex or your local Servomex agent for assistance.

Message	Measurement screen icon	Recommended actions
Transducer error		Ensure that you are using the analyser in the specified operating conditions (refer to Section 2). If the fault persists, contact Servomex or your local Servomex agent for assistance.
Tx calibrate		Raised during manual, remote or auto calibration of the transducer.
Tx incorrect type		Contact Servomex or your local Servomex agent for assistance.
Tx maintenance		Recalibrate (both low and high) as described in Section 6. If this does not clear the fault, turn the analyser off, and then turn it on again. If the fault message is then displayed again, contact Servomex or your local Servomex agent for assistance.
Tx not detected		Contact Servomex or your local Servomex agent for assistance.
Very low flow		Flow has fallen below the Fault Level set for the Flowcube flow sensor: Check that there is sufficient gas flow into the transducer (see Section 2.4).

## 10.2 Viewing messages

### 10.2.1 Active messages

1. Select  → Status → Active
2. Each message status screen shows:
  - Date and time of message.
  - The message type ("Fault", "Maintenance reqd" or "Service in Progress").
  - The message itself.

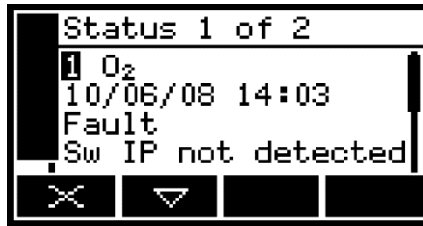



Figure 94 - The Message status screen

3. Refer to Section 10.1 for the recommended actions associated with the displayed messages.

### 10.2.2 View history messages

1. Select  → Status → View History
2. Each message shows:
  - Date and time of message.
  - The message type ("Fault", "Maintenance rqd" or "Service in Progress").
  - The message itself.
  - The status of the entry ON or OFF.

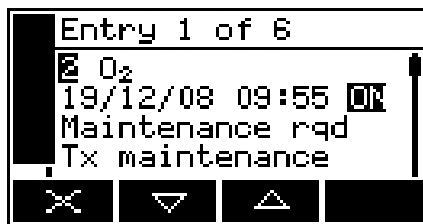

Figure 95 - The Message status screen

3. Refer to Section 10.1 for the recommended actions associated with the displayed messages.

**Note:** A maximum of 100 status messages can be stored.

## 10.3 General fault finding

For general analyser fault finding, refer to the table on the following pages.

If you have read through the table and still cannot rectify a fault, or cannot identify the cause of a fault, contact Servomex or your local Servomex agent for assistance.

Fault symptom	Recommended actions
The Fault LED is on.	<p>Check any current fault messages (see Section 10.2), and carry out the recommended actions (see Section 10.1).</p> <p>If there are no applicable fault messages stored, or if you cannot rectify the fault after you have carried out the recommended actions:</p> <p>Switch off the analyser, then switch it on again.</p> <p>If the fault persists, contact Servomex or your local Servomex agent for assistance.</p>
The software health indicator is not moving on the display.	Carry out the recommended actions for the "The Fault LED is on" symptom above.
" - - - - " is displayed instead of a sample measurement.	<p>This indicates a possible measurement error, or a communications error between the transducer and the analyser controller.</p> <p>Check that the analyser is not being knocked, moved, or subjected to high levels of vibration during sample measurements.</p> <p>If the analyser is not being knocked, moved or subjected to vibration and the fault persists, contact Servomex or your local Servomex agent for assistance.</p>
Analyser response is slow.	<p>Check that the sample gas inlet is not blocked, and that the sample gas supply to the analyser is not restricted.</p> <p>Check that the sample gas outlet is not blocked, and that any pipes connected to the outlet are not restricted.</p> <p>Check that the inlet and outlet sintered filters are not blocked or show signs of moisture or particle contamination.</p> <p>Check that the sample gas supply pressure is correct: refer to Section 2.4.</p>



Fault symptom	Recommended actions
Analyser measurements are not as expected.	<p>Check that the correct display units have been selected, and that the units conversion factor has been correctly entered (see Section 5.19).</p> <p>If you are using pressure compensation, check that the pressure transducer is switched on (see Section 7.2.2).</p> <p>Ensure there are no leaks in the pipework.</p>
Analyser measurements are unstable.	<p>Check that the sample gas supply pressure is correct: see Section 2.4.</p> <p>Check that the analyser is not being subjected to high levels of vibration and ensure there are no leaks.</p> <p>Check that the sample gas inlet is not blocked, and that the sample gas supply to the analyser is not restricted.</p> <p>Ensure there are no leaks in the pipework.</p>
The analyser will not calibrate.	<p>Check that the correct low and high calibration gases are being used: see Section 2.6.</p> <p>Check that the sample gas inlet is not blocked, and that the sample gas supply to the analyser is not restricted.</p> <p>Check that the sample gas outlet is not blocked, and that any pipes connected to the outlet are not restricted.</p>
The analyser will not switch on.	<p>Check that the external supply is switched on, and that no fuse or over-current device in the external supply has operated to switch off the supply.</p> <p>If the external electrical supply is correct, switch off and isolate the supply and check that the supply is correctly connected to the analyser.</p> <p>If the supply is correctly connected, the operating fuse may have failed; inspect and replace the fuse if necessary: refer to Section 8.3.</p>

Fault symptom	Recommended actions
The analyser display is blank or is too dark.	<p>Check that the ambient temperature is within the valid analyser operating temperature range: refer to Section 2.2.</p> <p>Check that the display contrast adjustment has been correctly set (refer to Section 5.11), and has not been altered.</p>
The measurement alarms are activating more often than expected.	<p>Check that the analyser is not being knocked, moved, or subjected to high levels of vibration during sample measurements.</p> <p>Check that the alarm modes, alarm levels and hysteresis levels have been correctly set: refer to Section 5.20.</p>
The mA output is at 0 or 21.5 mA.	<p>If you have configured the milliamp output to jam high or jam low, check whether a fault condition exists (see Section 5.16). Otherwise, contact Servomex or your local Servomex agent for assistance.</p>
The mA output is not as expected.	<p>Ensure that the electrical cabling connected to the analyser is not open circuit.</p> <p>Check that the milliamp output is calibrated correctly (see Section 5.16.4).</p> <p>Check that you have selected the correct Range (see Section 5.16.3).</p>
A relay signal output is not as expected.	<p>Check that the signal cable is correctly connected to the analyser: refer to Section 5.3.3, Section 5.3.4 or Section 5.3.4</p>

## 11. STORAGE AND DISPOSAL

---

### 11.1 Storage

Refit any protective plastic covers (see Section 3) and place the analyser and any associated equipment in its original packaging before storage. Alternatively, seal it inside a waterproof plastic bag, sack, or storage box.

Store the analyser and any associated equipment in a clean, dry area. Do not subject it to excessively hot, cold, or humid conditions: see Section 2.2.

### 11.2 Disposal

Dispose of the analyser and any associated equipment safely, and in accordance with all of your local and national safety and environmental requirements.

**Note:** *The analyser is not suitable for disposal in municipal waste streams (such as landfill sites, domestic recycling centres and so on). Refer to Appendix A6 for disposal requirements in accordance with the WEEE Directive within the EC.*

**Note:** *If you send the analyser to Servomex or your local Servomex agent for disposal, it must be accompanied by a correctly completed decontamination certificate.*

This page intentionally blank.

## 12. SPARES

---



Do not use spares other than those specified below, and do not attempt to carry out any maintenance procedures other than those specified in this manual. If you do, you can damage the analyser and invalidate its certification, and use of the analyser in a hazardous area may result in a risk of fire or explosion.



*N'utilisez jamais de pièces détachées autres que les pièces répertoriées ci-après. Ne tentez aucune procédure de maintenance autre que les procédures décrites dans ce manuel. Vous risqueriez d'endommager l'analyseur, auquel cas la certification sera automatiquement invalidée et toute utilisation de l'analyseur en zone dangereuse présentera un risque d'incendie ou d'explosion.*

The standard spares available for the analyser are shown below. You can order these spares from Servomex or your Servomex agent.

---

<b>Spare</b>	<b>Part Number</b>
Fuse F101: 2 A for 100-120 V operation	204629
Fuse F101: 1 A for 220-240 V operation	2531-2630
Inlet & Outlet filter / restrictor kit standard, Viton o rings	S1910982
Inlet & Outlet filter / restrictor kit solvent resistant, Chemraz o rings	S1910983
Spare insulation kit - cover for inlet / outlet (sample heating only)	S1910981

---

This page intentionally blank.

# Appendix A IMPLEMENTATION GUIDE FOR MODBUS COMMUNICATIONS

## A.1 Introduction

This appendix details the implementation and use of the Modbus protocol in the SERVOTOUGH Oxy Analyser.

## A.2 References

Document “MODBUS over Serial Line Specification & Implementation guide V1.0 Nov 02” Modbus web site modbus.org.

## A.3 Modbus setup

The Modbus setup form will allow the user to configure the following parameters: Default values are in Bold.

Parameters	Options	Comments
Address	1 to <b>247</b>	Slave address of unit.
Mode	ASCII or <b>RTU</b>	Select serial transmission mode.
Baud rate	2400, 4800, <b>9600</b> , 19200, 38400	
Parity	Odd, <b>Even</b> , None.	

## A.4 Supported function codes

For simplicity, only the following function codes will be supported.

Function	Description	Usage
01	Read coils	Read calibration status, pump state, etc.
02	Read discrete inputs	Read faults and alarm states.
03	Read holding registers	Read settings.
04	Read input registers	Read measurements, units, etc.
05	Write single coil	Change modes, perform calibration etc.
06	Write single register	Change single setting.
08	Sub Function 00= Return query data	Diagnostic to test communications.
16	Write multiple registers	Change multiple settings

## A.5 Exception codes

If an error should occur while processing a message one of the following exception codes will be returned by the instrument.

Code	Condition	Meaning
01	Illegal function	Requested function code is not supported.
02	Illegal data address	The combination of data address and transfer length is invalid for this function.
03	Illegal data value	A value contained in the query data field is not an allowable value. This indicates a fault in the structure of the remainder of a complex request. This does NOT mean that a value to be stored in a register is incorrect as Modbus has no means of determining what is legal for any particular register.
04	Slave device failure	An unrecoverable error occurred while the unit was attempting to perform the requested action.

## A.6 Addressing

Addresses in Modbus ADU (application data unit), run from 1—N, whereas addresses in the Modbus PDU (protocol data unit) run from 0—N. This appendix gives addresses in the ADU model. Depending on the particular Modbus master, addresses may have to be entered as they are given or have 1 subtracted from them. For example, to read register 101 an address of 100 may be needed.

## A.7 Floating point numbers

Floating point numbers (e.g. 12.34, -1012.32, etc.), are digitally represented using the IEEE-754 format. Single precision floating point numbers are used throughout and they require 32 bits of data. Since a Modbus register holds 16 bits it takes 2 registers to represent a floating point number. We default to having the most significant word of the float, bits 16-31, in the first register, and the least significant word, bits 0-15, in the next register. This order can be reversed by setting a coil.

## A.8 System data mapping

Read-only access to system data will be provided in a block of 100 registers. These can be accessed as input registers using function code 04.



Register	Name	Comments
1 - 7	Serial Number	ASCII text, 14 characters max, terminated by a zero.
8 - 15	Software Version	ASCII text, 16 characters max, terminated by a zero.

### A.9 Transducer data mapping

The transducer will provide read-only access to its measurements and associated data in blocks of input registers that can be read with function code 04.

A block of 100 registers is allocated for the transducer to provide the means of supplying the measurement and other transducer related data as follows:

Register	Name	Comments
101 – 200	Transducer	Measurements and data for each transducer

The following table shows the assignment for the transducer. Each register provides 2 bytes of data.

Register	Name	Comments
101 - 102	Measurement	As seen on the measurement display. Floating point number.
103 - 104	Filtered measurement	Basic measurement, filtered. Floating point number.
105 - 106	Pressure compensated measurement	Filtered and pressure compensated measurement. Floating point number.
107 - 108	PMR	Primary measurement range
109	Warming state	0 = Not warming, 1 = Warming
110 - 112	Formula	Gas formula. ASCII text, 5 characters max, terminated by a zero.
113 - 116	Units	Measurement units. ASCII text, 7 characters max, terminated by a zero.
117	Auto val state	0 = Idle, 1 = Pre-warning, 2 = Inerting, 3 = Flushing, 4= Validating/Calibrating
118	Auto val gas	0 = Low gas, 1 = High gas, 2 = Sample gas
119	Auto val finishing	0 = Not finishing, 1 = Finishing
120	Auto val fail state	0 = Auto validation OK, 1 = Auto validation failed
121	Active analogue output range	0 = Range 1, 1 = Range 2
122	Flow	Current flow through the transducer in percent

## A.10 System fault mapping

Read-only access to system fault information will be provided in a block of 100 registers. These can be accessed as discrete inputs using function code 02 or as input registers using function code 04. Reading them as discrete inputs provides a simple bit result for each, 0 for off and 1 for on. Reading them as input registers provides information on their NAMUR status, as follows:

- 0 = off,
- 1 = fault,
- 2 = maintenance required,
- 3 = service in progress.

The fault, maintenance required, and service in progress faults provide a summary of the other states and can only be off or on. The registers are assigned as follows:

Register	Name	Comments
1001	Fault	If any system fault exists.
1002	Maintenance required	If any system maintenance required status exists.
1003	Service in progress	If any system service in progress status exists.
1005	Date/Time invalid	System clock needs setting.
1006	Code fault	the programmed software has become corrupted.
1007	Database fault	A fault occurred when using the database.
1012	Static RAM fault	A fault in the internal memory has been detected.

### A.11 Transducer fault and alarm mapping

Read-only access to transducer fault and alarm information will be provided in a block of 100 registers and coils. These can be accessed as discrete inputs using function code 02 or as input registers using function code 04. Reading them as discrete inputs provides a simple bit result for each, 0 for off and 1 for on. Reading them as input registers provides information on their NAMUR status, as follows:

- 0 = off,
- 1 = fault,
- 2 = maintenance required,
- 3 = service in progress.

Alarm 1 and alarm 2 are not faults and can only be off or on.

The fault, maintenance required, and service in progress faults provide a summary of the other states and can only be off or on. The registers are assigned as follows:

Register	Name	Comments
1101-1200	Transducer	Measurements and data for each transducer

Each input within the block for the transducer is assigned as follows:

Register	Name	Comments
1101	Alarm 1	Alarm 1 is active or latched.

<b>Register</b>	<b>Name</b>	<b>Comments</b>
1102	Alarm 2	Alarm 2 is active or latched.
1103	Fault	If any transducer fault exists.
1104	Maintenance required	If any maintenance required status exists.
1105	Service in progress	If any service in progress status exists.
1106	Transducer maintenance fault	Internal transducer fault.
1107	Transducer error	Internal transducer fault.
1108	Transducer fatal fault	Internal transducer fault.
1109	Heater fault	Transducer heating has failed.
1110	Sample heater fault	Transducer sample heating has failed.
1111	Calibration fault	Transducer needs calibrating.
1112	Communication fail	Transducer not responding.
1113	Incorrect transducer type	Incorrect type of transducer fitted.
1114	Transducer not detected	Transducer is unplugged or broken.
1115	Low calibration fail	Auto cal low failed.
1116	High calibration fail	Auto cal high failed.
1117	Low validation fail	Auto val low failed.
1118	High validation fail	Auto val high failed.
1119	Remote low cal denied	Remote low calibration denied.
1120	Remote high cal denied	Remote high calibration denied.
1121	Milliamp fault	Hardware fault detected.
1122	Milliamp not detected	Card is missing or the incorrect type has been fitted.
1123	mA reset	A time out occurred on the mA card.
1124	Volt fault	Hardware fault detected.
1125	Volt not detected	Card missing or the incorrect type has been fitted.

<b>Register</b>	<b>Name</b>	<b>Comments</b>
1126	Volt reset	A time out occurred on the volt card.
1127	Pressure calibration	Pressure needs calibrating.
1128	Pressure fail	Hardware fault detected.
1129	Pressure low	Pressure low fault.
1130	Pressure high	Pressure high fault.
1131	Relay not detected	Card missing or incorrect type has been fitted.
1132	Switch input not detected	Card missing or incorrect type has been fitted.
1133	Flow fail	Hardware fault detected.
1134	Low flow alarm 1	Flow has fallen below flow alarm level 1
1135	Low flow alarm 2	Flow has fallen below flow alarm level 2
1136	Remote service in progress	Switch input has activated service in progress.
1137	Transducer calibration mode	Calibration mode is active.
1138	Auto validation/calibration.	Sequence is in progress
1139	Milliamp service in progress	Calibration or override in progress.
1140	Volt service in progress	Calibration or override in progress.
1141	Pressure service in progress	Calibration in progress.
1142	Relay service in progress	Override in progress.
1143	Flow service in progress	Calibration in progress.
1145	High Flow Alarm	Flow has risen above the high flow alarm level
1146	Flow temperature fault	Flow hardware has a temperature fault
1147	Flow cal high diff	Zero and normal flow calibration points are too far apart
1148	Flow cal low diff	Zero and normal flow calibration points are too close together

Register	Name	Comments
1149	Flow temp fault	Temperature fault on flow sensor

## A.12 System setup mapping

System data will be available with read-write access in blocks of holding registers. This data can be read with function code 03 and written with function codes 06 and 16.

Register	Name	Comments
<b>Clock</b>		
1	Year	0-99
2	Month	1-12
3	Date	1-31
4	Hour	0-23
5	Minute	0-59
6	Second	0-59
<b>Calibration set up</b>		
7	Linked	0=No, 1=Yes.
<b>Switch input</b>		
8	Switch input function	0=Disabled, 1=Remote cal, 2=Auto val.

## A.13 Transducer setup mapping

The transducer will provide read-write access to various setup data in blocks of holding registers that can be read with function code 03 and written with function codes 06 and 16.

Each register provides 2 bytes of data so it takes 2 registers each to store a 4 byte floating point measurement value.

A block of 100 registers is allocated for each transducer to provide the means of supplying the transducer related setup data as follows:

Register	Name	Comments
101 – 200	Transducer	Transducer related data.

The following table shows the assignment for the transducer. Each register provides 2 bytes of data.

Register	Name	Comments
<b>Analogue Output</b>		
101-102	Range 1 low	Float.
103-104	Range 1 high	Float.
105-106	Range 2 low	Float.
107-108	Range 2 high	Float.
109	Range mode	0=Range 1, 1=Range 2, 2=Auto range.
110	Freeze	0=Follow, 1=Freeze.
111	Jam	0=None, 1=low, 2=high.
112	Output range	0=0-20mA, (0-10V), 1=4-20mA.
113-114	Under range	Float.
115-116	Change over point	Float.
117-118	Hysteresis	Float.
<b>Cross Interference</b>		
119-120	Offset	Float.
<b>Auto validation</b>		
121-122	Low target	Float. Also calibration target.
123-124	Low tolerance	Float.
125-126	High target	Float. Also calibration target.
127-128	High tolerance	Float.

<b>Register</b>	<b>Name</b>	<b>Comments</b>
129	Type	0=low, 1=high, 2=low and high, 3=high and low.
130	Mode	0=validate, 1=calibrate.
131	Pre-warning phase	0=No, 1=Yes.
132	Pre-warning seconds	Integer.
133	Inerting phase	0=No, 1=Yes.
134	Inert gas	0=low, 1=high.
135	Inert seconds	Integer.
136	Flush seconds	Integer.
137	Timer	0=Off, 1=On.
138	Start year	0-99.
139	Start month	1-12.
140	Start date	1-31.
141	Start hour	0-23.
142	Start minute	0-59.
143	Repeat hour	Integer.
<b>Pressure</b>		
144	Compensating	0=No, 1=Yes.
<b>Alarm set up</b>		
145	Alarm 1 mode	0=None, 1=low, 2=high.
146	Alarm 1 latching	0=No, 1=Yes.
147-148	Alarm 1 level	Float.
149-150	Alarm 1 hysteresis	Float.
151	Alarm 2 mode	0=None, 1=low, 2=high.
152	Alarm 2 latching	0=No, 1=Yes.
153-154	Alarm 2 level	Float.



Register	Name	Comments
155-156	Alarm 2 hysteresis	Float.
<b>Flowcube Flow Sensor</b>		
157	Low flow 1 level	A status will be raised if flow falls to this level
158	Low flow 2 level	A status will be raised if flow falls to this level
159	Low flow 1 status type	The type of status to use for the low flow 1 alarm 0=None, 1=Fault, 2=Maintenance Required.
160	Low flow 2 status type	The type of status to use for the low flow 2 alarm 0=None, 1=Fault, 2=Maintenance Required.
161	High flow status type	The type of status to use for the high flow alarm 0=None, 1=Fault, 2=Maintenance Required.
<b>Relays</b>		
162	Fault relay active state	Relay state when fault is raised 0=deenergised, 1=Energised
163	Maintenance required relay active state	Relay state when maintenance required is raised 0=deenergised, 1=Energised
164	Service in progress relay active state	Relay state when service in progress is raised 0=deenergised, 1=Energised
165	Alarm 1 relay active state	Relay state when measurement alarm 1 is active 0=deenergised, 1=Energised
166	Alarm 2 relay active state	Relay state when measurement alarm 2 is active 0=deenergised, 1=Energised
167	Range relay active state	Relay state when mA range 2 is selected 0=deenergised, 1=Energised

## A.14 System control

System control will be provided using a block of coils that can be written to using function code 05. Reading the same coils with function code 01 provides status information.

Coil	Name	Comments
1	Floating point order	Changes the order of the Modbus registers when dealing with 32-bit floating point numbers. 0=Big-endian, e.g. 40001=high word, 40002=low word (default). 1=Little-endian, e.g. 40001=low word, 40002=high word.
2	User interface busy	0=Idle (on main screen), 1=Busy, user interface is in use. Write 1 to stop the user interface (keys) being used.

### A.15 Transducer control

Transducer control will be provided using a block of coils that can be written to using function code 05. Reading the same coils with function code 01 provides status information.

A block of 100 coils is reserved for each transducer as follows:

Coil	Name	Comments
101-200	Transducer 1	

The coils for transducer 1 are shown in the following table:

Coil	Name	Comments
<b>Measurement</b>		
101	Calibration mode on/off	0=off (normal), 1=On (alarms masked, jamming etc). Write 1 to turn calibration mode on.
102	Low calibration gas	0=Sample gas, 1=low calibration gas.
103	High calibration gas	0=sample gas, 1=High calibration gas.
104	Low calibrate	0=Idle, 1=low calibration in progress. Write 1 to initiate low calibration.
105	High calibrate	0=Idle, 1=high calibration in progress. Write 1 to initiate a high calibration.
106	Start auto val	0=Idle, 1=Auto val in progress. Write 1 to start an auto validation/ calibration.
107	Stop auto val	0=Auto val in progress and can be stopped,

---

1=Stop N/A.  
Write 1 to stop an auto validation/ calibration.

---

### Flowcube Flow Sensor

---

111 Calibrate flow mode 0= Normal, 1= Calibrate mode.

---

112 Calibrate zero flow 1=Calibrate at 0% flow.

---

113 Calibrate nominal span flow 1=Calibrate at 100% flow.

---

### Analogue Output

---

114 Calibration mode 0= Normal, 1= Calibration mode.

---

115 Decrease output level 1= Step down.

---

116 Increase output level 1= Step up.

---

### Relays

---

117 Service mode 0= Normal, 1= Service mode.

---

118 Relay state during service 0= De-energised, 1= Energised.

---

### Remote service in progress

---

119 Remote Service in Progress 0= Inactive, 1= Active.

---

### Auto validation

---

120 Auto validation mode 0= Validate, 1= Calibrate.

---

This page intentionally blank.

## Appendix B CONFIGURING THE MODBUS PARAMETERS

If your analyser has the Modbus output (either RS485 or Ethernet), you must configure the communications parameters to suit the requirements of the network to which you have connected the analyser.

The cable connections are shown in Section 5.3.5.

**Note:** All screen shots show the default setting.

These values are supervisor password protected. Your network administrator will advise you of the necessary parameters that will be required to be entered.

### B.1 RS485





1. Select:  → Settings → Comms parameters.
2. The first screen (see Figure 96) requests the communication mode. This can be RTU or ASCII.
3. Press the  softkey to change the value.



Figure 96 - Comms Parameters Mode Screen

**Note:** Use 8 bits for RTU and 7 bits for ASCII.

4. Use the  softkey to select the next parameter:
5. Node address, this can be anything from 1 to 247. Use the  and  soft keys to select the correct value.

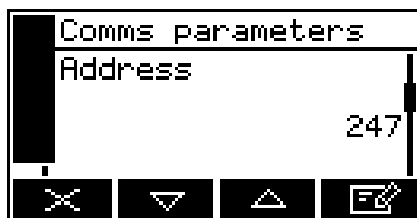



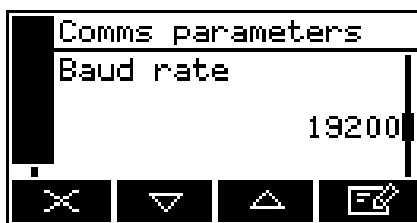





Figure 97 - Comms Parameters Node address screen

6. Use the  and  soft keys to select the next parameter:
7. Baud Rate, this can be anything 2400, 4800, 9600, 19200 or 38400. Use the  and  soft keys to select the correct value.



**Figure 98 - Comms Parameters Baud rate screen**



8. Use the  and  soft keys to select the next parameter.
9. Parity, this can be none, even or odd. Use the  and  soft keys to select the correct value.



**Figure 99 - Comms Parameters Parity screen**

## B.2 TCP (Ethernet)



**Note:** Each parameter consists of a 4-octet address in the form xxx.xxx.xxx.xxx where x represents a digit, each xxx octet can be in the range 000 to 255.

1. Select:  → Settings → Comms parameters.
2. The first screen requests the IP address, (always communicates in RTU mode). Use the  and  soft keys to select the correct value.



**Figure 100 - Comms Parameters IP Address screen**

**Note:** The IP address must be set to a unique value in the network.

3. Use the  and  soft keys to select the next parameter:
4. Subnet mask, sets the subnet mask for the network. A provisional mask is generated automatically by the control unit whenever a new IP address is entered that falls into a different class. The mask may then be altered manually if required by clicking  soft key.

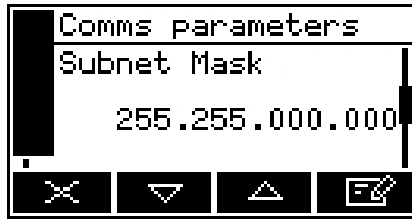



Figure 101 - Comms Parameters Subnet mask screen

5. Use the  and  soft keys to select the next parameter:
6. Gateway address, or router, allows communication to other LAN segments. The gateway address should be the IP address of the router connected to the same LAN segment as the unit. The gateway address must be within the local network.

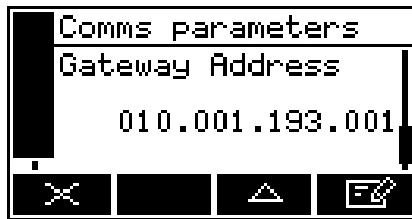

Figure 102 - Comms Parameters Gateway address screen

This page intentionally blank.



## Appendix C DISPLAY UNIT CONVERSION FACTORS

When you select display units as described in Section 5.19, you must ensure that you also enter the correct units conversion factor, as shown in the table below:

To convert from *	to †	use the units conversion factor
%	ppm	10000
ppm	%	0.0001
ppm	vpm	1
ppm	mg/m <sup>3</sup>	1.4277
%	mg/m <sup>3</sup>	14277
%	mol/mol	0.01
ppm	mol/mol	#

\* Measurement default units.

† Selected display units.

# This conversion is not supported.

**Note:** To return to the measurement default units, select the "off" units selection option and set the units conversion factor to "1": see Section 5.19.

This page intentionally blank.

## Appendix D PARAMAGNETIC CORRECTION FACTORS

For a paramagnetic oxygen measurement, the composition of any typical background gas in the gas sample will have a minor effect on the analyser measurement. For an analyser which has been 'Lo' calibrated with N<sub>2</sub> (nitrogen) and 'Hi' calibrated with O<sub>2</sub>, some examples of cross-interference errors (that is, O<sub>2</sub> measurement errors) in gases which contain 100% of a background gas are shown below.

Background gas	Error	Background gas	Error
Hydrogen	0.26%	Methane	-0.18%
Carbon dioxide	-0.30%	Propane	-0.87%

**Note:** *The correction is directly proportional to the concentration of the background gas in the sample being measured, and in many cases can be ignored.*

**Note:** *All corrections must be calculated using 60°C data from the tables below.*

If you cannot ignore the error, you can use the procedure in Section 5.18.2 to enter a compensation to correct for the error. Example corrections are shown below.

**Note:** *Example: If you are measuring O<sub>2</sub> (oxygen) in a background of Carbon dioxide -0.30 should be entered as the cross interference offset.*

**Note:** *Example: If you are measuring 10% Oxygen in a background of 70% Hydrogen and 20% Carbon Dioxide the correction factor would be:*

*The correction factor assumes 100% of background gas, so you must firstly correct for the nominal process oxygen concentration:*

*Total background concentration = 70% + 20% = 90%*

*Correct background concentrations for 0% oxygen:*

*(100% / 90%) x 70% = 77.8% Hydrogen*

*(100% / 90%) x 20% = 22.2% Carbon Dioxide*

*For 100% Hydrogen the correction is 0.26, so for 77.8% it is 0.202*

*For 100% Carbon Dioxide the correction is -0.30, so for 22.2% it is -0.067*

*So the total correction factor in this case is -0.067 + 0.202 = 0.135*

Pure gas	Formula	Molar mag.susc  x 10 <sup>-6</sup>	Zero offset			
			20°C	50°C	60°C	110°C
Acetaldehyde	CH <sub>2</sub> CHO	-22.70	-0.31	-0.34	-0.35	-0.40
Acetic acid	CH <sub>3</sub> CO <sub>2</sub> H	-31.50	-0.56	-0.62	-0.64	-0.74
Acetone	CH <sub>3</sub> COCH <sub>3</sub>	-33.70	-0.63	-0.69	-0.71	-0.82
Acetylene	HCCH	-20.80	-0.25	-0.28	-0.29	-0.33
Acrylonitrile	CH <sub>2</sub> =CHCN	-24.10	-0.35	-0.39	-0.40	-0.46
Allyl alcohol	CH <sub>2</sub> CHCH <sub>2</sub> OH	-36.70	-0.71	-0.79	-0.81	-0.93
Ammonia	NH <sub>3</sub>	-18.00	-0.17	-0.19	-0.20	-0.23
Argon	Ar	-19.60	-0.22	-0.24	-0.25	-0.29
Benzene	C <sub>6</sub> H <sub>6</sub>	-54.84	-1.24	-1.36	-1.41	-1.62
Boron chloride	BCl <sub>3</sub>	-59.90	-1.38	-1.53	-1.57	-1.81
Boron trifluoride	BF <sub>3</sub>	-19.00	-0.20	-0.22	-0.23	-0.26
Bromine	Br <sub>2</sub>	-73.50	-1.78	-1.96	-2.02	-2.32
1,2 Butadiene	C <sub>4</sub> H <sub>6</sub>	-35.60	-0.68	-0.75	-0.77	-0.89
1,3 Butadiene	C <sub>4</sub> H <sub>6</sub>	-30.60	-0.54	-0.59	-0.61	-0.70
N-Butane	C <sub>4</sub> H <sub>10</sub>	-50.30	-1.11	-1.22	-1.26	-1.45
iso-Butane	(CH <sub>3</sub> ) <sub>2</sub> CHCH <sub>2</sub>	-51.70	-1.15	-1.26	-1.30	-1.50
1 Butene	CH <sub>3</sub> CH <sub>2</sub> CH=CH <sub>2</sub>	-41.10	-0.84	-0.93	-0.96	-1.10
N-Butyl acetate	CH <sub>3</sub> COOC <sub>4</sub> H <sub>9</sub>	-77.50	-1.89	-2.09	-2.15	-2.47
iso-Butylene	(CH <sub>3</sub> ) <sub>2</sub> CH=CH <sub>2</sub>	-44.40	-0.94	-1.03	-1.06	-1.22
1 Butyne (Ethylacetylene)	CH <sub>3</sub> C≡CH	-43.50	-0.91	-1.00	-1.03	-1.19
Carbon dioxide	CO <sub>2</sub>	-21.00	-0.26	-0.29	-0.30	-0.34
Carbon disulphide	CS <sub>2</sub>	-42.20	-0.87	-0.96	-0.99	-1.14
Carbon monoxide	CO	-9.80	0.06	0.07	0.07	0.08
Carbon tetrachloride	CCl <sub>4</sub>	-66.60	-1.58	-1.74	-1.79	-2.06

Pure gas	Formula	Molar mag.susc  x 10 <sup>-6</sup>	Zero offset			
			20°C	50°C	60°C	110°C
Carbon tetrafluoride	CF <sub>4</sub>	-31.20	-0.55	-0.61	-0.63	-0.72
Chlorine	Cl <sub>2</sub>	-40.50	-0.82	-0.91	-0.94	-1.08
Chloroethanol	ClCH <sub>2</sub> CH <sub>2</sub> OH	-51.40	-1.14	-1.25	-1.29	-1.49
Chloroform	CHCl <sub>3</sub>	-59.30	-1.37	-1.51	-1.55	-1.78
Cumene	(CH <sub>3</sub> ) <sub>2</sub> CHC <sub>6</sub> H <sub>5</sub>	-89.53	-2.24	-2.47	-2.55	-2.93
Cyclohexane	C <sub>6</sub> H <sub>12</sub>	-68.13	-1.62	-1.79	-1.84	-2.12
Cyclopentane	C <sub>5</sub> H <sub>10</sub>	-59.18	-1.36	-1.50	-1.55	-1.70
Cyclopropane	C <sub>3</sub> H <sub>6</sub>	-39.90	-0.81	-0.89	-0.92	-1.05
Diacetylene	C <sub>4</sub> H <sub>2</sub>	-37.50	-0.74	-0.81	-0.84	-0.96
Dichloroethylene	(CHCl) <sub>2</sub>	-49.20	-1.07	-1.18	-1.22	-1.40
Diethyl ether	(C <sub>2</sub> H <sub>5</sub> ) <sub>2</sub> O	-55.10	-1.25	-1.37	-1.41	-1.63
2,2 Difluoro 1 chloroethane	CClH <sub>2</sub> CHF <sub>2</sub>	-52.40	-1.17	-1.29	-1.33	-1.52
1,2 Difluoro 1,2 dichloroethylene	CFCl=CFCl	-60.00	-1.39	-1.53	-1.58	-1.81
Difluoro dichloro methane (Freon 12)	CCl <sub>2</sub> F <sub>2</sub>	-52.20	-1.16	-1.28	-1.32	-1.50
Dimethoxy methane	CH <sub>2</sub> (OCH <sub>3</sub> ) <sub>2</sub>	-47.30	-1.02	-1.12	1.16	-1.33
Dimethylamine	(CH <sub>3</sub> ) <sub>2</sub> NH	-39.90	-0.81	-0.89	-0.92	-1.05
Dimethylether	CH <sub>3</sub> OCH <sub>3</sub>	-26.30	-0.41	-0.46	-0.47	-0.54
Dimethylethylamine	(CH <sub>3</sub> ) <sub>2</sub> NC <sub>2</sub> H <sub>5</sub>	-63.60	-1.49	-1.64	-1.69	-1.95
Enflurane (Ethrane)	C <sub>3</sub> H <sub>2</sub> F <sub>5</sub> ClO	-80.10	-1.97	-2.17	-2.24	-2.57
Ethane	C <sub>2</sub> H <sub>6</sub>	-26.80	-0.43	-0.47	-0.49	-0.56
Ethanol	C <sub>2</sub> H <sub>5</sub> OH	-33.60	-0.62	-0.69	-0.71	-0.82
Ethyl acetate	CH <sub>3</sub> COOC <sub>2</sub> H <sub>5</sub>	-54.20	-1.22	-1.34	-1.39	-1.59
Ethyl amine	C <sub>2</sub> H <sub>5</sub> NH <sub>2</sub>	-39.90	-0.81	-0.89	-0.92	-1.05

Pure gas	Formula	Molar mag.susc  x 10 <sup>-6</sup>	Zero offset			
			20°C	50°C	60°C	110°C
Ethyl benzene	C <sub>6</sub> H <sub>5</sub> C <sub>2</sub> H <sub>5</sub>	-77.20	-1.88	-2.08	-2.14	-2.46
Ethyl bromide	C <sub>2</sub> H <sub>5</sub> Br	-54.70	-1.23	-1.36	-1.40	-1.61
Ethyl chloride	C <sub>2</sub> H <sub>5</sub> Cl	-46.00	-0.98	-1.08	-1.12	-1.28
Ethylene	C <sub>2</sub> H <sub>4</sub>	-18.80	-0.20	-0.22	-0.22	-0.26
Ethylene glycol	(CH <sub>2</sub> OH) <sub>2</sub>	-38.80	-0.77	-0.85	-0.88	-1.01
Ethylene oxide	(CH <sub>2</sub> ) <sub>2</sub> O	-30.70	-0.54	-0.60	-0.61	-0.71
Ethyl mercaptan	C <sub>2</sub> H <sub>5</sub> OSO <sub>3</sub> H	-47.00	-1.01	-1.11	-1.15	-1.32
Fluorochlorobromomethane	CFClBr	-58.00	-1.33	-1.46	-1.51	-1.74
Fluorodichloromethane (Freon 21)	CHCl <sub>2</sub> F	-48.80	-1.06	-1.17	-1.21	-1.39
Fluorene	CF <sub>3</sub> CH <sub>2</sub> OCHCH <sub>2</sub>	-56.70	-1.29	-1.42	-1.47	-1.69
Freon 114	C <sub>2</sub> Cl <sub>2</sub> F <sub>4</sub>	-77.40	-1.89	-2.08	-2.15	-2.47
Furan	C <sub>4</sub> H <sub>4</sub> O	-43.09	-0.90	-0.99	-1.02	-1.17
Germanium tetrachloride	GeCl <sub>4</sub>	-72.00	-1.73	-1.91	-1.97	-2.26
Halothane	C <sub>2</sub> HBrClF <sub>3</sub>	-78.80	-1.93	-2.13	-2.19	-2.52
Helium	He	-1.88	0.29	0.32	0.33	0.38
N-Heptane	C <sub>7</sub> H <sub>16</sub>	-85.24	-2.12	-2.33	-2.40	-2.76
N-Hexane	C <sub>6</sub> H <sub>14</sub>	-73.60	-1.78	-1.96	-2.02	-2.32
Hydrogen	H <sub>2</sub>	-3.98	0.23	0.26	0.26	0.30
Hydrogen bromide	Br	-35.30	-0.67	-0.74	-0.76	-0.88
Hydrogen chloride	HCl	-22.60	-0.31	-0.34	-0.35	-0.40
Hydrogen cyanide	HCN	-14.50	-0.07	-0.08	-0.08	-0.09
Hydrogen iodide	HI	-48.20	-1.05	-1.15	-1.19	-1.37
Hydrogen selenide	H <sub>2</sub> Se	-39.20	-0.79	-0.87	-0.89	-1.03

Pure gas	Formula	Molar mag.susc  x 10 <sup>-6</sup>	Zero offset			
			20°C	50°C	60°C	110°C
Hydrogen sulphide	H <sub>2</sub> S	-25.50	-0.39	-0.43	-0.44	-0.51
Isoflurane (Forane)	C <sub>3</sub> H <sub>2</sub> F <sub>5</sub> ClO	-80.10	-1.97	-2.17	-2.24	-2.57
Isoprene	C <sub>5</sub> H <sub>8</sub>	-44.80	-0.95	-1.04	-1.08	-1.24
Ketene	CH <sub>2</sub> CO	-15.70	-0.11	-0.12	-0.12	-0.14
Krypton	Kr	-28.80	-0.49	-0.54	-0.55	-0.63
Methane	CH <sub>4</sub>	-17.40	-0.16	-0.17	-0.18	-0.20
Methanol	CH <sub>3</sub> OH	-21.40	-0.27	-0.30	-0.31	-0.35
Methoxyfluorane	CHCl <sub>2</sub> CF <sub>2</sub> OCH <sub>3</sub>	-87.10	-2.17	-2.39	-2.47	-2.83
Methyl acetate	CH <sub>3</sub> COCH <sub>3</sub>	-42.60	-0.88	-0.97	-1.00	-1.15
Methyl cyclopentane	C <sub>6</sub> H <sub>12</sub>	-70.20	-1.68	-1.85	-1.91	-2.20
Methylene chloride	CH <sub>2</sub> Cl <sub>2</sub>	-46.60	-1.00	-1.10	-1.14	-1.31
Methylethylketone	CH <sub>3</sub> COCH <sub>2</sub> CH <sub>3</sub>	-45.50	-0.97	-1.07	-1.10	-1.26
Methyl fluoride	CH <sub>3</sub> F	-25.50	-0.39	-0.43	-0.44	-0.51
Methyl formate	HCOOCH <sub>3</sub>	-32.00	-0.58	-0.64	-0.66	-0.75
Methyl iodide	CH <sub>3</sub> I	-57.20	-1.31	-1.44	-1.48	-1.71
Methyl iso-butyl ketone (MIBK)	C <sub>4</sub> H <sub>9</sub> COCH <sub>3</sub>	-69.30	-1.66	-1.82	-1.88	-2.16
Methyl mercaptan	CH <sub>3</sub> SH	-35.30	-0.67	-0.74	-0.76	-0.88
Molybdenum hexafluoride	MoF <sub>6</sub>	-26.00	-0.40	-0.45	-0.46	-0.53
Monochlorobenzene	C <sub>6</sub> H <sub>5</sub> Cl	-70.00	-1.68	-1.85	-1.90	-2.19
Neon	Ne	-6.70	0.15	0.17	0.17	0.20
Nitric oxide	NO	1461.00	42.56	42.96	42.94	41.62
Nitrobenzene	C <sub>6</sub> H <sub>5</sub> NO <sub>2</sub>	-61.80	-1.44	-1.59	-1.63	-1.88
Nitrogen	N <sub>2</sub>	-12.00	0.00	0.00	0.00	0.00

Pure gas	Formula	Molar mag.susc  x 10 <sup>-6</sup>	Zero offset			
			20°C	50°C	60°C	110°C
Nitrogen dioxide	NO <sub>2</sub>	150.00	5.00	16.00	20.00	35.00
Ortho-Nitrotoluene	C <sub>6</sub> H <sub>4</sub> CH <sub>3</sub> NO <sub>2</sub>	-72.30	-1.74	-1.92	-1.98	-2.28
para-Nitrotoluene	C <sub>6</sub> H <sub>4</sub> CH <sub>3</sub> NO <sub>2</sub>	-76.90	-1.88	-2.07	-2.13	-2.45
Nitrous oxide	N <sub>2</sub> O	-18.90	-0.20	-0.22	-0.23	-0.26
N-Nonane	C <sub>9</sub> H <sub>20</sub>	-108.13	-2.78	-3.06	-3.16	-3.63
N-Octane	C <sub>8</sub> H <sub>18</sub>	-96.63	-2.45	-2.70	-2.78	-3.19
Oxygen	O <sub>2</sub>	3449.00	100.00	100.00	100.00	100.00
Ozone	O <sub>3</sub>	6.70	0.54	0.60	0.61	0.71
iso-Pentane	C <sub>5</sub> H <sub>12</sub>	-64.40	-1.51	-1.67	-1.72	-1.98
N-Pentane	C <sub>5</sub> H <sub>12</sub>	-63.10	-1.48	-1.63	-1.68	-1.93
0.01%Phenol	C <sub>6</sub> H <sub>5</sub> OH	-60.21	-1.39	-1.54	-1.58	-1.82
Phosphine	PH <sub>3</sub>	-26.00	-0.40	-0.45	-0.46	-0.53
Phosphorous oxychloride	POCl <sub>3</sub>	-69.00	-1.65	-1.82	-1.87	-2.15
Propane	C <sub>3</sub> H <sub>8</sub>	-38.60	-0.77	-0.85	-0.87	-1.00
iso-Propanol	(CH <sub>3</sub> ) <sub>2</sub> CHOH	-47.60	-1.03	-1.13	-1.17	-1.34
Propene	CH <sub>3</sub> CH=CH <sub>2</sub>	-31.50	-0.56	-0.62	-0.64	-0.74
N-Propyl acetate	CH <sub>3</sub> COOC <sub>3</sub> H <sub>7</sub>	-65.90	-1.56	-1.72	-1.77	-2.03
Propyl amine	C <sub>3</sub> H <sub>7</sub> NH <sub>2</sub>	-52.40	-1.17	-1.29	-1.33	-1.52
Propyl chloride	C <sub>3</sub> H <sub>7</sub> Cl	-56.10	-1.27	-1.40	-1.45	-1.66
Propylene	C <sub>3</sub> H <sub>6</sub>	-31.50	-0.56	-0.62	-0.64	-0.74
Propylene oxide	OCH <sub>2</sub> CHCH <sub>3</sub>	-42.50	-0.88	-0.97	-1.00	-1.15
iso-Propyl ether	(CH <sub>3</sub> ) <sub>4</sub> CHOCH	-79.40	-1.95	-2.15	-2.21	-2.54
Propyl fluoride	C <sub>3</sub> H <sub>7</sub> F	-52.20	-1.16	-1.28	-1.32	-1.52
Pyridine	N(CH) <sub>5</sub>	-49.21	-1.08	-1.19	-1.22	-1.40



Pure gas	Formula	Molar mag.susc  x 10 <sup>-6</sup>	Zero offset			
			20°C	50°C	60°C	110°C
Silane	SiH <sub>4</sub>	-20.50	-0.25	-0.27	-0.28	-0.32
Silicon tetrachloride	SiCl <sub>4</sub>	-88.30	-2.20	-2.43	-2.50	-2.88
Styrene	C <sub>6</sub> H <sub>5</sub> CH=CH <sub>2</sub>	-68.20	-1.62	-1.79	-1.85	-2.12
Sulphur dioxide	SO <sub>2</sub>	-18.20	-0.18	-0.20	-0.20	-0.23
Sulphur hexafluoride	SF <sub>6</sub>	-44.00	-0.92	-1.02	-1.05	-1.21
Tetrachoroethylene	Cl <sub>2</sub> C=CCl <sub>2</sub>	-81.60	-2.01	-2.22	-2.28	-2.63
Tetrahydrofuran	C <sub>4</sub> H <sub>8</sub> O	-52.00	-1.16	-1.27	-1.31	-1.51
Toluene	C <sub>6</sub> H <sub>5</sub> CH <sub>3</sub>	-66.11	-1.56	-1.72	-1.78	-2.04
1,1,2 Trichloroethane (Freon 113)	CHCl <sub>2</sub> CH <sub>2</sub> Cl	-66.20	-1.57	-1.73	-1.78	-2.05
Trichloroethylene	CHCl=CCl <sub>2</sub>	-65.80	-1.55	-1.71	-1.77	-2.03
Trifluorochloroethylene	C <sub>2</sub> F <sub>3</sub> Cl	-49.10	-1.07	-1.18	-1.22	-1.40
Trimethylamine	(CH <sub>3</sub> ) <sub>3</sub> N	-51.70	-1.15	-1.26	-1.30	-1.50
Tungsten fluoride	WF <sub>6</sub>	-40.00	-0.81	-0.89	-0.92	-1.06
Urethane	CO(NH <sub>2</sub> )OC <sub>2</sub> H <sub>5</sub>	-57.00	-1.30	-1.43	-1.48	-1.70
Vacuum	-	0.00	0.35	0.38	0.39	0.45
Vinyl bromide	CH <sub>2</sub> =CHBr	-44.80	-0.95	-1.04	-1.08	-1.24
Vinyl chloride	CH <sub>2</sub> =CHCl	-35.60	-0.68	-0.75	-0.77	-0.89
Vinyl fluoride	CH <sub>2</sub> =CHF	-28.80	-0.49	-0.54	-0.55	-0.63
Water	H <sub>2</sub> O	-13.00	-0.03	-0.03	-0.03	-0.04
Xenon	Xe	-43.90	-0.92	-1.02	-1.05	-1.20
Xylene	(CH <sub>3</sub> ) <sub>2</sub> C <sub>6</sub> H <sub>4</sub>	-77.78	-1.90	-2.09	-2.16	-2.48

This page intentionally blank.

## Appendix E MATERIALS IN CONTACT WITH SAMPLE AND CALIBRATION GASES

The materials of the parts of the analyser in contact with the sample and calibration gases are listed below. These materials have a wide range of chemical compatibility and corrosion resistance.

---

### Analyser with standard transducer:

---

304 Stainless Steel Viton

---

Viton

---

Borosilicate glass\*

---

316 stainless steel

---

Platinum

---

Platinum / Iridium Alloy

---

Electroless Nickel

---

### Analyser with solvent resistant transducer:

---

304 Stainless Steel

---

Chemraz® 555

---

PTFE

---

Borosilicate glass\*

---

316 stainless steel

---

Platinum

---

Platinum / Iridium Alloy

---

Electroless Nickel

---

### Pressure Sensor (Extra to above):

---

None

---

### Flowcube Flow Sensor (Extra to above):

---

Zirconia

---

Alumina Silicate Glass

---

This page intentionally blank.

## **Appendix F    DISPOSAL IN ACCORDANCE WITH THE WASTE ELECTRICAL AND ELECTRONIC EQUIPMENT (WEEE) DIRECTIVE**

The analyser is not considered to be within the scope of the Waste Electrical and Electronic Equipment (WEEE) Directive.

The analyser is not intended for disposal in a municipal waste stream but shall be submitted for material recovery and recycling in accordance with any appropriate local regulations.

For additional information and advice on the disposal of the analyser, contact Servomex:

Servomex Group Limited,  
Jarvis Brook,  
Crowborough,  
East Sussex,  
TN6 3FB,  
England

Tel: (+44) 1892 652181  
Fax: (+44) 1892 662253  
Global email: [info@servomex.com](mailto:info@servomex.com)

If you send the analyser to Servomex or your local Servomex agent for disposal, it must be accompanied by a correctly completed decontamination certificate.

This page intentionally blank.

## Appendix G COMPLIANCE AND STANDARDS INFORMATION

- The analyser complies with the European Community "Electromagnetic Compatibility Directive".
  - To comply with the above directive, the analyser must not be used in residential areas.
- The analyser complies with the European Community "ATEX Directive".
- The analyser is rated in accordance to Overvoltage Category II, Pollution Degree 2.
- The analyser complies with the Class A digital apparatus requirements of ICES-003 of Canada through the application of EN 55011:2007.
- L'analyseur est conforme aux Conditions A numériques d'appareillage de classe de NMB-003 du Canada par l'application du EN 55011:2007.
- This analyser complies with Part 15 of the US FCC Rules for Class A equipment. It is not suitable for operation when connected to a public utility power supply that also supplies residential environments.