

NACHI



## 止推滾珠軸承

精度..... 46頁

## ● 特點

- [1] 只可承受單向的軸向負荷。  
複式止推滾珠軸承可以承受雙向的軸向負荷。
- [2] 不能承受徑向負荷。
- [3] 調心座型止推滾珠軸承可以修正安裝誤差。
- [4] 使用聚酰胺保持器的軸承在包裝標識的公稱號碼末尾帶尾碼“G”。

## ● 公稱號碼

軸承上只在軸承座軌道盤和中央軌道盤上標示公稱號碼的後三位數。另外，軸軌道盤上不標示公稱號碼。

## ● 使用注意事項

- [1] 不允許軸有傾斜。
- [2] 不適合高速運轉。
- [3] 軌道盤或中央軌道盤的外徑部必須設置間隙。  
(參照圖1)  
但是，如果軸軌道盤或中央軌道盤外徑尺寸比座軌道盤外徑小(如表2所示)，則外徑部可以不設置間隙。(參照圖2)
- [4] 聚酰胺保持器應在低於120°C的溫度下使用。

表1. 止推滾珠軸承的軸承系列

類型	平面座形	調心座形	帶調心底環
單式	511	—	—
	512	532	532U
	513	533	533U
	514	534	534U
	29	—	—
	39	—	—
	O <sup>(1)</sup>	—	—
	TAM <sup>(2)</sup>	—	—
複式	522	542	542U
	523	543	543U
	524	544	544U

註(1) O系列是英制系列軸承。

(2) TAM形、TG形是小型和微型止推滾珠軸承。

表2.

軸承系列	內徑號碼
511	28~
512, 522, 532, 542	26~
513, 523, 533, 543	22~
514, 524, 534, 544	17~



圖1



圖2

### ● 標準保持器

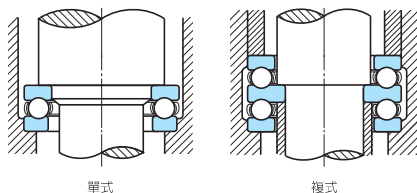
各軸承的標準保持器如表3所示。另外，如果需要使用其他標準保持器的軸承請與NACHI聯繫。

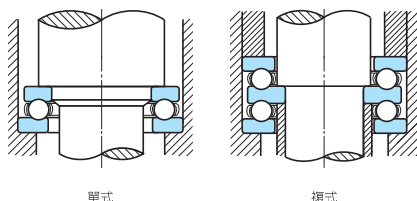

圖3. 聚酰胺保持器



圖4. 沖壓保持器

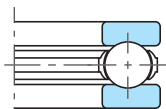

圖5. 車削保持器

表3. 止推滾珠軸承的標準保持器

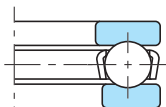
軸承系列	內 徑 號 碼		
	聚酰胺保持器	沖壓保持器	車削保持器
511	00~07	08~52	56~72
512	01~07	00, 08~28	30~72
513	—	05~20	22~40
514	—	05~14	15~36
522	02~07	00, 08~28	30~44
523	—	05~20	22~40
524	—	05~14	15~36
532	01~07	00, 08~28	30~72
533	—	05~20	22~40
534	—	05~14	15~36
542	02~07	08~28	30~44
543	—	05~20	22~24
544	—	05~14	15~20
29	—	00~22	23~28
39	—	05~24	—
O	—	3~30	32~48
TAM	—	3~8 <sup>(1)</sup>	—
TG	—	5~8 <sup>(1)</sup>	—

備註 尺寸表中所示的基本額定負荷為使用標準保持器時的負荷。因此，保持器形式不一樣時，額定負荷可能與尺寸表記載的資料不同。

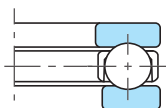
註(1) 標示的為內徑尺寸非內徑號碼。

### ● 最小軸向負荷

當止推滾珠軸承在較高速度下運轉時，受鋼球離心力的作用，鋼球和軌道的接觸角發生變化，從而在兩者之間引起滑動（迴旋活動）。

該滑動可能會造成軌道面出現微小的燒結（汙斑）和啃傷等損傷。因此，為防止這種滑動的產生，必須在軸承上施加按公式(1)、公式(2)求出的從最小到最大的軸向複負荷。

止推軸承只能承受一個方向的軸向負荷，所以，如果有兩個方向的軸向負荷的作用，必須選用複式軸承或者在2個軸承之間用彈簧等施加預壓。

如果是垂直軸，因軸的自重等原因初始軸向負荷通常超過該最小軸向負荷。但是，需要注意的是，由於運轉中反方向的軸向負荷的作用，即使在此時仍有可能低於最小軸向負荷。

$$F_{a \min} = K \cdot n^2 \dots \dots \dots (1)$$

$$F_{a \min} = \frac{C_{oa}}{1000} \dots \dots \dots (2)$$

取公式(1)和公式(2)計算值中較大的值。

式中

$F_{a \min}$ : 最小軸向負荷 (N)

K: 最小軸向負荷係數 (表4)

n: 軸承的轉速 ( $\text{min}^{-1}$ )

$C_{oa}$ : 基本額定靜負荷 (N)

表4. 止推滾珠軸承的最小徑向負荷係數K ( $\times 10^{-6}$ )

系列 内徑號碼	系列				系列 内徑號碼	系列		系列 内徑號碼	
	511	512, 522	513, 523	514, 524		29	39		0
00	1.03	1.55	—	—	00	1.55	—	3	1.34
01	1.26	1.92	—	—	01	1.92	—	4	3.62
02	1.56	3.36	—	—	02	2.64	—	5	4.65
03	1.84	4.09	—	—	03	3.30	—	6	6.40
04	3.42	7.33	—	—	04	3.82	—	7	7.76
05	7.19	13.1	20.4	43.8	04 1/2	6.41	—	8	9.24
06	9.36	17.2	33.1	81.4	05	7.51	14.2	9	11.6
07	11.2	32.8	58.3	128	06	9.72	28.9	10	16.5
08	20.4	49.7	97.2	221	07	20.1	52.3	11	19.0
09	24.6	57.9	138	316	08	25.1	81.0	12	23.0
10	29.3	66.8	211	440	09	31.6	140	13	21.0
11	44.6	133	326	656	10	46.1	209	14	31.3
12	64.7	160	375	956	11	54.4	284	15	42.1
13	72.0	179	428	1240	12	60.7	350	16	46.9
14	82.8	200	596	1580	13	86.0	426	17	75.0
15	94.3	222	808	1800	14	99.5	556	18	82.8
16	103	245	907	2230	15	114	704	19	110
17	116	359	1240	2740	16	152	927	20	121
18	187	528	1390	4320	17	172	1210	21	132
20	363	850	1850	4790	18	187	1580	22	176
22	423	1010	2740	8220	19	286	2010	23	204
24	488	1130	4130	9980	20	321	2090	24	223
26	648	1940	5140	16100	21	346	2390	26	350
28	782	2150	6330	16900	22	361	3220	28	395
30	886	2490	7140	25800	23	350	3940	30	431
32	997	2880	9960	30000	24	538	4500	32	580
34	1420	3940	11100	40100	25	498	—	36	1100
36	1540	4330	15800	46330	26	—	—	40	1730
38	2340	6290	23100	—	27	—	—	44	2840
40	2520	6880	29700	—	28	794	—	48	3690
44	3000	8130	—	—					
48	4900	15900	—	—					
52	5580	18400	—	—					
56	9800	20400	—	—					
60	14600	38000	—	—					
64	16400	41800	—	—					
68	18300	45700	—	—					
72	20300	75600	—	—					

# ■ 單式止推滾珠軸承

內徑: 10~50mm

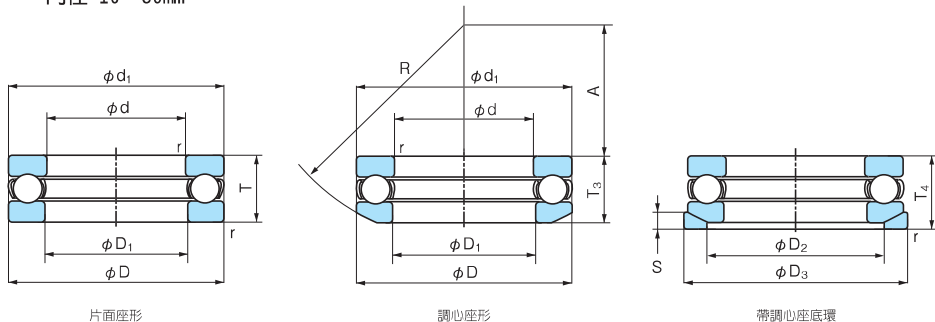

片面座形

調心座形

帶調心底座環

1N=0.102kgf

主要尺寸 (mm)						公稱號碼			基本額定動 負荷 Ca(N)	基本額定靜 負荷 Coa(N)	極限轉速 (min <sup>-1</sup> )	
d	D	T	T <sub>3</sub>	T <sub>4</sub>	r (最小)	平面座形	調心座形	帶調心座 底環			潤滑脂 潤滑	油潤滑
10	24	9	—	—	0.3	51100	—	—	10000	14000	6800	10000
	26	11	11.6	13	0.6	51200	53200	53200U	12700	17100	5900	8800
12	26	9	—	—	0.3	51101	—	—	10300	15400	6500	9800
	28	11	11.4	13	0.6	51201	53201	53201U	13200	19000	5600	8500
15	28	9	—	—	0.3	51102	—	—	10500	16800	6200	9400
	32	12	13.3	15	0.6	51202	53202	53202U	16600	24800	5100	7600
17	30	9	—	—	0.3	51103	—	—	10800	18200	6000	9100
	35	12	13.2	15	0.6	51203	53203	53203U	17100	27300	4800	7300
20	35	10	—	—	0.3	51104	—	—	14300	24700	5300	8000
	40	14	14.7	17	0.6	51204	53204	53204U	22200	37500	4200	6300
25	42	11	—	—	0.6	51105	—	—	19500	37000	4600	6900
	47	15	16.7	19	0.6	51205	53205	53205U	27800	50500	3700	5600
	52	18	19.8	22	1	51305	53305	53305U	35500	61500	3200	4900
	60	24	26.4	29	1	51405	53405	53405U	55500	89500	2600	3900
30	47	11	—	—	0.6	51106	—	—	20400	42000	4300	6500
	52	16	17.8	20	0.6	51206	53206	53206U	29300	58000	3400	5200
	60	21	22.6	25	1	51306	53306	53306U	42500	78500	2800	4200
35	70	28	30.1	33	1	51406	53406	53406U	72500	126000	2200	3300
	52	12	—	—	0.6	51107	—	—	20400	44500	4000	6000
	62	18	19.9	22	1	51207	53207	53207U	39000	78000	2900	4400
	68	24	25.6	28	1	51307	53307	53307U	55500	105000	2400	3700
40	80	32	34	37	1.1	51407	53407	53407U	87000	155000	1900	2900
	60	13	—	—	0.6	51108	—	—	26900	63000	3500	5300
	68	19	20.3	23	1	51208	53208	53208U	47000	98500	2700	4100
	78	26	28.5	31	1	51308	53308	53308U	69000	135000	2200	3300
45	90	36	38.2	42	1.1	51408	53408	53408U	112000	205000	1700	2600
	65	14	—	—	0.6	51109	—	—	27800	69000	3300	4900
	73	20	21.3	24	1	51209	53209	53209U	47500	105000	2600	3900
	85	28	30.1	33	1	51309	53309	53309U	80000	163000	2000	3000
50	100	39	42.4	46	1.1	51409	53409	53409U	129000	243000	1600	2400
	70	14	—	—	0.6	51110	—	—	28800	75500	3100	4700
	78	22	23.5	26	1	51210	53210	53210U	48500	112000	2400	3600
	95	31	34.3	37	1.1	51310	53310	53310U	96500	202000	1800	2700
110	43	45.6	50	1.5	51410	53410	53410U	148000	283000	1400	2100	

RA

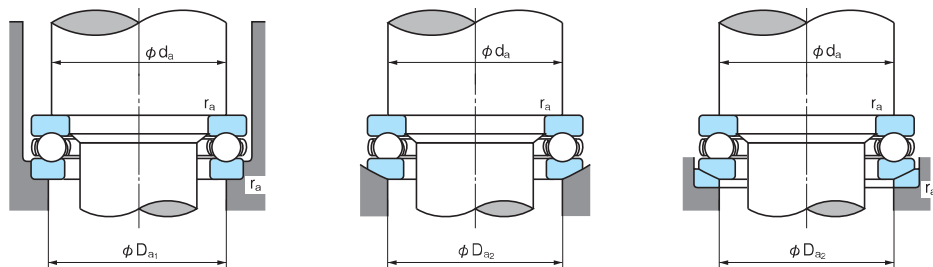

	主要尺寸 (mm)							安裝尺寸 (mm)				參考重量 (kg)			公稱號碼
	$D_1$ (最小)	$d_1$ (最大)	$D_2$	$D_3$	S	R	A	$d_a$ (最小)	$D_{a1}$ (最大)	$D_{a2}$ (最大)	$r_a$ (最大)	平面 座形	調心 座形	帶調心 座底環	
	11	24	—	—	—	—	—	18	16	—	0.3	0.020	—	—	<b>51100</b>
	12	26	18	28	3.5	22	8.5	20	16	18	0.6	0.030	0.029	0.036	<b>51200</b>
	13	26	—	—	—	—	—	20	18	—	0.3	0.022	—	—	<b>51101</b>
	14	28	20	30	3.5	25	11.5	22	18	20	0.6	0.034	0.033	0.041	<b>51201</b>
	16	28	—	—	—	—	—	23	20	—	0.3	0.024	—	—	<b>51102</b>
	17	32	24	35	4	28	12	25	22	24	0.6	0.046	0.048	0.061	<b>51202</b>
	18	30	—	—	—	—	—	25	22	—	0.3	0.028	—	—	<b>51103</b>
	19	35	26	38	4	32	16	28	24	26	0.6	0.053	0.055	0.070	<b>51203</b>
	21	35	—	—	—	—	—	29	26	—	0.3	0.040	—	—	<b>51104</b>
	22	40	30	42	5	36	18	32	28	30	0.6	0.082	0.080	0.100	<b>51204</b>
	26	42	—	—	—	—	—	35	32	—	0.6	0.059	—	—	<b>51105</b>
	27	47	36	50	5.5	40	19	38	34	36	0.6	0.120	0.125	0.160	<b>51205</b>
	27	52	38	55	6	45	21	41	36	38	1	0.180	0.185	0.225	<b>51305</b>
	27	60	42	62	8	50	19	46	39	42	1	0.340	0.350	0.420	<b>51405</b>
	32	47	—	—	—	—	—	40	37	—	0.6	0.068	—	—	<b>51106</b>
	32	52	42	55	5.5	45	22	43	39	42	0.6	0.150	0.160	0.195	<b>51206</b>
	32	60	45	62	7	50	22	48	42	45	1	0.270	0.270	0.325	<b>51306</b>
	32	70	50	75	9	56	20	54	46	50	1	0.530	0.530	0.680	<b>51406</b>
	37	52	—	—	—	—	—	45	42	—	0.6	0.085	—	—	<b>51107</b>
	37	62	48	65	7	50	24	51	46	48	1	0.220	0.220	0.290	<b>51207</b>
	37	68	52	72	7.5	56	24	55	48	52	1	0.390	0.390	0.475	<b>51307</b>
	37	80	58	85	10	64	23	62	53	58	1	0.790	0.790	0.950	<b>51407</b>
	42	60	—	—	—	—	—	52	48	—	0.6	0.120	—	—	<b>51108</b>
	42	68	55	72	7	56	28.5	57	51	55	1	0.270	0.270	0.340	<b>51208</b>
	42	78	60	82	8.5	64	28	63	55	60	1	0.550	0.570	0.690	<b>51308</b>
	42	90	65	95	12	72	26	70	60	65	1	1.14	1.13	1.38	<b>51408</b>
	47	65	—	—	—	—	—	57	53	—	0.6	0.150	—	—	<b>51109</b>
	47	73	60	78	7.5	56	26	62	56	60	1	0.320	0.320	0.410	<b>51209</b>
	47	85	65	90	10	64	25	69	61	65	1	0.690	0.680	0.850	<b>51309</b>
	47	100	72	105	12.5	80	29	78	67	72	1	1.47	1.50	1.80	<b>51409</b>
	52	70	—	—	—	—	—	62	58	—	0.6	0.160	—	—	<b>51110</b>
	52	78	62	82	7.5	64	32.5	67	61	62	1	0.390	0.380	0.480	<b>51210</b>
	52	95	72	100	11	72	28	77	68	72	1	1.00	1.00	1.25	<b>51310</b>
	52	110	80	115	14	90	35	86	74	80	1.5	1.99	1.97	2.40	<b>51410</b>

FOR

# ■ 單式止推滾珠軸承

內徑: 55~100mm

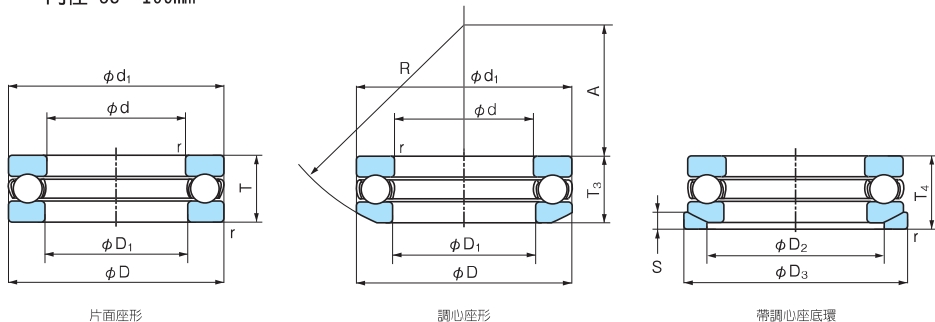

片面座形

調心座形

帶調心底環

1N=0.102kgf

主要尺寸 (mm)						公稱號碼			基本額定動 負荷 Ca(N)	基本額定靜 負荷 C0a(N)	極限轉速 (min <sup>-1</sup> )	
d	D	T	T <sub>3</sub>	T <sub>4</sub>	r (最小)	片面座形	調心座形	帶調心底環			潤滑脂 潤滑	油潤滑
55	78	16	—	—	0.6	51111	—	—	35000	93000	2800	4200
	90	25	27.3	30	1	51211	53211	53211U	69500	159000	2100	3100
	105	35	39.3	42	1.1	51311	53311	53311U	120000	246000	1600	2400
	120	48	50.5	55	1.5	51411	53411	53411U	178000	360000	1300	1900
60	85	17	—	—	1	51112	—	—	41500	113000	2600	3900
	95	26	28	31	1	51212	53212	53212U	73500	179000	2000	3000
	110	35	38.3	42	1.1	51312	53312	53312U	123000	267000	1600	2400
	130	51	54	58	1.5	51412	53412	53412U	213000	435000	1200	1800
65	90	18	—	—	1	51113	—	—	41500	117000	2400	3700
	100	27	28.7	32	1	51213	53213	53213U	75000	189000	1900	2800
	115	36	39.4	43	1.1	51313	53313	53313U	127000	287000	1500	2300
	140	56	60.2	65	2	51413	53413	53413U	231000	495000	1100	1600
70	95	18	—	—	1	51114	—	—	43000	127000	2400	3600
	105	27	28.8	32	1	51214	53214	53214U	76000	199000	1800	2800
	125	40	44.2	48	1.1	51314	53314	53314U	148000	340000	1400	2100
	150	60	63.6	69	2	51414	53414	53414U	250000	555000	1000	1500
75	100	19	—	—	1	51115	—	—	44500	136000	2200	3400
	110	27	28.3	32	1	51215	53215	53215U	77500	209000	1800	2700
	135	44	48.1	52	1.5	51315	53315	53315U	170000	395000	1200	1900
	160	65	69	75	2	51415	53415	53415U	252000	560000	950	1400
80	105	19	—	—	1	51116	—	—	44500	141000	2200	3300
	115	28	29.5	33	1	51216	53216	53216U	78500	219000	1700	2600
	140	44	47.6	52	1.5	51316	53316	53316U	176000	425000	1200	1800
	170	68	72.2	78	2.1	51416	53416	53416U	270000	620000	900	1300
85	110	19	—	—	1	51117	—	—	46000	150000	2100	3200
	125	31	33.1	37	1	51217	53217	53217U	95500	264000	1600	2400
	150	49	53.1	58	1.5	51317	53317	53317U	206000	490000	1100	1700
	180	72	77	83	2.1	51417	53417	53417U	288000	685000	850	1200
90	120	22	—	—	1	51118	—	—	59500	190000	1900	2900
	135	35	38.5	42	1.1	51218	53218	53218U	116000	325000	1400	2100
	155	50	54.6	59	1.5	51318	53318	53318U	213000	525000	1100	1600
	190	77	81.2	88	2.1	51418	53418	53418U	305000	750000	790	1100
100	135	25	—	—	1	51120	—	—	85000	268000	1700	2500
	150	38	40.9	45	1.1	51220	53220	53220U	146000	410000	1300	1900
	170	55	59.2	64	1.5	51320	53320	53320U	236000	595000	1000	1500
	210	85	90	98	3	51420	53420	53420U	345000	895000	710	1000

RR

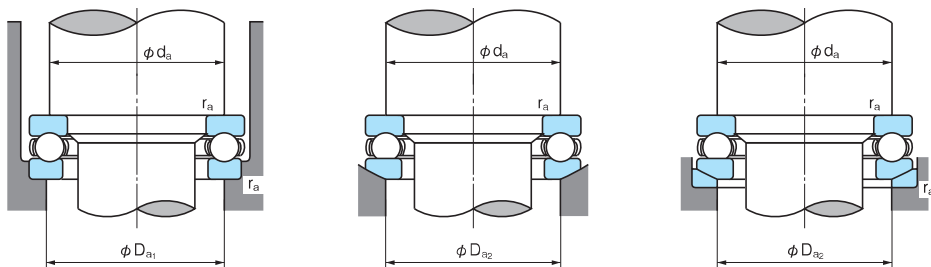

	主要尺寸 (mm)							安裝尺寸 (mm)				參考重量 (kg)			公稱號碼
	$D_1$ (最小)	$d_1$ (最大)	$D_2$	$D_3$	S	R	A	$d_a$ (最小)	$D_{a1}$ (最大)	$D_{a2}$ (最大)	$r_a$ (最大)	平面座形	調心座形	帶調心座底環	
57	78	—	—	—	—	—	—	69	64	—	0,6	0,240	—	—	51111
57	90	72	95	9	72	35	76	69	69	72	1	0,610	0,620	0,800	51211
57	105	80	110	11,5	80	30	85	75	80	80	1	1,34	1,40	1,70	51311
57	120	88	125	15,5	90	28	94	81	88	88	1,5	2,64	2,55	3,70	51411
62	85	—	—	—	—	—	75	70	—	—	1	0,290	—	—	51112
62	95	78	100	9	72	32,5	81	74	78	78	1	0,690	0,690	0,850	51212
62	110	85	115	11,5	90	41	90	80	85	85	1	1,43	1,45	1,75	51312
62	130	95	135	16	100	34	102	88	95	95	1,5	3,30	3,25	3,85	51412
67	90	—	—	—	—	—	80	75	—	—	1	0,340	—	—	51113
67	100	82	105	9	80	40	86	79	82	82	1	0,770	0,770	0,940	51213
67	115	90	120	12,5	90	38,5	95	85	90	90	1	1,57	1,60	1,95	51313
68	140	100	145	17,5	112	40	110	95	100	100	2	4,18	4,17	4,95	51413
72	95	—	—	—	—	—	85	80	—	—	1	0,360	—	—	51114
72	105	88	110	9	80	38	91	84	88	88	1	0,810	0,800	0,980	51214
72	125	98	130	13	100	43	103	92	98	98	1	2,06	2,15	2,55	51314
73	150	110	155	19,5	112	34	118	102	110	110	2	5,11	4,94	5,93	51414
77	100	—	—	—	—	—	90	85	—	—	1	0,420	—	—	51115
77	110	92	115	9,5	90	49	96	89	92	92	1	0,860	0,840	1,05	51215
77	135	105	140	15	100	37	111	99	105	105	1,5	2,68	2,70	3,25	51315
78	160	115	165	21	125	42	126	109	115	115	2	6,35	6,25	7,60	51415
82	105	—	—	—	—	—	95	90	—	—	1	0,430	—	—	51116
82	115	98	120	10	90	46	101	94	98	98	1	0,950	0,930	1,16	51216
82	140	110	145	15	112	50	116	104	110	110	1,5	2,82	2,85	3,45	51316
83	170	125	175	22	125	36	134	116	125	125	2	7,97	7,83	9,14	51416
87	110	—	—	—	—	—	100	95	—	—	1	0,460	—	—	51117
88	125	105	130	11	100	52	109	101	105	105	1	1,29	1,29	1,60	51217
88	150	115	155	17,5	112	43	124	111	115	115	1,5	3,66	3,65	4,45	51317
88	177	130	185	23	140	47	142	123	130	130	2	9,30	9,20	10,9	51417
92	120	—	—	—	—	—	108	102	—	—	1	0,680	—	—	51118
93	135	110	140	13,5	100	45	117	108	110	110	1	1,77	1,78	2,22	51218
93	155	120	160	18	112	40	129	116	120	120	1,5	3,88	3,84	4,70	51318
93	187	140	195	25,5	140	40	150	130	140	140	2	11,0	10,7	12,6	51418
102	135	—	—	—	—	—	121	114	—	—	1	0,990	—	—	51119
103	150	125	155	14	112	52	130	120	125	125	1	2,36	2,36	2,87	51220
103	170	135	175	18	125	46	142	128	135	135	1,5	5,11	5,12	6,10	51320
103	205	155	220	27	160	50	166	144	155	155	2,5	14,7	14,5	17,2	51420

FOR



# ■ 單式止推滾珠軸承

內徑: 110~190mm

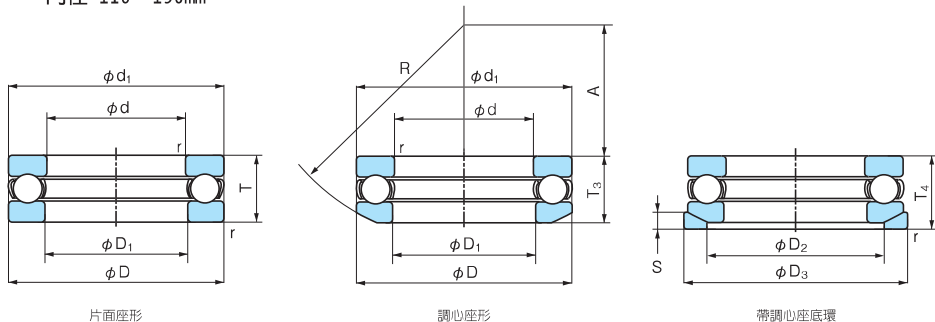

片面座形

調心座形

帶調心座底環

1N=0.102kgf

主要尺寸 (mm)						公稱號碼			基本額定動 負荷 Ca(N)	基本額定靜 負荷 C0a(N)	極限轉速 (min <sup>-1</sup> )	
d	D	T	T <sub>3</sub>	T <sub>4</sub>	r (最小)	平面座形	調心座形	帶調心座 底環			潤滑脂 潤滑	油潤滑
110	145	25	—	—	1	51122	—	—	87000	288000	1600	2400
	160	38	40.2	45	1.1	51222	53222	53222U	152000	450000	1200	1900
	190	63	67.2	72	2	51322	53322	53322U	267000	705000	880	1300
	230	95	99.7	109	3	51422	53422	53422U	435000	1240000	640	960
120	155	25	—	—	1	51124	—	—	89000	305000	1600	2400
	170	39	40.8	46	1.1	51224	53224	53224U	154000	470000	1200	1800
	210	70	74.1	80	2.1	51324	53324	53324U	310000	870000	790	1100
	250	102	107.3	118	4	51424	53424	53424U	455000	1340000	580	880
130	170	30	—	—	1	51126	—	—	104000	350000	1300	2000
	190	45	47.9	53	1.5	51226	53226	53226U	203000	620000	1000	1500
	225	75	80.3	86	2.1	51326	53326	53326U	330000	960000	730	1100
	270	110	115.2	128	4	51426	53426	53426U	555000	1750000	540	810
140	180	31	—	—	1	51128	—	—	107000	375000	1300	1900
	200	46	48.6	55	1.5	51228	53228	53228U	205000	650000	1000	1500
	240	80	84.9	92	2.1	51328	53328	53328U	350000	1050000	680	1000
	280	112	117	131	4	51428	53428	53428U	545000	1750000	520	780
150	190	31	—	—	1	51130	—	—	109000	400000	1200	1900
	215	50	53.3	60	1.5	51230	53230	53230U	213000	650000	940	1400
	250	80	83.7	92	2.1	51330	53330	53330U	360000	1130000	670	1000
	300	120	125.9	140	4	51430	53430	53430U	615000	2010000	480	720
160	200	31	—	—	1	51132	—	—	112000	425000	1200	1800
	225	51	54.7	61	1.5	51232	53232	53232U	223000	720000	900	1300
	270	87	91.7	100	3	51332	53332	53332U	410000	1340000	610	920
	320	130	135.3	150	5	51432	53432	53432U	680000	2410000	440	670
170	215	34	—	—	1.1	51134	—	—	134000	510000	1100	1700
	240	55	58.7	65	1.5	51234	53234	53234U	261000	835000	840	1200
	280	87	91.3	100	3	51334	53334	53334U	420000	1430000	600	900
	340	135	141	156	5	51434	53434	53434U	755000	2730000	420	630
180	225	34	—	—	1.1	51136	—	—	135000	525000	1100	1600
	250	56	58.2	66	1.5	51236	53236	53236U	266000	875000	810	1200
	300	95	99.3	109	3	51336	53336	53336U	485000	1700000	550	820
	360	140	148.3	164	5	51436	53436	53436U	785000	2980000	400	600
190	240	37	—	—	1.1	51138	—	—	170000	655000	1000	1500
	270	62	65.7	73	2	51238	53238	53238U	310000	1060000	740	1100
	320	105	111	121	4	51338	53338	53338U	570000	2100000	500	750

RA

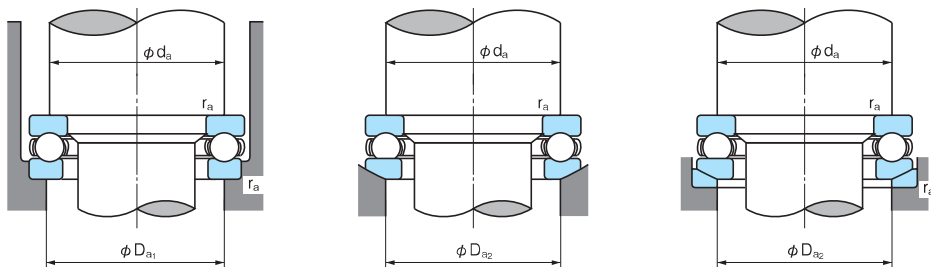

	主要尺寸 (mm)							安裝尺寸 (mm)				參考重量 (kg)			公稱號碼
	D <sub>1</sub> (最小)	d <sub>1</sub> (最大)	D <sub>2</sub>	D <sub>3</sub>	S	R	A	d <sub>a</sub> (最小)	D <sub>a1</sub> (最大)	D <sub>a2</sub> (最大)	r <sub>a</sub> (最大)	平面 座形	調心 座形	帶調心 座底環	
112	145	—	—	—	—	—	—	131	124	—	1	1.08	—	—	51122
113	160	135	165	14	125	65	140	130	135	1	2.57	2.53	3.00	51222	
113	187	150	195	20.5	140	51	158	142	150	2	7.73	7.66	8.96	51322	
113	225	170	240	29	180	59	182	158	170	2.5	19.8	19.4	22.9	51422	
122	155	—	—	—	—	—	—	141	134	—	1	1.16	—	—	51124
123	170	145	175	15	125	61	150	140	145	1	2.86	2.76	3.40	51224	
123	205	165	220	22	160	63	174	156	165	2	10.6	10.4	12.4	51324	
123	245	185	260	32	200	70	198	172	185	3	25.0	24.6	29.2	51424	
132	170	—	—	—	—	—	—	154	145	—	1	1.87	—	—	51126
133	187	160	195	17	140	67	166	154	160	1.5	4.10	4.03	4.91	51226	
134	220	177	235	26	160	53	187	168	177	2	12.7	12.6	15.2	51326	
134	265	200	280	38	200	58	214	186	200	3	31.4	30.4	36.7	51426	
142	178	—	—	—	—	—	—	164	156	—	1	2.03	—	—	51128
143	197	170	210	17	160	87	176	164	170	1.5	4.47	4.40	5.61	51228	
144	235	190	250	26	180	68	200	180	190	2	15.5	15.3	18.2	51328	
144	275	206	290	38	225	83	224	196	206	3	33.9	32.9	39.9	51428	
152	188	—	—	—	—	—	—	174	166	—	1	2.16	—	—	51130
153	212	180	225	20.5	160	79	189	176	180	1.5	5.74	5.60	7.28	51230	
154	245	200	260	26	200	89.5	210	190	200	2	16.3	16.0	19.1	51330	
154	295	225	310	41	225	69	240	210	225	3	41.6	40.5	48.5	51430	
162	198	—	—	—	—	—	—	184	176	—	1	2.27	—	—	51132
163	222	190	235	21	160	74	223	202	190	1.5	6.64	6.50	8.29	51232	
164	265	215	280	29	200	77	226	204	215	2.5	21.0	20.5	24.5	51332	
164	315	240	330	41.5	250	84	256	224	240	4	51.2	49.7	58.9	51432	
172	213	—	—	—	—	—	—	197	188	—	1	3.27	—	—	51134
173	237	200	250	21.5	180	91	212	198	200	1.5	8.13	7.89	9.95	51234	
174	275	220	290	29	225	105	230	210	220	2.5	22.0	21.3	25.7	51334	
174	335	255	350	46	250	74	272	238	255	4	60.1	58.1	69.1	51434	
183	222	—	—	—	—	—	—	207	198	—	1	3.37	—	—	51136
183	247	210	260	21.5	200	112	222	208	210	1.5	8.69	8.26	10.5	51236	
184	295	240	310	32	225	91	252	228	240	2.5	28.2	27.0	32.0	51336	
184	355	270	370	46.5	280	97	288	252	270	4	69.5	68.8	81.5	51436	
193	237	—	—	—	—	—	—	220	210	—	1	3.95	—	—	51138
194	267	230	280	23	200	98	238	222	230	2	11.7	11.5	14.0	51238	
195	315	255	330	33	250	104	268	242	255	3	36.1	35.8	41.9	51338	

FOR

# ■ 單式止推滾珠軸承

內徑：200~360mm

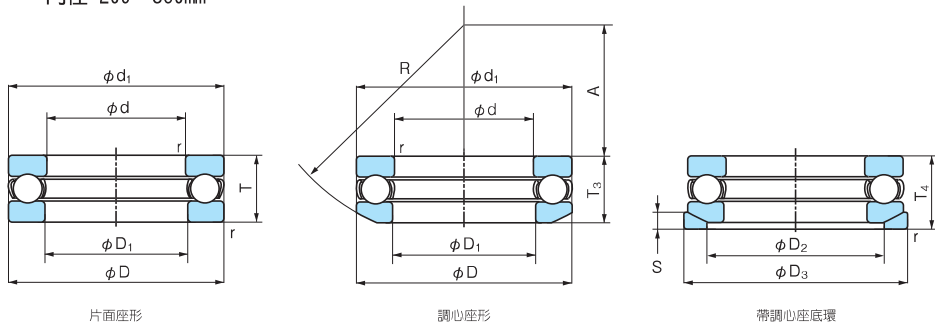

片面座形

調心座形

帶調心底座環

1N=0.102kgf

主要尺寸 (mm)						公稱號碼			基本額定動 負荷 Ca(N)	基本額定靜 負荷 Coa(N)	極限轉速 (min <sup>-1</sup> )	
d	D	T	T <sub>3</sub>	T <sub>4</sub>	r (最小)	平面座形	調心座形	帶調心座 底環			潤滑脂 潤滑	油潤滑
200	250	37	—	—	1.1	51140	—	—	172000	675000	1000	1500
	280	62	65.3	74	2	51240	53240	53240U	315000	1110000	720	1000
	340	110	118.4	130	4	51340	53340	53340U	625000	2380000	470	710
220	270	37	—	—	1.1	51144	—	—	177000	740000	970	1400
	300	63	65.6	75	2	51244	53244	53244U	325000	1210000	690	1000
240	300	45	—	—	1.5	51148	—	—	228000	935000	830	1200
	340	78	81.6	92	2.1	51248	53248	53248U	430000	1730000	570	860
260	320	45	—	—	1.5	51152	—	—	232000	990000	800	1200
	360	79	82.8	93	2.1	51252	53252	53252U	445000	1880000	550	830
280	350	53	—	—	1.5	51156	—	—	315000	1350000	700	1000
	380	80	85	94	2.1	51256	53256	53256U	450000	1950000	530	800
300	380	62	—	—	2	51160	—	—	370000	1660000	610	920
	420	95	100.5	112	3	51260	53260	53260U	585000	2720000	450	680
320	400	63	—	—	2	51164	—	—	380000	1760000	590	880
	440	95	100.5	112	3	51264	53264	53264U	595000	2830000	440	660
340	420	64	—	—	2	51168	—	—	385000	1860000	570	850
	460	96	100.3	113	3	51268	53268	53268U	600000	2940000	430	640
360	440	65	—	—	2	51172	—	—	395000	1960000	550	820
	500	110	116.7	130	4	51272	53272	53272U	745000	3800000	380	570

RR

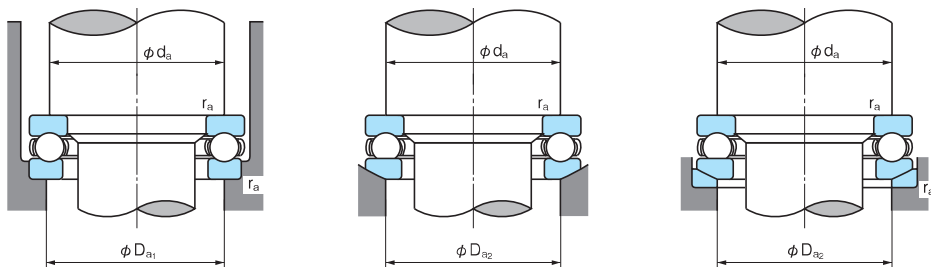

	主要尺寸 (mm)							安裝尺寸 (mm)				參考重量 (kg)			公稱號碼
	D <sub>1</sub> (最小)	d <sub>1</sub> (最大)	D <sub>2</sub>	D <sub>3</sub>	S	R	A	d <sub>a</sub> (最小)	D <sub>a1</sub> (最大)	D <sub>a2</sub> (最大)	r <sub>a</sub> (最大)	平面 座形	調心 座形	帶調心 座底環	
203	247	—	—	—	—	—	—	230	220	—	1	4.14	—	—	51140
204	277	240	290	23	225	125	248	232	240	2	12.2	12.0	14.8	51240	
205	335	270	350	38	250	92	284	256	270	3	43.0	43.1	51.0	51340	
223	267	—	—	—	—	—	250	240	—	1	4.51	—	—	51144	
224	297	260	310	25	225	118	268	252	260	2	13.5	13.0	16.2	51244	
243	297	—	—	—	—	—	276	264	—	1.5	7.35	—	—	51148	
244	335	290	350	30	250	122	300	280	290	2	23.1	22.3	27.4	51248	
263	317	—	—	—	—	—	296	284	—	1.5	7.94	—	—	51152	
264	355	305	370	30	280	152	320	300	305	2	25.0	24.0	29.7	51252	
283	347	—	—	—	—	—	322	308	—	1.5	12.0	—	—	51156	
284	375	325	390	31	280	143	340	320	325	2	27.0	26.2	32.3	51256	
304	376	—	—	—	—	—	348	332	—	2	17.1	—	—	51160	
304	415	360	430	34	320	164	372	348	360	2.5	42.3	41.7	49.9	51260	
324	396	—	—	—	—	—	368	352	—	2	18.5	—	—	51164	
325	435	380	450	36	320	157	392	368	380	2.5	44.7	43.8	52.7	51264	
344	416	—	—	—	—	—	388	372	—	2	19.9	—	—	51168	
345	455	400	470	36	360	199	412	388	400	2.5	47.6	46.4	56.2	51268	
364	436	—	—	—	—	—	408	392	—	2	20.4	—	—	51172	
365	495	430	510	43	360	172	444	416	430	3	69.0	67.7	81.5	51272	

FOR

■ 單式止推滾珠軸承

2900系列

內徑: 10~140mm

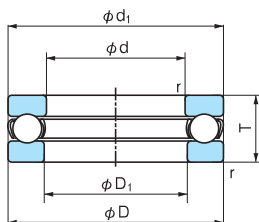

1N=0.102kgf

主要尺寸 (mm)				公稱號碼	基本 額定動 負荷 Ca(N)	基本 額定靜 負荷 Coa(N)	極限轉速 (min <sup>-1</sup> )		
d	D	T	r (最小)				潤滑劑潤滑	油潤滑	
10	26	12	0.6	2900	12700	17100	5600	8400	
12	28	12	0.6	2901	13200	19000	5400	8100	
15	31	12	0.6	2902	14300	22800	5100	7700	
18	35	12	0.6	2903	14400	24700	4800	7300	
20	37	12	0.6	2904	14800	26600	4700	7100	
22	42	14	0.6	2904 ½	18900	34500	4100	6100	
25	45	14	0.6	2905	19300	37000	3900	5900	
30	50	14	0.6	2906	20200	42000	3700	5600	
35	55	16	0.6	2907	29900	62000	3300	5000	
40	60	16	0.6	2908	31000	70000	3200	4800	
45	68	16	0.6	2909	32500	77500	3000	4500	
50	74	18	0.6	2910	38500	94000	2700	4100	
55	78	18	0.6	2911	40000	103000	2600	4000	
60	82	18	0.6	2912	40500	108000	2600	3900	
65	90	20	0.6	2913	47500	129000	2300	3500	
70	95	20	0.6	2914	49000	140000	2200	3400	
75	100	20	0.6	2915	51000	151000	2200	3300	
80	110	22	0.6	2916	57000	171000	2000	3000	
85	115	22	0.6	2917	59000	184000	1900	2900	
90	120	22	0.6	2918	59500	190000	1900	2900	
95	130	25	0.6	2919	75500	236000	1700	2600	
100	135	25	0.6	2920	78000	253000	1700	2500	
105	140	25	0.6	2921	78500	262000	1600	2500	
110	145	25	0.6	2922	78000	262000	1600	2400	
115	150	25	0.6	2923	73500	245000	1600	2400	
120	160	27	0.6	2924	94000	314000	1500	2200	
125	165	27	0.6	2925	85500	298000	1400	2200	
140	185	31	0.6	2928	106000	375000	1300	1900	

RA

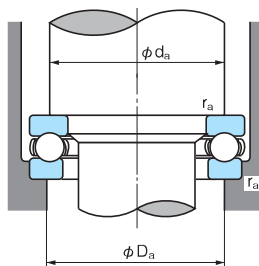

	主要尺寸 (mm)		安裝尺寸 (mm)			參考重量 (kg)	公稱號碼
	$D_1$ (最小)	$d_1$ (最大)	$d_a$ (最小)	$D_a$ (最大)	$r_a$ (最大)		
	10.2	26	19.6	16.4	0.6	0.035	<b>2900</b>
	12.2	28	21.6	18.4	0.6	0.037	<b>2901</b>
	15.2	31	25	21	0.6	0.041	<b>2902</b>
	18.2	35	28	25	0.6	0.045	<b>2903</b>
	20.2	37	30	27	0.6	0.055	<b>2904</b>
	22.2	42	34	30	0.6	0.085	<b>2904 ½</b>
	25.2	45	37	33	0.6	0.093	<b>2905</b>
	30.2	50	42	38	0.6	0.107	<b>2906</b>
	35.2	55	47	43	0.6	0.137	<b>2907</b>
	40.2	60	52	48	0.6	0.150	<b>2908</b>
	45.2	68	59	54	0.6	0.199	<b>2909</b>
	50.2	74	64	60	0.6	0.255	<b>2910</b>
	55.2	78	69	64	0.6	0.270	<b>2911</b>
	60.2	82	73	69	0.6	0.275	<b>2912</b>
	65.2	90	80	75	0.6	0.374	<b>2913</b>
	70.2	95	85	80	0.6	0.400	<b>2914</b>
	75.2	100	90	85	0.6	0.425	<b>2915</b>
	80.2	110	98	92	0.6	0.600	<b>2916</b>
	85.2	115	103	97	0.6	0.640	<b>2917</b>
	90.2	120	108	102	0.6	0.670	<b>2918</b>
	95.2	130	116	109	0.6	0.795	<b>2919</b>
	100.2	135	121	114	0.6	0.930	<b>2920</b>
	105.2	140	126	119	0.6	1.02	<b>2921</b>
	110.2	145	131	124	0.6	1.15	<b>2922</b>
	115.2	150	136	129	0.6	1.25	<b>2923</b>
	120.2	160	144	136	0.6	1.35	<b>2924</b>
	125.3	165	149	141	0.6	1.48	<b>2925</b>
	140.3	185	167	158	0.6	2.33	<b>2928</b>

■ 單式止推滾珠軸承

3900系列

內徑: 25~120mm

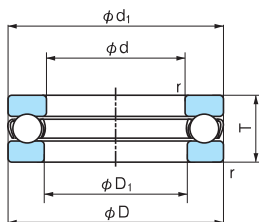

1N=0.102kgf

主要尺寸 (mm)				公稱號碼	基本 額定動 負荷 Ca(N)	基本 額定靜 負荷 Coa(N)	極限轉速 (min <sup>-1</sup> )		
d	D	T	r (最小)				潤滑脂潤滑	油潤滑	
25	52	16	1	3905	27100	50500	3400	5200	
30	60	19	1	3906	38000	72500	2900	4400	
35	68	22	1	3907	50500	99000	2500	3800	
40	76	25	1	3908	61000	119000	2200	3400	
45	85	28	1	3909	79500	163000	2000	3000	
50	92	31	1	3910	97000	202000	1800	2800	
55	100	33	1	3911	110000	240000	1700	2600	
60	106	35	1.5	3912	119000	263000	1600	2400	
65	112	36	1.5	3913	128000	287000	1500	2300	
70	120	38	1.5	3914	143000	335000	1400	2200	
75	128	41	1.5	3915	159000	365000	1300	2000	
80	136	44	1.5	3916	183000	425000	1200	1900	
85	145	47	1.5	3917	207000	490000	1100	1700	
90	155	50	1.5	3918	232000	555000	1100	1600	
95	165	54	1.5	3919	253000	630000	1000	1500	
100	172	57	1.5	3920	250000	630000	980	1400	
105	180	60	2.5	3921	257000	670000	930	1400	
110	190	63	2.5	3922	293000	785000	880	1300	
115	200	66	2.5	3923	315000	870000	840	1200	
120	210	69	2.5	3924	325000	930000	800	1200	

RA

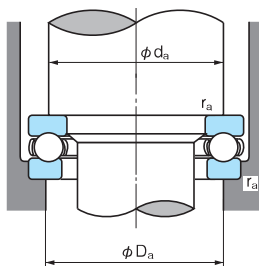

	主要尺寸 (mm)		安裝尺寸 (mm)			參考重量 (kg)	公稱號碼
	$D_1$ (最小)	$d_1$ (最大)	$d_a$ (最小)	$D_a$ (最大)	$r_a$ (最大)		
	25.2	52	42	36	1.0	0.147	<b>3905</b>
	30.2	60	49	43	1.0	0.237	<b>3906</b>
	35.2	68	56.5	48.5	1.0	0.346	<b>3907</b>
	40.2	76	63	55	1.0	0.486	<b>3908</b>
	45.2	85	71	61	1.0	0.684	<b>3909</b>
	50.2	92	77	67	1.0	0.889	<b>3910</b>
	55.2	100	83.5	73.5	1.0	1.114	<b>3911</b>
	60.2	106	89	79	1.5	1.293	<b>3912</b>
	65.2	112	95.5	83.5	1.5	1.443	<b>3913</b>
	70.2	120	102	90	1.5	1.767	<b>3914</b>
	75.2	128	108.5	96.5	1.5	2.132	<b>3915</b>
	80.2	136	115	101	1.5	2.606	<b>3916</b>
	85.2	145	122	108	1.5	3.157	<b>3917</b>
	90.2	155	131	115	1.5	3.907	<b>3918</b>
	95.2	165	139	123	1.5	4.810	<b>3919</b>
	100.2	172	144	128	1.5	5.454	<b>3920</b>
	105.2	180	153	137	2.5	6.354	<b>3921</b>
	110.2	190	159	141	2.5	7.333	<b>3922</b>
	115.2	200	167.5	147.5	2.5	8.526	<b>3923</b>
	120.2	210	178	158	2.5	10.195	<b>3924</b>



■ 單式止推滾珠軸承

英制系列

0系列

內徑:9.525~152.400mm

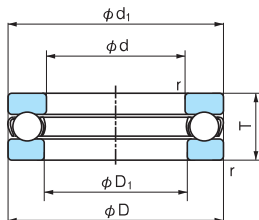

1N=0.102kgf

主要尺寸 (mm)				公稱號碼	基本 額定動 負荷 Ca(N)	基本 額定靜 負荷 Coa(N)	極限轉速 (min <sup>-1</sup> )		
d	D	T	r (最小)				潤滑脂潤滑	油潤滑	
9.525	25.400	13.494	0.8	O - 3	11800	15200	5400	8100	
12.700	32.544	15.875	0.8	O - 4	18600	25100	4300	6500	
15.875	35.719	15.875	0.8	O - 5	19400	28300	4100	6200	
19.050	38.894	15.875	0.8	O - 6	21400	34500	4000	6000	
22.225	42.069	15.875	0.8	O - 7	21900	37500	3800	5800	
25.400	45.244	15.875	1.6	O - 8	22500	41000	3700	5500	
28.575	48.419	15.875	1.6	O - 9	24100	47000	3600	5400	
31.750	53.181	18.256	1.6	O -10	27900	54500	3200	4800	
34.925	56.356	18.256	1.6	O -11	28600	58000	3100	4600	
38.100	59.531	18.256	1.6	O -12	30500	66000	3000	4500	
41.275	62.706	18.256	1.6	O -13	26700	63000	2900	4400	
44.450	68.262	19.050	1.6	O -14	32500	77500	2700	4100	
47.625	71.438	19.050	1.6	O -15	37500	89000	2700	4000	
50.800	75.406	19.050	2.4	O -16	38000	94000	2600	3900	
53.975	81.756	22.225	2.4	O -17	49500	118000	2300	3500	
57.150	84.931	22.225	2.4	O -18	50500	125000	2300	3400	
60.325	91.281	25.400	2.4	O -19	58000	145000	2000	3100	
63.500	94.456	25.400	2.4	O -20	59500	152000	2000	3000	
66.675	97.631	25.400	2.4	O -21	60500	160000	2000	3000	
69.850	102.394	25.400	2.4	O -22	71500	179000	1900	2900	
73.025	105.569	25.400	2.4	O -23	75500	199000	1900	2800	
76.200	111.125	28.575	3.2	O -24	77000	209000	1700	2600	
82.550	122.238	31.750	3.2	O -26	97500	252000	1600	2400	
88.900	128.588	31.750	3.2	O -28	99000	266000	1500	2300	
95.250	134.938	31.750	3.2	O -30	98500	289000	1500	2200	
101.600	147.638	34.925	3.2	O -32	113000	310000	1300	2000	
114.300	166.688	44.450	4.8	O -36	157000	435000	1100	1700	
127.000	185.738	50.800	4.8	O -40	193000	545000	1000	1500	
139.700	204.788	55.562	4.8	O -44	248000	715000	910	1300	
152.400	220.662	60.325	4.8	O -48	269000	805000	830	1200	

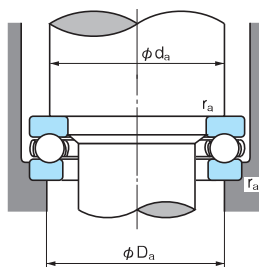

	主要尺寸 (mm)		安裝尺寸 (mm)			參考重量 (kg)	公稱號碼
	$D_1$ (最小)	$d_1$ (最大)	$d_a$ (最小)	$D_a$ (最大)	$r_a$ (最大)		
	9.925	24.606	19.1	15.9	0.8	0.036	O-3
	13.097	31.750	24.6	20.6	0.8	0.077	O-4
	16.272	34.925	27.8	23.8	0.8	0.086	O-5
	19.447	38.100	29	26	0.8	0.095	O-6
	22.622	41.275	34	30	0.8	0.100	O-7
	25.797	44.450	37	33	0.8	0.110	O-8
	28.972	47.625	40	37	0.8	0.128	O-9
	32.147	52.388	45	40	0.8	0.164	O-10
	35.322	55.562	48	43	0.8	0.186	O-11
	38.497	58.738	51	47	1	0.200	O-12
	41.672	61.912	54	50	1	0.210	O-13
	44.847	67.469	59	54	1	0.260	O-14
	48.021	70.644	62	57	1	0.285	O-15
	51.594	74.613	66	61	1	0.300	O-16
	54.769	80.962	71	65	1.6	0.405	O-17
	57.944	84.138	74	68	1.6	0.450	O-18
	61.119	90.488	79	73	1.6	0.590	O-19
	64.294	93.662	82	76	1.6	0.610	O-20
	67.469	96.838	85	79	1.6	0.660	O-21
	70.644	101.600	89	83	1.6	0.700	O-22
	73.819	104.775	93	86	1.6	0.730	O-23
	77.788	109.538	97	90	2	0.900	O-24
	84.138	120.650	106	98	2	1.30	O-26
	90.488	127.000	113	105	2	1.32	O-28
	96.838	133.350	119	111	2	1.36	O-30
	103.188	146.050	129	120	2	1.88	O-32
	115.888	165.100	146	135	3	3.18	O-36
	128.588	184.150	162	150	3	4.54	O-40
	141.288	203.200	179	166	3	5.90	O-44
	153.988	219.075	193	180	3	7.25	O-48

■ 小型・微型止推滾珠軸承

TAM形

內徑：3~8mm

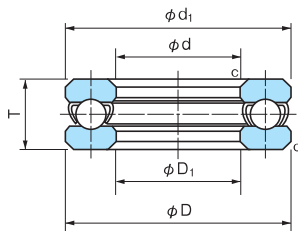

1N=0.102kgf

主要尺寸 (mm)						公稱號碼	基本額定動負荷 Ca(N)	基本額定靜負荷 Coa(N)	參考重量 (g)
d	D	T	c	D <sub>1</sub>	d <sub>1</sub>				
3	8	3.5	0.2	3.2	8	<b>3TAM8</b>	1790	1720	0.6
4	9	4	0.2	4.1	9	<b>4TAM9</b>	1860	1970	0.8
5	10	4	0.3	5.1	10	<b>5TAM10</b>	1930	2220	0.9
6	12	4.5	0.3	6.2	12	<b>6TAM12</b>	1820	2220	1.7
7	14	4.5	0.3	7.2	14	<b>7TAM14</b>	2480	3140	2.3
8	16	5	0.3	8.2	16	<b>8TAM16</b>	3920	4990	3.4

## ■ 小型・微型止推滾珠軸承

### TG形（帶外殼）

內徑：5~8mm

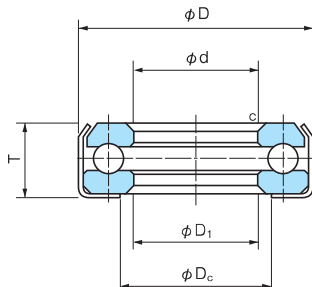

1N=0.102kgf

主要尺寸 (mm)						公稱號碼	基本 額定動 負荷 Ca(N)	基本 額定靜 負荷 Coa(N)	參考重量 (g)
d	D	T	c	D <sub>1</sub>	D <sub>c</sub>				
5	10	4.2	0.3	5.1	5.8	<b>5TG-10</b>	2200	2710	1.3
6	12	4.7	0.5	6.2	7.2	<b>6TG-12</b>	2450	3450	2.2
7	14	4.7	0.5	7.2	8.2	<b>7TG-14</b>	3320	4890	3.0
8	16	5.2	0.5	8.2	9.2	<b>8TG-16</b>	4750	6650	4.0

# ■ 複式止推滾珠軸承

內徑: 15~75mm

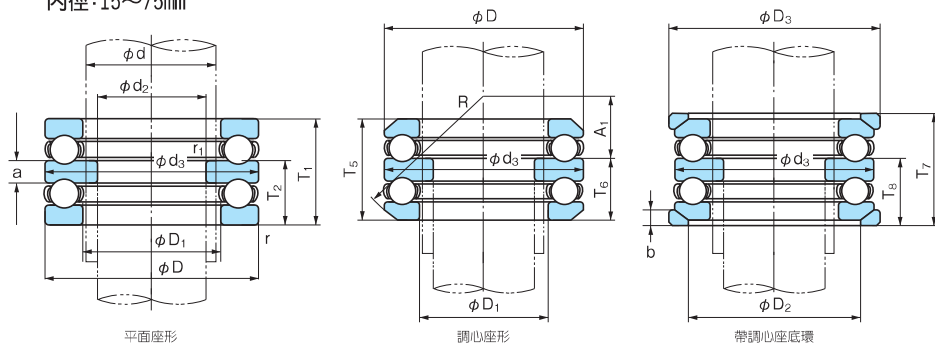

1N=0.102kgf

主要尺寸 (mm)								公稱號碼			基本 額定動 負荷 Ca(N)	基本 額定靜 負荷 Coa(N)	極限轉速 (min <sup>-1</sup> )	
d	d <sub>2</sub>	D	T <sub>1</sub>	T <sub>5</sub>	T <sub>7</sub>	r (最小)	r <sub>1</sub> (最小)	平面 座形	調心 座形	帶調心 座底環			潤滑脂 潤滑	油潤滑
15	10	32	22	24.6	28	0.6	0.3	52202	54202	54202U	16600	24800	5100	7600
20	15	40	26	27.4	32	0.6	0.3	52204	54204	54204U	22200	37500	4200	6300
25	20	47	28	31.4	36	0.6	0.3	52205	54205	54205U	27800	50500	3700	5600
	20	52	34	37.6	42	1	0.3	52305	54305	54305U	35500	61500	3200	4900
30	15	60	45	49.8	55	1	0.6	52405	54405	54405U	55500	89500	2600	3900
	25	52	29	32.6	37	0.6	0.3	52206	54206	54206U	29300	58000	3400	5200
35	25	60	38	41.2	46	1	0.3	52306	54306	54306U	42500	78500	2800	4200
	20	70	52	56.2	62	1	0.6	52406	54406	54406U	72500	126000	2200	3300
40	30	62	34	37.8	42	1	0.3	52207	54207	54207U	39000	78000	2900	4400
	30	68	44	47.2	52	1	0.3	52307	54307	54307U	55500	105000	2400	3700
45	25	80	59	63	69	1.1	0.6	52407	54407	54407U	87000	155000	1900	2900
	30	68	36	38.6	44	1	0.6	52208	54208	54208U	47000	98500	2700	4100
50	30	78	49	54	59	1	0.6	52308	54308	54308U	69000	135000	2200	3300
	30	90	65	69.4	77	1.1	0.6	52408	54408	54408U	112000	205000	1700	2600
55	35	73	37	39.6	45	1	0.6	52209	54209	54209U	47500	105000	2600	3900
	35	85	52	56.2	62	1	0.6	52309	54309	54309U	80000	163000	2000	3000
60	35	100	72	78.8	86	1.1	0.6	52409	54409	54409U	129000	243000	1600	2400
	40	78	39	42	47	1	0.6	52210	54210	54210U	48500	112000	2400	3600
65	40	95	58	64.6	70	1.1	0.6	52310	54310	54310U	96500	202000	1800	2700
	40	110	78	83.2	92	1.5	0.6	52410	54410	54410U	148000	283000	1400	2100
70	45	90	45	49.6	55	1	0.6	52211	54211	54211U	69500	159000	2100	3100
	45	105	64	72.6	78	1.1	0.6	52311	54311	54311U	120000	246000	1600	2400
75	45	120	87	92	101	1.5	0.6	52411	54411	54411U	178000	360000	1300	1900
	50	95	46	50	56	1	0.6	52212	54212	54212U	73500	179000	2000	3000
80	50	110	64	70.6	78	1.1	0.6	52312	54312	54312U	123000	267000	1600	2400
	50	130	93	99	107	1.5	0.6	52412	54412	54412U	213000	435000	1200	1800
85	55	100	47	50.4	57	1	0.6	52213	54213	54213U	75000	189000	1900	2800
	55	115	65	71.8	79	1.1	0.6	52313	54313	54313U	127000	287000	1500	2300
90	50	140	101	109.4	119	2	1	52413	54413	54413U	231000	495000	1100	1600
	55	105	47	50.6	57	1	1	52214	54214	54214U	76000	199000	1800	2800
95	55	125	72	80.4	88	1.1	1	52314	54314	54314U	148000	340000	1400	2100
	55	150	107	114.2	125	2	1	52414	54414	54414U	250000	555000	1000	1500
100	60	110	47	49.6	57	1	1	52215	54215	54215U	77500	209000	1800	2700
	60	135	79	87.2	95	1.5	1	52315	54315	54315U	170000	395000	1200	1900
105	60	160	115	123	135	2	1	52415	54415	54415U	252000	560000	950	1400

RA

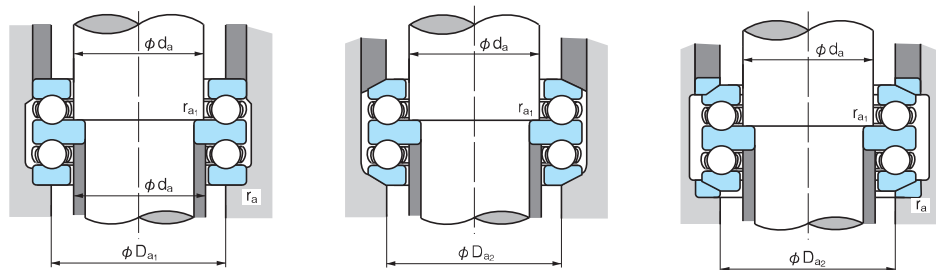

主要尺寸 (mm)											安裝尺寸 (mm)						參考重量 (kg)			公稱 號碼
$d_3$ (最大)	$D_1$ (最小)	$D_2$	$D_3$	$T_2$	$T_6$	$T_8$	a	b	$A_1$	R	$d_a$ (最小)	$D_{a1}$ (最大)	$D_{a2}$ (最大)	$r_a$ (最大)	$r_{a1}$ (最大)	平面 座形	調心 座形	帶調心 座底環		
32	17	24	35	13.5	14.8	16.5	5	4	10.5	28	15	22	24	0.6	0.3	0.085	0.090	0.116	52202	
40	22	30	42	16	16.7	19	6	5	16	36	20	28	30	0.6	0.3	0.150	0.147	0.189	52204	
47	27	36	50	17.5	19.2	21.5	7	5.5	16.5	40	25	34	36	0.6	0.3	0.230	0.241	0.305	52205	
52	27	38	55	21	22.8	25	8	6	18	45	25	36	38	1	0.3	0.330	0.340	0.431	52305	
60	27	42	62	28	30.4	33	11	8	15	50	25	39	42	1	0.6	0.630	0.650	0.796	52405	
52	32	42	55	18	19.8	22	7	5.5	20	45	30	39	42	0.6	0.3	0.272	0.291	0.356	52206	
60	32	45	62	23.5	25.1	27.5	9	7	19.5	50	30	42	45	1	0.3	0.490	0.495	0.607	52306	
70	32	50	75	32	34.1	37	12	9	16	56	30	46	50	1	0.6	1.00	1.00	1.26	52406	
62	37	48	65	21	22.9	25	8	7	21	50	35	46	48	1	0.3	0.420	0.431	0.550	52207	
68	37	52	72	27	28.6	31	10	7.5	21	56	35	48	52	1	0.3	0.710	0.711	0.881	52307	
80	37	58	85	36.5	38.5	41.5	14	10	18.5	64	35	53	58	1	0.6	1.44	1.43	1.78	52407	
68	42	55	72	22.5	23.8	26.5	9	7	25	56	40	51	55	1	0.6	0.540	0.542	0.686	52208	
78	42	60	82	30.5	33	35.5	12	8.5	23.5	64	40	55	60	1	0.6	1.06	1.10	1.33	52308	
90	42	65	95	40	42.2	46	15	12	22	72	40	60	65	1	0.6	2.03	2.00	2.52	52408	
73	47	60	78	23	24.3	27	9	7.5	23	56	45	56	60	1	0.6	0.620	0.617	0.796	52209	
85	47	65	90	32	34.1	37	12	10	21	64	45	61	65	1	0.6	1.29	1.28	1.63	52309	
100	47	72	105	44.5	47.9	51.5	17	12.5	23.5	80	45	67	72	1	0.6	2.71	2.76	3.40	52409	
78	52	62	82	24	25.5	28	9	7.5	30.5	64	50	61	62	1	0.6	0.71	0.697	0.899	52210	
95	52	72	100	36	39.3	42	14	11	23	72	50	68	72	1	0.6	1.86	1.92	2.37	52310	
110	52	80	115	48	50.6	55	18	14	30	90	50	74	80	1.5	0.6	3.56	3.52	4.36	52410	
90	57	72	95	27.5	29.8	32.5	10	9	32.5	72	55	69	72	1	0.6	1.12	1.14	1.54	52211	
105	57	80	110	39.5	43.8	46.5	15	11.5	25.5	80	55	75	80	1	0.6	2.51	2.65	3.22	52311	
120	57	88	125	53.5	56	60.5	20	15.5	22.5	90	55	81	88	1.5	0.6	4.70	4.55	5.64	52411	
95	62	78	100	28	30	33	10	9	30.5	72	60	74	78	1	0.6	1.25	1.26	1.59	52212	
110	62	85	115	39.5	42.8	46.5	15	11.5	36.5	90	60	80	85	1	0.6	2.68	2.76	3.39	52312	
130	62	95	135	57	60	64	21	16	28	100	60	88	95	1.5	0.6	6.33	6.20	7.45	52412	
100	67	82	105	28.5	30.2	33.5	10	9	38.5	80	65	79	82	1	0.6	1.36	1.35	1.72	52213	
115	67	90	120	40	43.4	47	15	12.5	34.5	90	65	85	90	1	0.6	2.90	2.98	3.67	52313	
140	68	100	145	62	66.2	71	23	17.5	34	112	65	95	100	2	1	8.03	8.01	9.67	52413	
105	72	88	110	28.5	30.3	33.5	10	9	36.5	80	70	84	88	1	1	1.48	1.48	1.86	52214	
125	72	98	130	44	48.2	52	16	13	39	100	70	92	98	1	1	3.90	4.08	4.92	52314	
150	73	110	155	65.5	69.1	74.5	24	19.5	28.5	112	70	102	110	2	1	9.71	9.50	11.5	52414	
110	77	92	115	28.5	29.8	33.5	10	9.5	47.5	90	75	89	92	1	1	1.57	1.57	1.96	52215	
135	77	105	140	48.5	52.6	56.5	18	15	32.5	100	75	99	105	1.5	1	4.83	4.93	6.04	52315	
160	78	115	165	70.5	74.5	80.5	26	21	36.5	125	75	109	115	2	1	11.8	11.6	14.1	52415	

100

# ■ 複式止推滾珠軸承

內徑: 80~170mm

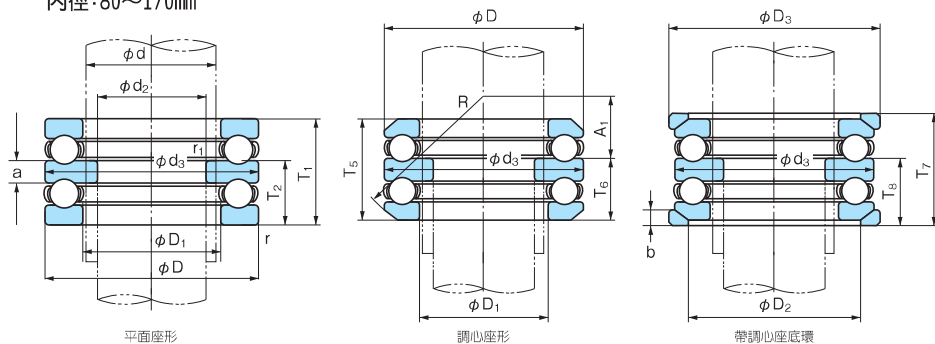

1N=0.102kgf

主要尺寸 (mm)								公稱號碼			基本 額定動 負荷 Ca(N)	基本 額定靜 負荷 Coa(N)	極限轉速 (min <sup>-1</sup> )	
d	d <sub>2</sub>	D	T <sub>1</sub>	T <sub>5</sub>	T <sub>7</sub>	r (最小)	r <sub>1</sub> (最小)	平面 座形	調心 座形	帶調心 座底環			潤滑脂 潤滑	油潤滑
80	65	115	48	51	58	1	1	52216	54216	54216U	78500	219000	1700	2600
	65	140	79	86.2	95	1.5	1	52316	54316	54316U	176000	425000	1200	1800
	65	170	120	128.4	140	2.1	1	52416	54416	54416U	270000	620000	900	1300
85	70	125	55	59.2	67	1	1	52217	54217	54217U	95500	264000	1600	2400
	70	150	87	95.2	105	1.5	1	52317	54317	54317U	206000	490000	1100	1700
	65	180	128	138	150	2.1	1.1	52417	54417	54417U	288000	685000	850	1200
90	75	135	62	69	76	1.1	1	52218	54218	54218U	116000	325000	1400	2100
	75	165	88	97.2	106	1.5	1	52318	54318	54318U	213000	525000	1100	1600
	70	190	135	143.4	157	2.1	1.1	52418	54418	54418U	305000	750000	790	1100
100	85	150	67	72.8	81	1.1	1	52220	54220	54220U	146000	410000	1300	1900
	85	170	97	105.4	115	1.5	1	52320	54320	54320U	236000	595000	1000	1500
	80	210	150	160	176	3	1.1	52420	54420	54420U	345000	895000	710	1000
110	95	160	67	71.4	81	1.1	1	52222	54222	54222U	153000	450000	1200	1900
	95	190	110	118.4	128	2	1	52322	54322	54322U	268000	705000	880	1300
	90	230	166	—	—	3	1.1	52422	—	—	435000	1240000	640	960
120	100	170	68	71.6	82	1.1	1.1	52224	54224	54224U	152000	470000	1200	1800
	100	210	123	131.2	143	2.1	1.1	52324	54324	54324U	267000	870000	790	1100
	95	250	177	—	—	4	1.5	52424	—	—	455000	1340000	580	880
130	110	190	80	85.8	96	1.5	1.1	52226	54226	54226U	203000	620000	1000	1500
	110	225	130	—	—	2.1	1.1	52326	—	—	330000	960000	730	1100
	100	270	192	—	—	4	2	52426	—	—	555000	1750000	540	810
140	120	200	81	86.2	99	1.5	1.1	52228	54228	54228U	205000	650000	1000	1500
	120	240	140	—	—	2.1	1.1	52328	—	—	350000	1050000	680	1000
	110	280	196	—	—	4	2	52428	—	—	545000	1750000	520	780
150	130	215	89	95.6	109	1.5	1.1	52230	54230	54230U	213000	650000	940	1400
	130	250	140	—	—	2.1	1.1	52330	—	—	360000	1130000	670	1000
	120	300	209	—	—	4	2	52430	—	—	615000	2010000	480	720
160	140	225	90	97.4	110	1.5	1.1	52232	54232	54232U	223000	720000	900	1300
	140	270	153	—	—	3	1.1	52332	—	—	410000	1340000	610	920
	130	320	226	—	—	5	2	52432	—	—	680000	2410000	440	670
170	150	240	97	104.4	117	1.5	1.1	52234	54234	54234U	261000	835000	840	1200
	150	280	153	—	—	3	1.1	52334	—	—	420000	1430000	600	900
	135	340	236	—	—	5	2.1	52434	—	—	755000	2730000	420	630

RA

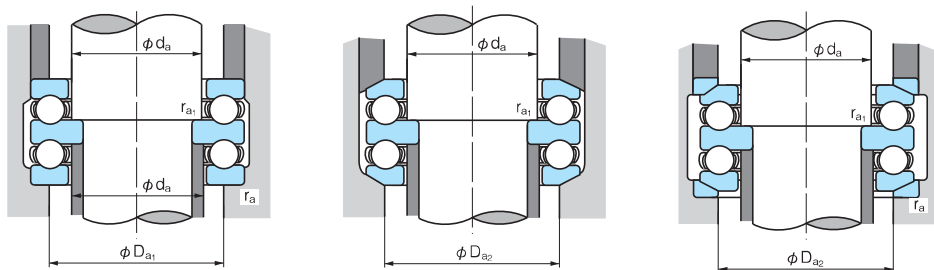

	主要尺寸 (mm)											安裝尺寸 (mm)					參考重量 (kg)			公稱 號碼
	$d_3$ (最大)	$D_1$ (最小)	$D_2$	$D_3$	$T_2$	$T_6$	$T_8$	a	b	$A_1$	R	$d_a$ (最小)	$D_{a1}$ (最大)	$D_{a2}$ (最大)	$r_a$ (最大)	$r_{a1}$ (最大)	平面 座形	調心 座形	帶調心 座環	
	115	82	98	120	29	30.5	34	10	10	45	90	80	94	98	1	1	1.69	1.67	2.11	52216
	140	82	110	145	48.5	52.1	56.5	18	15	45.5	112	80	104	110	1.5	1	5.06	5.14	6.29	52316
	170	83	125	175	73.5	77.7	83.5	27	22	30.5	125	80	116	125	2	1	14.0	13.7	16.5	52416
	125	88	105	130	33.5	35.6	39.5	12	11	49.5	100	85	101	105	1	1	2.34	2.34	2.93	52217
	150	88	115	155	53	57.1	62	19	17.5	39	112	85	111	115	1.5	1	6.43	6.41	8.05	52317
	179.5	88	130	185	78.5	83.5	89.5	29	23	40.5	140	85	123	130	2	1	17.5	17.3	20.7	52417
	135	93	110	140	38	41.5	45	14	13.5	42	100	90	108	110	1	1	3.22	3.25	4.12	52218
	155	93	120	160	53.5	58.1	62.5	19	18	36.5	112	90	116	120	1.5	1	6.60	6.62	8.33	52318
	189.5	93	140	195	82.5	86.7	93.5	30	25.5	34.5	140	90	130	140	2	1	19.6	19.1	23.0	52418
	150	103	125	155	41	43.9	48	15	14	49	112	100	120	125	1	1	4.29	4.29	5.32	52220
	170	103	135	175	59	63.2	68	21	18	42	125	100	128	135	1.5	1	8.90	8.92	10.8	52320
	209.5	103	155	220	91.5	96.5	104.5	33	27	43.5	160	100	144	155	2.5	1	26.6	26.2	32.0	52420
	160	113	135	165	41	43.2	48	15	14	62	125	110	130	135	1	1	4.68	4.60	5.74	52222
	189.5	113	150	195	67	71.2	76	24	20.5	47	140	110	142	150	2	1	13.8	13.7	16.3	52322
	229	113	—	—	101.5	—	—	37	—	—	—	110	158	—	2.5	1	34.9	—	—	52422
	170	123	145	175	41.5	43.3	48.5	15	15	58.5	125	120	140	145	1	1	5.24	5.04	6.36	52224
	209.5	123	165	220	75	79.1	85	27	22	58	160	120	156	165	2	1	17.2	16.9	21.0	52324
	249	123	—	—	108.5	—	—	40	—	—	—	120	172	—	3	1.5	44.2	—	—	52424
	189.5	133	160	195	49	51.9	57	18	17	63	140	130	154	160	1.5	1	7.72	7.58	9.43	52226
	224	134	—	—	80	—	—	30	—	—	—	130	168	—	2	1	22.1	—	—	52326
	269	134	—	—	117	—	—	42	—	—	—	130	186	—	3	2	56.5	—	—	52426
	199.5	143	170	210	49.5	52.1	58.5	18	17	83.5	160	140	164	170	1.5	1	8.93	8.79	11.3	52228
	239	144	—	—	85.5	—	—	31	—	—	—	140	180	—	2	1	27.8	—	—	52328
	279	144	—	—	120	—	—	44	—	—	—	140	196	—	3	2	60.6	—	—	52428
	214.5	153	180	225	54.5	57.8	64.5	20	20.5	74.5	180	150	176	180	1.5	1	10.6	10.3	13.8	52230
	249	154	—	—	85.5	—	—	31	—	—	—	150	190	—	2	1	29.2	—	—	52330
	299	153	—	—	127.5	—	—	46	—	—	—	150	210	—	3	2	73.9	—	—	52430
	224.5	163	190	235	55	58.7	65	20	21	70	160	160	186	190	1.5	1	12.2	11.9	15.6	52232
	269	164	—	—	93	—	—	33	—	—	—	160	204	—	2.5	1	37.7	—	—	52332
	319	164	—	—	138	—	—	50	—	—	—	160	224	—	4	2	90.3	—	—	52432
	239.5	173	200	250	59	62.7	69	21	21.5	87	180	170	198	200	1.5	1	15.2	14.7	19.1	52234
	279	174	—	—	93	—	—	33	—	—	—	170	214	—	2.5	1	39.8	—	—	52334
	339	174	—	—	143	—	—	50	—	—	—	170	238	—	4	2	108	—	—	52434

100



# ■ 複式止推滾珠軸承

內徑: 180~220mm

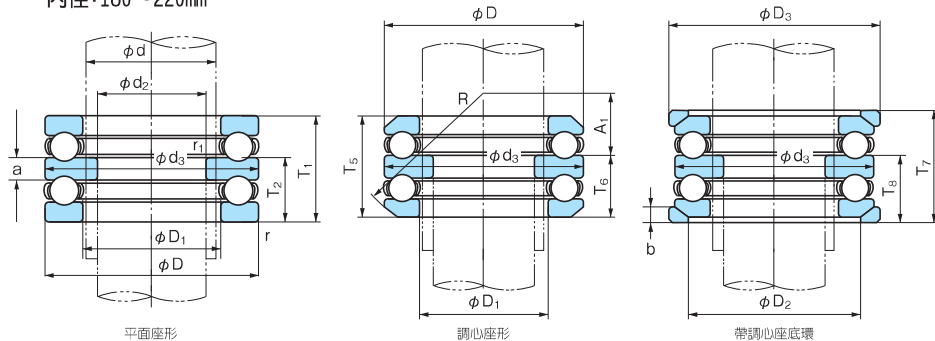

1N=0.102kgf

主要尺寸 (mm)								公稱號碼			基本額定動負荷 Ca(N)	基本額定靜負荷 Coa(N)	極限轉速 (min <sup>-1</sup> )	
d	d <sub>2</sub>	D	T <sub>1</sub>	T <sub>5</sub>	T <sub>7</sub>	r (最小)	r <sub>1</sub> (最小)	平面座形	調心座形	帶調心座底環			潤滑脂潤滑	油潤滑
180	150	250	98	102.4	118	1.5	2	52236	54236	54236U	266000	875000	810	1200
	150	300	165	—	—	3	2	52336	—	—	485000	1700000	550	820
	140	360	245	—	—	5	3	52436	—	—	785000	2980000	400	600
190	160	270	109	116.4	131	2	2	52238	54238	54238U	310000	1060000	740	1100
	160	320	183	—	—	4	2	52338	—	—	570000	2100000	500	750
200	170	280	109	115.6	133	2	2	52240	54240	54240U	315000	1110000	720	1000
	170	340	192	—	—	4	2	52340	—	—	625000	2380000	470	710
220	190	300	110	115.2	134	2	2	52244	54244	54244U	325000	1210000	690	1000

RA

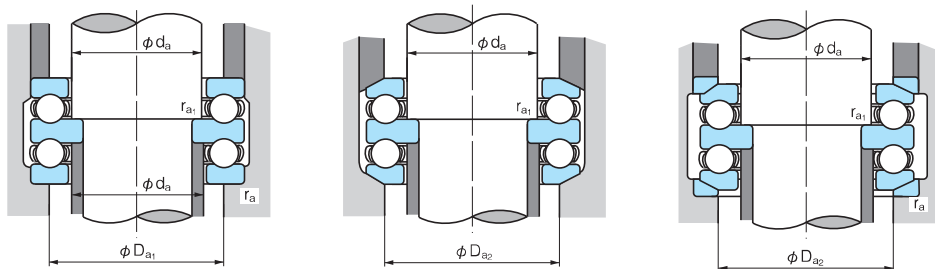

主要尺寸 (mm)												安裝尺寸 (mm)					參考重量 (kg)			公稱 號碼
$d_3$ (最大)	$D_1$ (最小)	$D_2$	$D_3$	$T_2$	$T_6$	$T_8$	a	b	$A_1$	R	$d_a$ (最小)	$D_{a1}$ (最大)	$D_{a2}$ (最大)	$r_a$ (最大)	$r_{a1}$ (最大)	平面 座形	調心 座形	帶調心 座底環		
249	183	210	260	59.5	61.7	69.5	21	21.5	108.5	200	180	208	210	1.5	2	16.0	15.2	19.9	52236	
299	184	—	—	101	—	—	37	—	—	—	180	228	—	2.5	2	50.9	—	—	52336	
359	184	—	—	148.5	—	—	52	—	—	—	180	252	—	4	2.5	126	—	—	52436	
269	194	230	280	66.5	70.2	77.5	24	23	93.5	200	190	222	230	2	2	21.6	21.2	26.5	52238	
319	195	—	—	111.5	—	—	40	—	—	—	190	242	—	3	2	64.9	—	—	52338	
279	204	240	290	66.5	69.8	78.5	24	23	120.5	225	200	232	240	2	2	22.7	22.3	28.0	52240	
339	205	—	—	117	—	—	42	—	—	—	200	256	—	3	2	77.8	—	—	52340	
299	224	260	310	67	69.6	79	24	25	114	225	220	252	260	2	2	23.9	22.9	29.6	52244	

