



JQA-1973
JQA-EM4783

ASAHI Wide product range of high quality.

Table Units

Bearing Units ▼

MAIN PRODUCTS
 Bearing Units
 Linear Motion Units
 Rod Ends

▲ Joinbats

ASAHI

MOTION GUIDE SYSTEMS



ASAHI SEIKO CO., LTD.

<http://www.asahiseiko.co.jp>

FOREIGN TRADE DEPARTMENT : 570-1, Otori-Higashi-machi 6-cho, Nishi-ku, Sakai City, Osaka 593-8324, Japan

Tel : +81-72-272-6900

Fax : +81-72-272-6903

e-mail address : info@asahiseiko.co.jp

U.S.A. OFFICE : 570 North Wheeling Road, Mount Prospect, Illinois 60056 U.S.A.

Tel : +1-847-759-0620

Fax : +1-847-759-0630

CHINA OFFICE : Room#20C, Secondary Building, Lvjingguangchang, Chegongmiao, Shennan Road,

Futian District, Shenzhen City, Guangdong Province, China. 518048

Tel : +86-755-23902930 23605690 23605700

Fax : +86-755-23607911

HEAD OFFICE & FACTORY : 570-1, Otori-Higashi-machi 6-cho, Nishi-ku, Sakai City, Osaka 593-8324, Japan

Tel : +81-72-271-1221

Fax : +81-72-273-0058

ASAHI SEIKO CO., LTD.

ASAHI MOTION GUIDE SYSTEMS

for flex design of conveying system



Motion Guide Systems provide smooth running of V-shaped rolling bearings fitted on both sides of flat rail.

Various combinations of components are available for machine designers' choice to fit their specific applications, including curving movement.

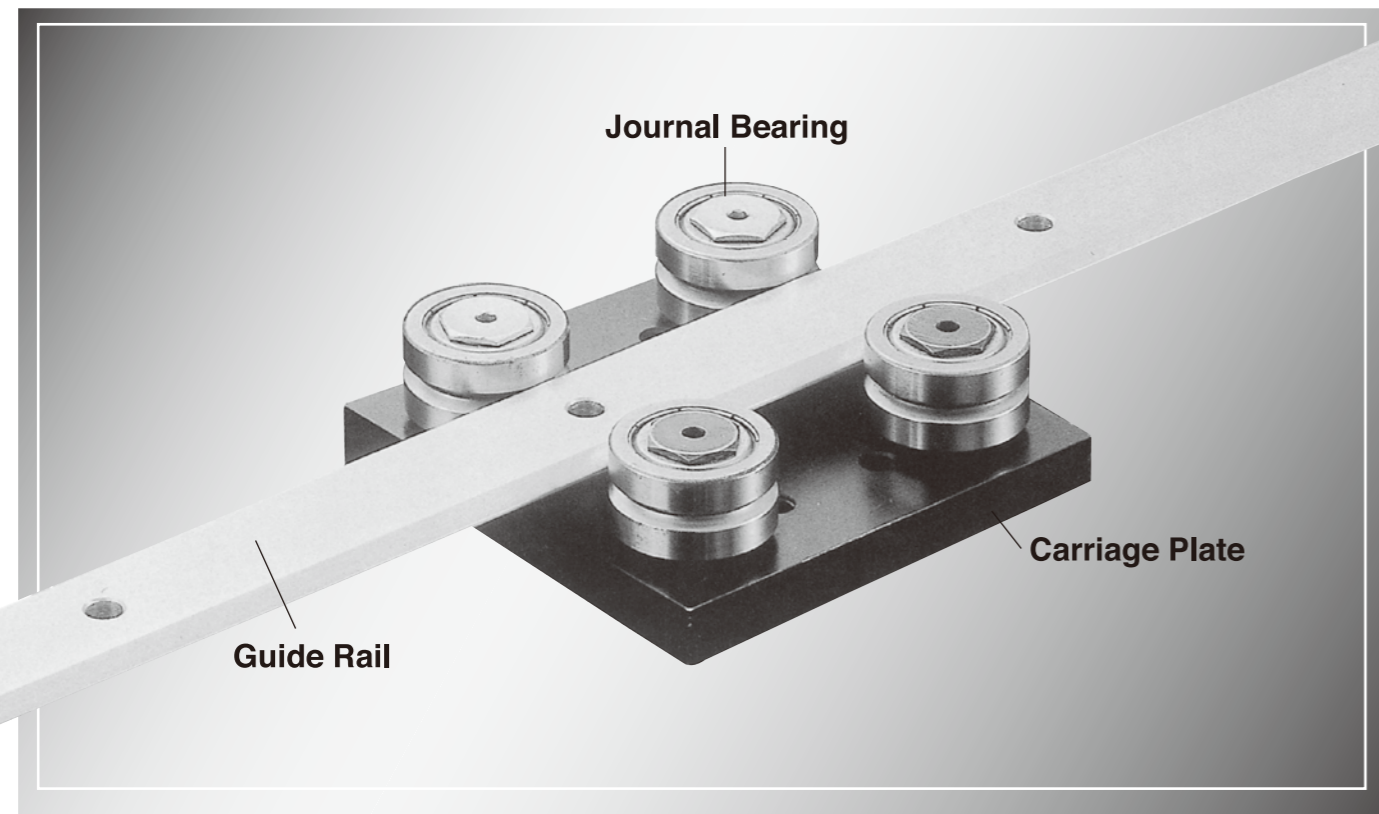

FEATURES

- Sliding-friction-free construction when running not only on straight rail but also on curved rail
- Variety of assembly combinations, including curved rail
- Hard-Chromium-plated Rail surface and hardened V-shaped area
- Clearance adjustable
- Easy for mounting

CONSTRUCTION

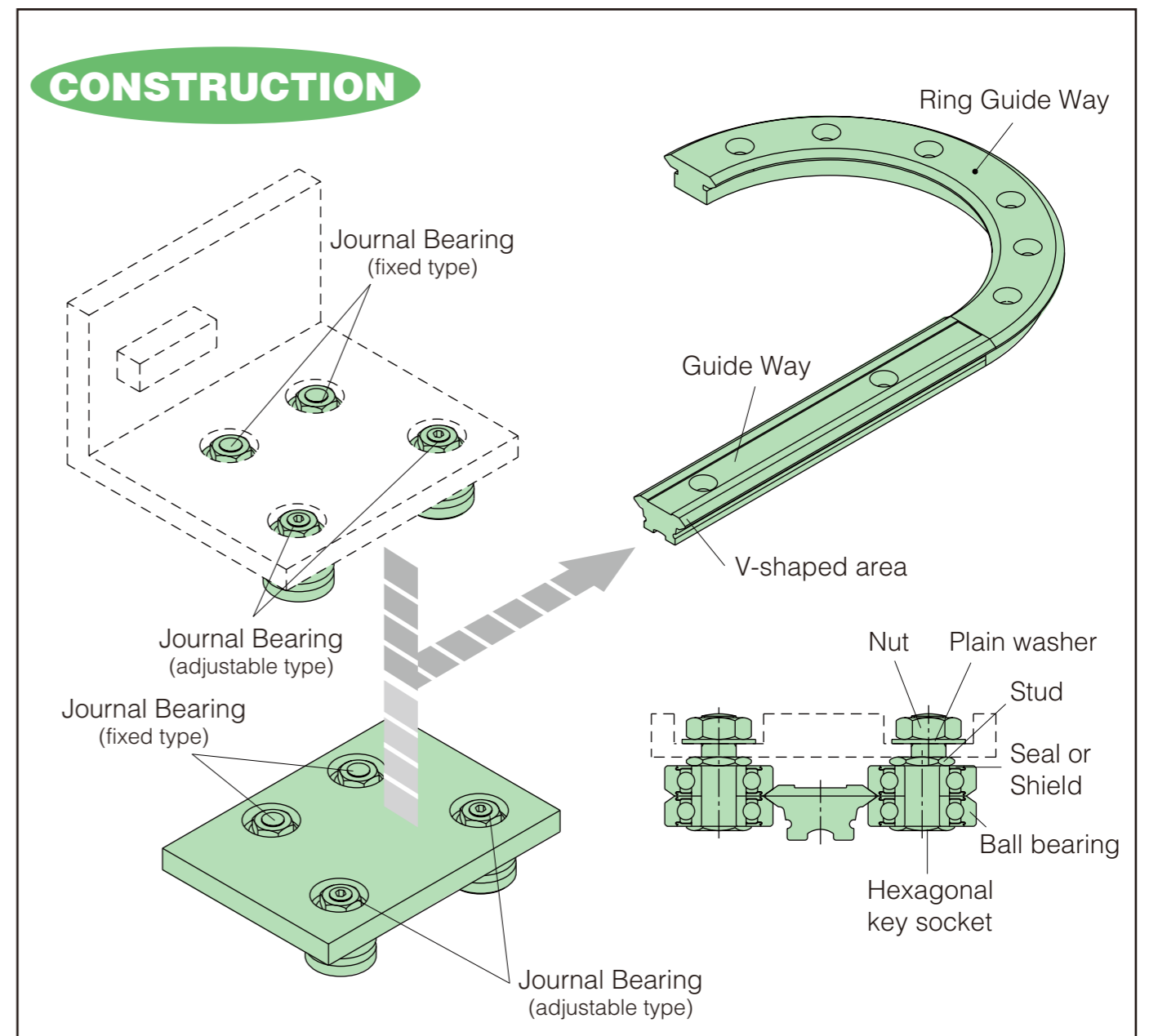



Wide-range variation, either by unit or by components

Basic assembly

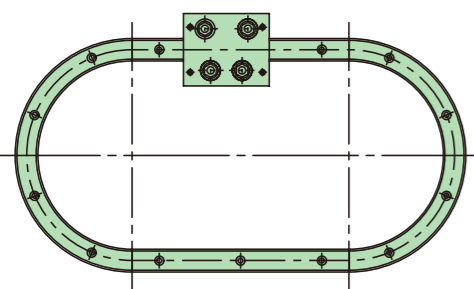
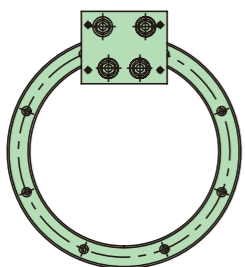
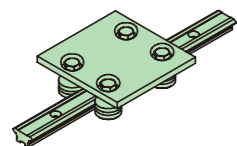

Special products on customer's request

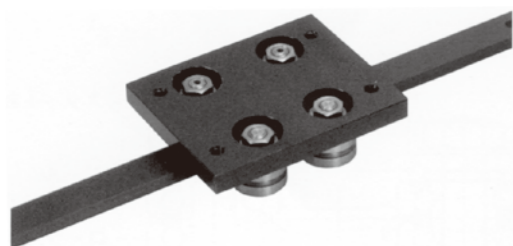

※Example :
Stainless type
Low temperature black chrome plating

Assembled parts

R assembly of Ring Guide Way

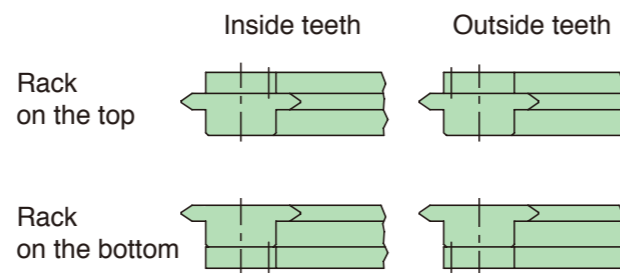

Rail Assembly

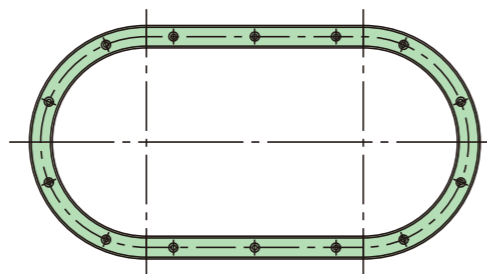

Track type

Carriage Assembly

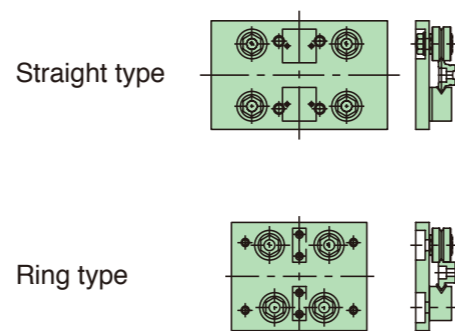

Components

Rail

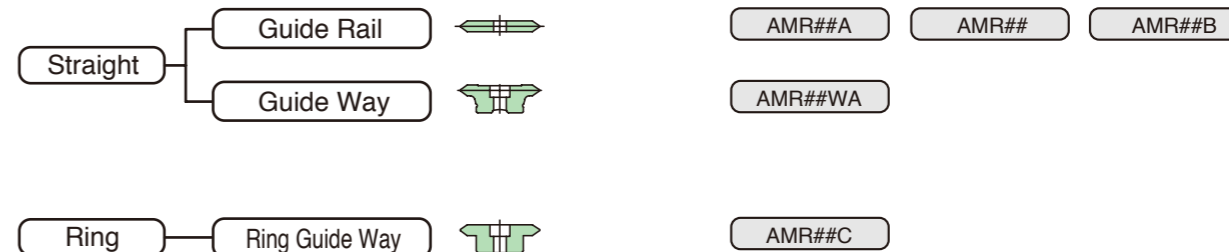

Carriage Plate

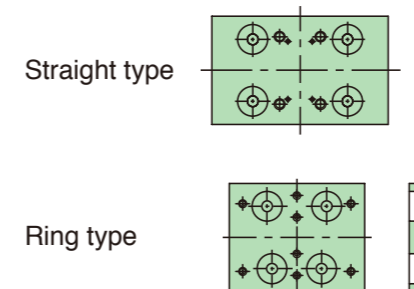

Other parts

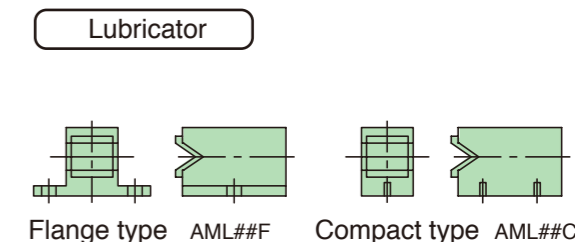

Journal Bearings

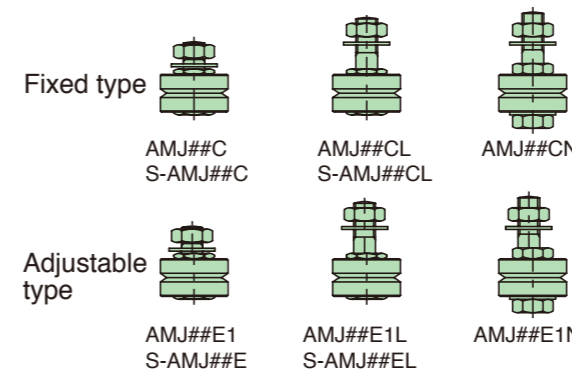

Steel Shield type : As above.
Rubber Seal type : Please add the suffix "-UU".
Stainless Series : Please add the prefix "S-".

Semi-standard / Special

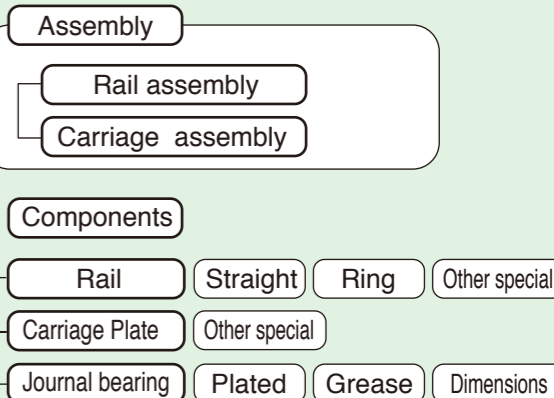

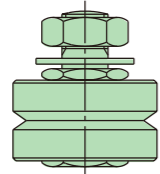
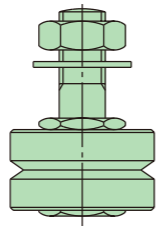
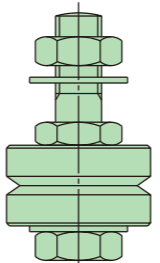
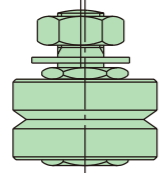
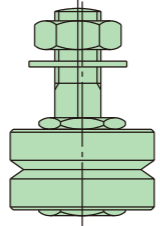
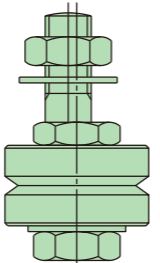

Journal Bearings

	Short type	Long type	Lock nut type																
Fixed type	 <table border="1"> <thead> <tr> <th>Material</th> <th>Part number</th> </tr> </thead> <tbody> <tr> <td>Standard type</td> <td>AMJ##C AMJ##C-UU</td> </tr> <tr> <td>Stainless type</td> <td>S-AMJ##C S-AMJ##C-UU</td> </tr> </tbody> </table>	Material	Part number	Standard type	AMJ##C AMJ##C-UU	Stainless type	S-AMJ##C S-AMJ##C-UU	 <table border="1"> <thead> <tr> <th>Material</th> <th>Part number</th> </tr> </thead> <tbody> <tr> <td>Standard type</td> <td>AMJ##C AMJ##C-UU</td> </tr> <tr> <td>Stainless type</td> <td>S-AMJ##CL S-AMJ##CL-UU</td> </tr> </tbody> </table>	Material	Part number	Standard type	AMJ##C AMJ##C-UU	Stainless type	S-AMJ##CL S-AMJ##CL-UU	 <table border="1"> <thead> <tr> <th>Material</th> <th>Part number</th> </tr> </thead> <tbody> <tr> <td>Standard type</td> <td>AMJ##CN AMJ##CN-UU</td> </tr> </tbody> </table>	Material	Part number	Standard type	AMJ##CN AMJ##CN-UU
Material	Part number																		
Standard type	AMJ##C AMJ##C-UU																		
Stainless type	S-AMJ##C S-AMJ##C-UU																		
Material	Part number																		
Standard type	AMJ##C AMJ##C-UU																		
Stainless type	S-AMJ##CL S-AMJ##CL-UU																		
Material	Part number																		
Standard type	AMJ##CN AMJ##CN-UU																		
Adjustable type	 <table border="1"> <thead> <tr> <th>Material</th> <th>Part number</th> </tr> </thead> <tbody> <tr> <td>Standard type</td> <td>AMJ##E1 AMJ##E1-UU</td> </tr> <tr> <td>Standard type</td> <td>S-AMJ##E S-AMJ##E-UU</td> </tr> </tbody> </table>	Material	Part number	Standard type	AMJ##E1 AMJ##E1-UU	Standard type	S-AMJ##E S-AMJ##E-UU	 <table border="1"> <thead> <tr> <th>Material</th> <th>Part number</th> </tr> </thead> <tbody> <tr> <td>Standard type</td> <td>AMJ##E1L AMJ##E1L-UU</td> </tr> <tr> <td>Standard type</td> <td>S-AMJ##EL S-AMJ##EL-UU</td> </tr> </tbody> </table>	Material	Part number	Standard type	AMJ##E1L AMJ##E1L-UU	Standard type	S-AMJ##EL S-AMJ##EL-UU	 <table border="1"> <thead> <tr> <th>Material</th> <th>Part number</th> </tr> </thead> <tbody> <tr> <td>Standard type</td> <td>AMJ##E1N AMJ##E1N-UU</td> </tr> </tbody> </table>	Material	Part number	Standard type	AMJ##E1N AMJ##E1N-UU
Material	Part number																		
Standard type	AMJ##E1 AMJ##E1-UU																		
Standard type	S-AMJ##E S-AMJ##E-UU																		
Material	Part number																		
Standard type	AMJ##E1L AMJ##E1L-UU																		
Standard type	S-AMJ##EL S-AMJ##EL-UU																		
Material	Part number																		
Standard type	AMJ##E1N AMJ##E1N-UU																		

Note: 1. ## means standard length of applicable rail. (12mm, 25mm, 44mm, 76mm)
 ※ For the rail with the width of 12mm, please consult us in advance.
 2. Rubber seal type is identified by the suffix "-UU".
 3. Refer to P.19 and 20 for mounting.

Any dust or scratch on the race surface may cause noise. Handle with care.

Rail

Types & features

12 standard sizes are prepared with the maximum length 4020mm.
 While V-shaped area is heat-treated to HRC50~58, the center area is left soft so that further machining is easy such as for drilling and tapping. Connection is also possible if longer rail is necessary,

Type	Features
Guide Rail	6 standard sizes are available.
Guide Way	3 standard sizes are available in a supporting-stand shape.
Ring Guide Way	3 standard sizes in 7 types are available, as ring type of Guide Way, with standard maximum diameter 93~1033mm.

Any dust or scratch on the race surface may cause noise. Handle with care.

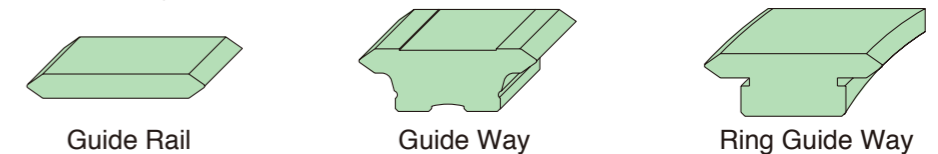

Carriage Plate

Types & applicable rail

Carriage Plate is an important part of the system, together with journal bearings and other components to be incorporated. Mounting holes for Lubricator are also pre-machined.

Type	Applicable Rail
Straight	Straight rail (Guide Rail, Guide Way)
Ring	Ring Guide Way in a fixed diameter and combination with straight guide rail (Guide Rail, Guide Way, Ring Guide Way)
Swing	For S-shaped movement on any type of rails in a fixed width (Special)

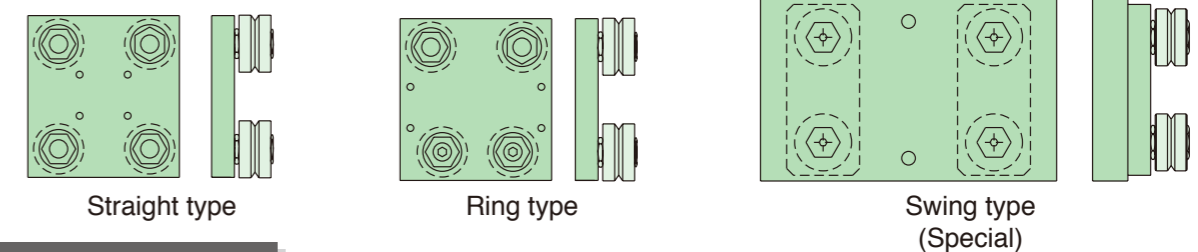

Lubricator (Optional)

Application and Features

Lubricator can be mounted with a carriage-plate to contact with the rail's V-shaped surface during running operation to feed sufficient lubricant and wipe away foreign substances, so that it increases the load carrying capacity and service life as well as the maximum speed of journal bearings. Shell Tonna Oil is the best recommended lubricant for this linear motion system.

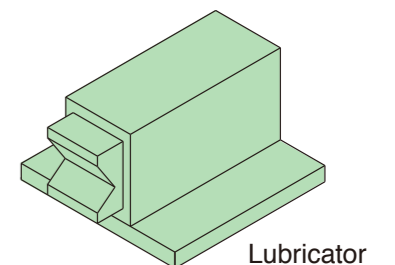

Rack (Custom-made)

Application and Features

Use together with Guide Rail or Guide Way on purpose to guide and drive the works along the straight line. Rack fixed with either Guide Rail or Guide Way makes it possible to attain compact design and cost-saving performance.



RAIL

Guide Rail · Guide Way

Material :SCM435 (Chrome molybdenum steel)
 V-shaped area hardness :HRC50~58 (High-frequency hardened)
 V-angle tolerance :70°
 Straightness :1m or less : 0.3mm 2m or less : 0.6mm 3m or less : 0.9mm 4m or less : 1.2mm
 Parallelness :1m or less : 0.3mm 2m or less : 0.6mm 3m or less : 0.9mm 4m or less : 1.2mm
 Tolerance for mounting holes' pitch :±0.2mm (Accuracy after mounting=non-accumulative)
 Roughness at V-area :Ra3.2
 Surface Treatment :Hard-Chromium-Plated

The tolerance of hole pitch is not the accumulated value, but the value between each hope pitch. Please specify proper pitch interval dimension at the time of order, or the pitch will be processed according to our standard dimension.

Ring Guide Way

Material :S45C or SCM435
 V-shaped area hardness :HRC50~58 (High-frequency hardened)
 V-angle tolerance :70°
 Tolerance of mounting hole angle :±12' (Accuracy after mounting)
 Roughness at V-area :Ra3.2
 Surface Treatment :Hard-Chromium-Plated

Parts number of the connectable Guide Rail and Guide Way carries Prefix "T-"e.g. T-AMR12XL.
 Connectable Guide Rail and Guide Way are machined to assemble in the following tolerances:

Space :0.2mm or less
 Difference in level of V-shaped surfaces :0.02mm or less
 Unit : mm

Carriage number	Parts number					
	AMP25C×255	AMP25C×351	AMP44C×468	AMP44C×612	AMP76C×799	AMP76C×1033
Width of straight rail	25		44		76	
Diameter of Ring Guide Way	255	351	468	612	799	1033
Maximum width gap between rail and journal bearing	0.18	0.09	0.21	0.21	0.13	0.19

※ Theoretical value

JOURNAL BEARING

● Standard Series

Material Ball Bearing :SUJ (bearing steel), hardness: HRC60~64
 ※SUS: AMJ 12 only
 Bearing Shield :SPCC (Shield Type)
 ※AMJ76 (Shield Type) : Rubber Seal
 Seal :NBR (Rubber Seal Type)
 Stud (Journal) :S45C
 Nut :S45C
 Washer :SS400
 Hexagonal screw :SCM435
 Lubricant :Shell Alvania Grease No.3
 Operating Temperature Range :−20°C ~ 120°C

● Stainless Series

Material Ball Bearing :SUS440C (equivalent)
 Stud, etc :SUS303, SUS304
 ※AMJ76 (Shield Type) : Rubber Seal
 Operating Temperature Range :−20°C ~ 120°C

Size number	12	25	44	76
Non re-lubricable type, m/sec.	1.5	1.5	1.5	1.5
Re-lubricable type, m/sec.	2	2	2	2

CARRIAGE PLATE

Material :Aluminum-alloy
 Surface Treatment :Black Anodic Oxide coating

※ Specifications are subject to change without prior notice.

Rail

Size number	Parts number		
	25 mm	44 mm	76 mm
Guide Rail	AMR25XL	AMR44XL	AMR76XL
	AMR25AXL	AMR44AXL	AMR76AXL
	—	—	AMR76BXL
Guide Way	AMR25WXL	AMR44WXL	AMR76WXL
	AMR25WAXL	AMR44WAXL	AMR76WAXL
Ring Guide Way	AMR25CX159(A,B,C)	AMR44CX468(A,B,C)	AMR76CX799(A,B,C)
	AMR25CX255(A,B,C)	AMR44CX612(A,B,C)	AMR76CX1033(A,B,C)
	AMR25CX351(A,B,C)		

Note: 1. Put total length of rail in place of symbol "L". (See P.14)

2. Suffixes A, B and C in the above Ring Guide Way's parts number mean the ring's arc degree; 90°, 180°, 360°.

3. See P.13 and 14 for length and other dimensions.

4. Above parts number of Guide Rail and Guide Way represent only standard series, not suitable for connection.

5. For connection application, prefix "T-" should be added to the parts number. (See page 9 thru 12)

Journal Bearings

Size number	Parts number				Fix / Adjust	Sealing
	AS12 mm	AS25 mm	AS44 mm	AS76 mm		
Short type	AMJ12C	AMJ25C	AMJ44C	AMJ76C	Fixed	Shield
	AMJ12E1	AMJ25E1	AMJ44E1	AMJ76E1	Adjustable	
	AMJ12C-UU	AMJ25C-UU	AMJ44C-UU	AMJ76C-UU	Fixed	Rubber Seal
	AMJ12E1-UU	AMJ25E1-UU	AMJ44E1-UU	AMJ76E1-UU	Adjustable	
Long type	AMJ12CL	AMJ25CL	AMJ44CL	AMJ76CL	Fixed	Shield
	AMJ12E1L	AMJ25E1L	AMJ44E1L	AMJ76E1L	Adjustable	
	AMJ12CL-UU	AMJ25CL-UU	AMJ44CL-UU	AMJ76CL-UU	Fixed	Rubber Seal
	AMJ12E1L-UU	AMJ25E1L-UU	AMJ44E1L-UU	AMJ76E1L-UU	Adjustable	
Lock-nut type	AMJ12CN	AMJ25CN	AMJ44CN	AMJ76CN	Fixed	Shield
	AMJ12E1N	AMJ25E1N	AMJ44E1N	AMJ76E1N	Adjustable	
	AMJ12CN-UU	AMJ25CN-UU	AMJ44CN-UU	AMJ76CN-UU	Fixed	Rubber Seal
	AMJ12E1N-UU	AMJ25E1N-UU	AMJ44E1N-UU	AMJ76E1N-UU	Adjustable	

Note: 1. Each Journal Bearings size number; 12mm, 25mm, 44mm, 76mm shall fit to the same size number of Carriage Plate.

※ For the rail with the width of 12mm, please consult us in advance.

2. Symbol "C" is used for fixed type, and "E1" for adjustable type.

3. Dimensions are shown on P.17.

4. Stainless series are also available. Refer to P17 for detail.

Carriage Plate

Size number	Parts number			
	12 mm	25 mm	44 mm	76 mm
Straight type	AMP12(A,B,C)	AMP25(A,B,C)	AMP44(A,B,C)	AMP76(A,B,C)
	—	AMP25A(A,B,C)	AMP44A(A,B,C)	AMP76A(A,B,C)
Ring type	—	AMP25C×159	AMP44C×468	AMP76C×799
	—	AMP25C×255	AMP44C×612	AMP76C×1033
		AMP25C×351		
Swing type (special)	—	AMS25	AMS44	AMS76

Note: 1. Dimensions are shown on P.15 and 16.

Straight type
—Motion Guide Set—

Long guide system becomes possible by connecting Guide Rail and Guide Way.

1. Maximum length per rail is 3956mm. Please connect the rails for more than maximum rail length.
2. No-mounting-hole types are prepared as: W2 and R2, if you machine mounting holes by yourselves. Please designate when ordering.

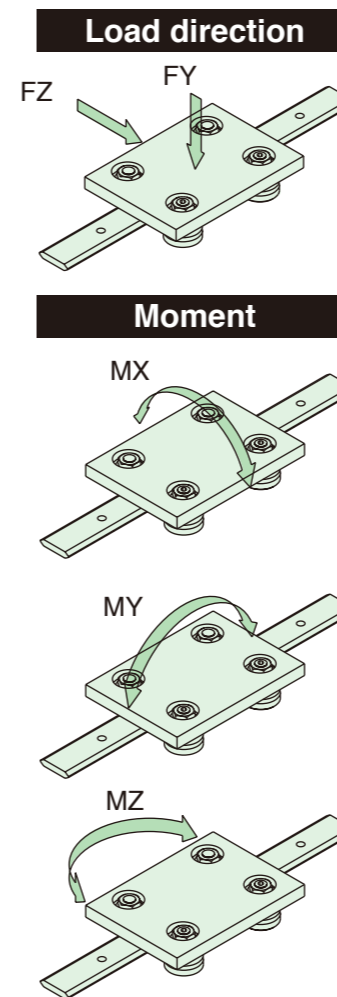
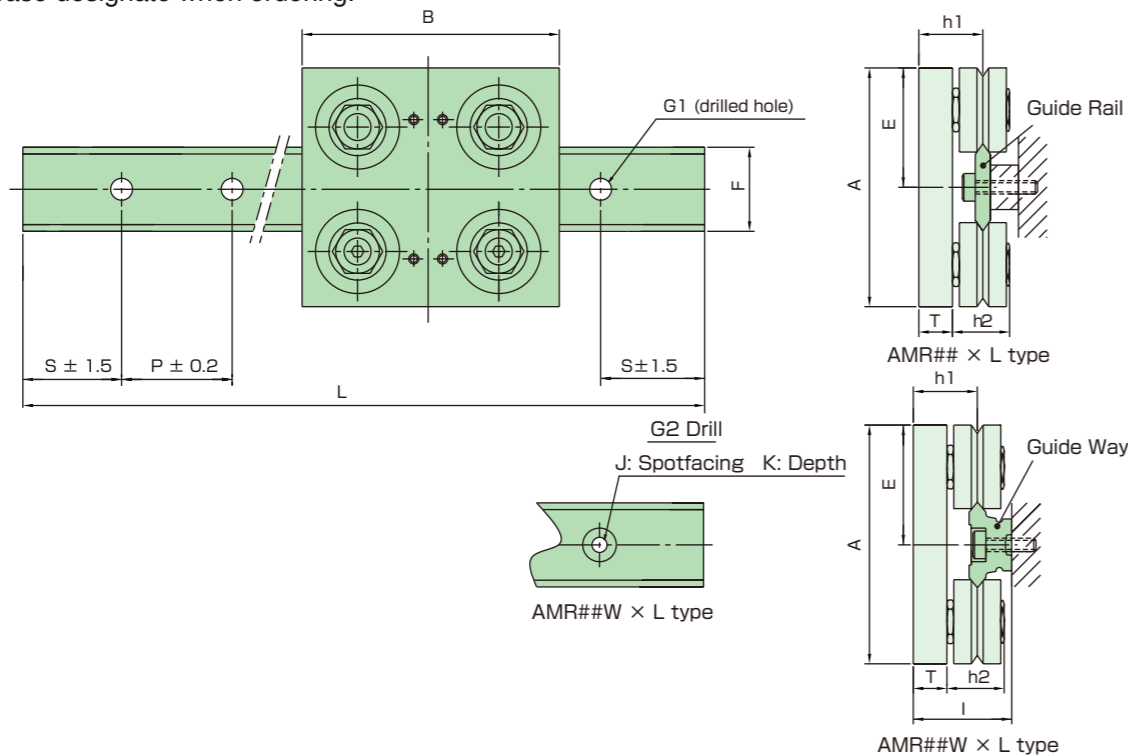

Numbering System - Straight type

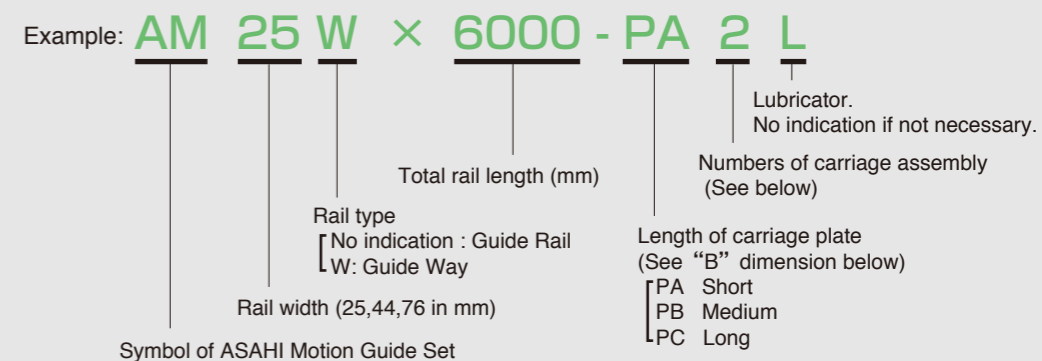

Capacity Table of Carriage assembly

Note: Carriage Assembly consists of a carriage plate and journal bearings mounted, and is shown by suffix "JX".

Carriage assembly number	Capacity					Wt. (g)
	Load capacity (N)		Moment capacity (Nm)			
	FY	FZ	MX	MY	MZ	
AMP25AJX	1764	882	22.7	44.1	22.1	190
AMP25BJX			22.7	61.7	30.9	298
AMP25CJX			22.7	105.8	52.9	406
AMP44AJX	3136	1568	112.9	133.3	66.6	638
AMP44BJX			112.9	156.8	78.4	871
AMP44CJX			112.9	235.2	117.6	1104
AMP76AJX	7056	3528	270.7	493.9	247.0	2087
AMP76BJX			270.7	705.6	352.8	2986
AMP76CJX			270.7	1058.4	529.2	3886

Straight type-Motion Guide Set

Unit : mm

Set number	Components			Dimensions														
	Guide Rail	Journal Bearings	Carriage Plate	A	B	E	F	G1	(G2)	(J)	(K)	L	S	P	h1	h2	T	(I)
AM25 × L-P(A,B,C)	AMR25 × L	AMJ25C	AMP25A	80	80	40	25	6.5	5.5	10	5.5	266~3956	43	90	19	17	10	29
AM25W × L-P(A,B,C)	T-AMR25W × L	AMJ25E1	AMP25B		130													
			AMP25C		180													
AM44 × L-P(A,B,C)	AMR44 × L	AMJ44C	AMP44A	115	125	57.5	44	6.5	7	11	6.5	266~3956	43	90	26.5	22	15	39
AM44W × L-P(A,B,C)	T-AMR44W × L	AMJ44E1	AMP44B		175													
			AMP44C		225													
AM76 × L-P(A,B,C)	AMR76 × L	AMJ76C	AMP76A	185	200	92.5	76	10.5	14	20	12.5	446~3956	43	90	37	35	18	56.5
AM76W × L-P(A,B,C)	T-AMR76W × L	AMJ76E1	AMP76B		300													
			AMP76C		400													

1. Put total length of rail in mm in place of symbol "L".
2. Suffix "A", "B" and "C" mean length of carriage plate, respectively. See dimension table on P.15 and 16.
3. Please order in mm for the length "L" within the range shown on the above table.
4. Maximum length is 4020mm for no-mounting hole types.

5. The prefix "T" means that Guide Rail/Way is already machined to be connected.
6. The dimensions (G2), (J), (K) and (I) are for Guide Way only.

Curved and Ring type for space saving to your needs !!

Track type
Motion Guide Set

Realized connection of straight rail to curved rail.

1. Maximum length per rail 3956mm.
2. No-mounting-hole types are prepared as; W2 and R2, if you machine mounting holes by yourselves. Please designate when ordering.

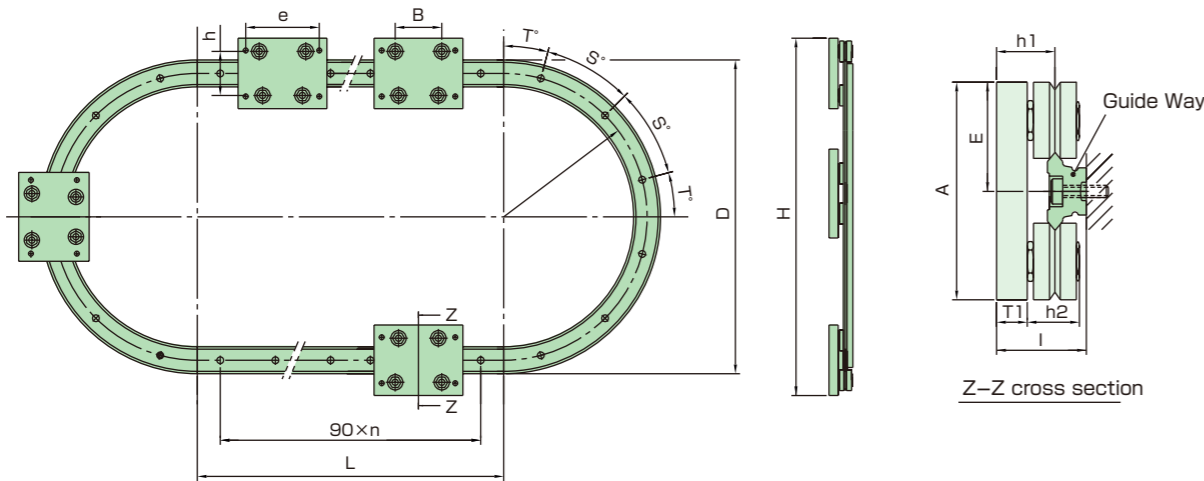

Load direction

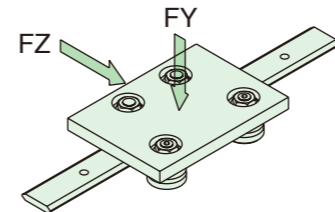

Moment

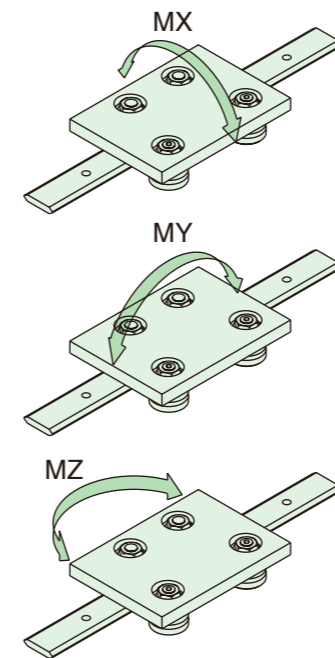

Numbering System - Track type

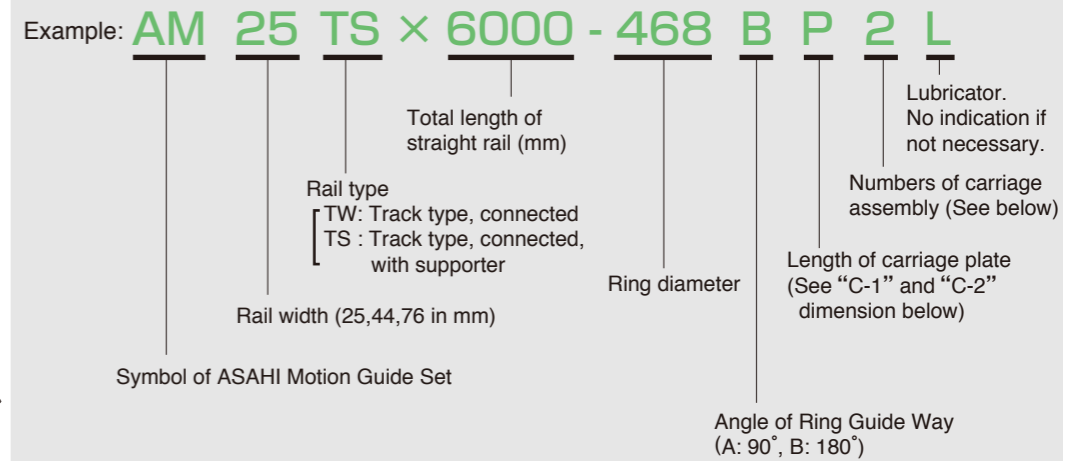

5 Capacity table of Carriage Assembly

Note: Carriage Assembly consists of a carriage plate and journal bearings mounted, and is shown by suffix "JX".

Carriage assembly number	Capacity					Wt. (g)
	Load capacity (N)		Moment capacity (Nm)			
	FY	FZ	MX	MY	MZ	
AMP25C-159JX	1764	882	22.7	41.9	20.9	222
AMP25C-255JX	1764	882	22.7	38.7	19.4	233
AMP25C-351JX	1764	882	22.7	40.3	20.2	244
AMP44C-468JX	3136	1568	70.1	119.2	59.6	688
AMP44C-612JX	3136	1568	70.1	123.6	61.8	710
AMP76C-799JX	7056	3528	270.7	369.0	184.5	1997
AMP76C-1033JX	7056	3528	270.7	435.7	217.9	2177

Track type-Motion Guide Set

Unit : mm

Set number	Components				Dimensions													
	Guide Rail	Ring Guide Way	Carriage Plate	Journal Bearings	L	D	H	e	f	S	T	A	B	E	h1	h2	T1	I
AM25TW × L-159BP(L)	T-AMR25W×L	T-AMR25C×159B	AMP25C×159	AMJ25C	266~	159	239	80	50	45	22.5	80	95	40	19.0	17	10	29
AM25TW × L-255BP(L)		T-AMR25C×255B	AMP25C×255	AMJ25E1		255	335	85		30	15		105					
AM25TW × L-351BP(L)		T-AMR25C×351B	AMP25C×351	AMJ25E1		351	431	85		30	15		105					
AM44TW × L-468BP(L)	T-AMR44W×L	T-AMR44C×468B	AMP44C×468	AMJ44C	266~	468	583	120	75	30	15	115	145	57.5	25.5	22	15	39
AM44TW × L-612BP(L)		T-AMR44C×612B	AMP44C×612	AMJ44E1		612	727	125		22.5	11.25		150					
AM76TW × L-799BP(L)	T-AMR76W×L	T-AMR76C×799B	AMP76C×799	AMJ76C	446~	799	984	160	100	22.5	11.25	185	190	92.5	37.0	35	18	56.5
AM76TW × L-1033BP(L)		T-AMR76C×1033B	AMP76C×1033	AMJ76E1		1033	1218	180		18	9		210					

- Note: 1. Put total length of rail in mm in place of symbol "L".
 2. Please consult us for other width as for Ring Guide Way.
 3. The prefix "T" means that Guide Rail/Way is already machined to be connected.



Guide Rail

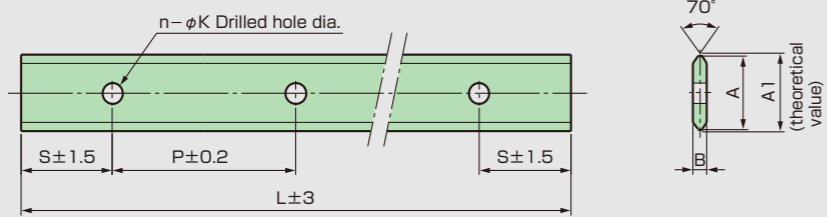

Guide Way

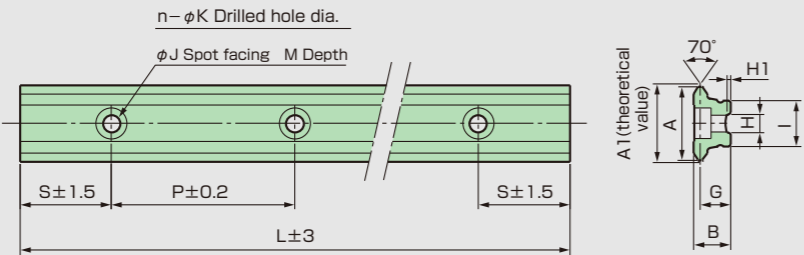

Ring Guide Way

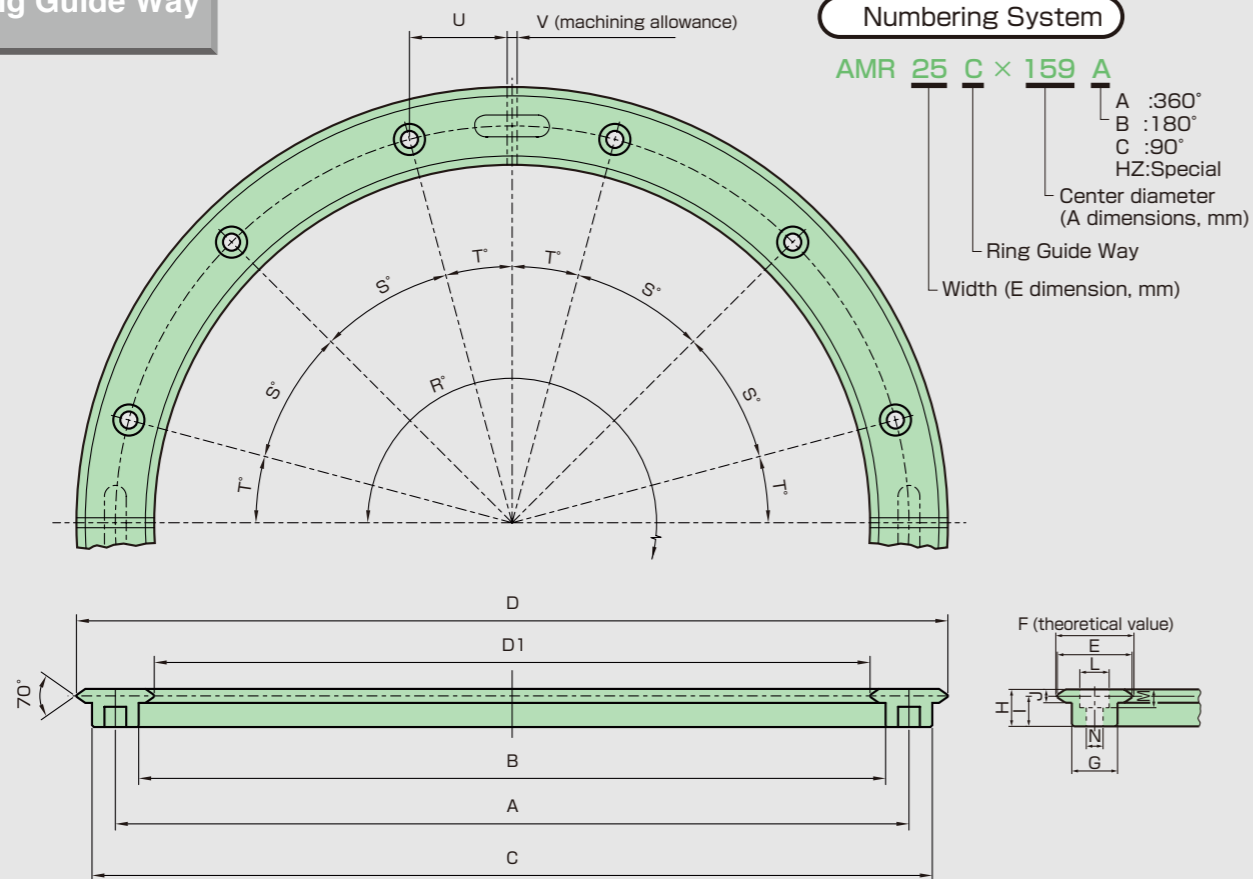

Guide Rail

Part number	Dimensions(mm)							Nos.of holes n	Mounting Bolt	Wt. kg/m
	A	A1	B	K	S	P	L			
AMR25 × L	25	25.74	4.5	6.5	43	90	See length and numbers below	M6	0.8	
AMR25A × L	25.5	26.58	5	5.5				M5	0.9	
AMR44 × L	44	44.74	6	6.5				M6	1.9	
AMR44A × L	44.5	45.88	6.5	7				M6	2.1	
AMR76 × L	76	76.74	9	10.5				M10	5	
AMR76B × L	76	76.74	6	6.5				M6	3.4	

Put length of rail in place of symbol "L".

Guide Way

Part number	Dimensions(mm)														Nos.of holes n	Mounting Bolt	Wt. kg/m
	A	A1	B	G	H	H1	I	J	K	S	P	L	M				
AMR25W × L	25	25.74	12.25	10	6	1.3	15	10	5.5	43	90	See length below	5.5	See length below	M5	1.6	
AMR44W × L	44	44.74	15.5	12.5	8	1.3	26	11	7				6.5		M6	3.7	
AMR76W × L	76	76.74	24	19.5	20	1.3	50.5	20	14				12.5		M12	10.6	

Length of rail and numbers of drilled holes, applicable to both Guide Rail and Guide Way.

Total length(mm)	176	266	356	446	536	626	716	806	896	986	1076	1166
Nos. of holes n	2	3	4	5	6	7	8	9	10	11	12	13
Total length(mm)	1256	1346	1436	1526	1616	1706	1796	1886	1976	2066	2156	2246
Nos. of holes n	14	15	16	17	18	19	20	21	22	23	24	25
Total length(mm)	2336	2426	2516	2606	2696	2786	2876	2966	3056	3146	3236	3326
Nos. of holes n	26	27	28	29	30	31	32	33	34	35	36	37
Total length(mm)	3416	3506	3596	3686	3776	3866	3956					
Nos. of holes n	38	39	40	41	42	43	44					

Maximum length available is 4020 mm if tapped hole not necessary.

Ring Guide Way Dimensions

Part number	Dimensions(mm)														Nos.of holes R=360°	Wt. kg R=360°							
	A±0.2	D	D1	E	F theoretical value	G	H	I	J	L	N	R'	S'±0.2	U			V						
AMR25C×159(A,B,C)	159	184	134	25	25.74	15.4	12.25	10	4.5	9.5	5.5	90	180	360	45	22.5	29.4	1	8	0.77			
AMR25C×255(A,B,C)	255	280	230												47.8	1.2							
AMR25C×351(A,B,C)	351	376	326												44.4	1.65							
AMR44C×468(A,B,C)	468	512	424	44	44.74	26	15.5	12.5	6	11	6.8				90	180	360	30	15	58.6	2	16	5.1
AMR44C×612(A,B,C)	612	656	568															57.7	6.7				
AMR76C×799(A,B,C)	799	875	723	76	76.74	50.5	24	19.5	9	20	14							90	180	360	22.5	11.25	75.9
AMR76C×1033(A,B,C)	1033	1109	957									78.8	32										

The (A, B, C) shows the angles of cut-off Ring Guide Way. A:360° B:180° C:90°



Straight Type

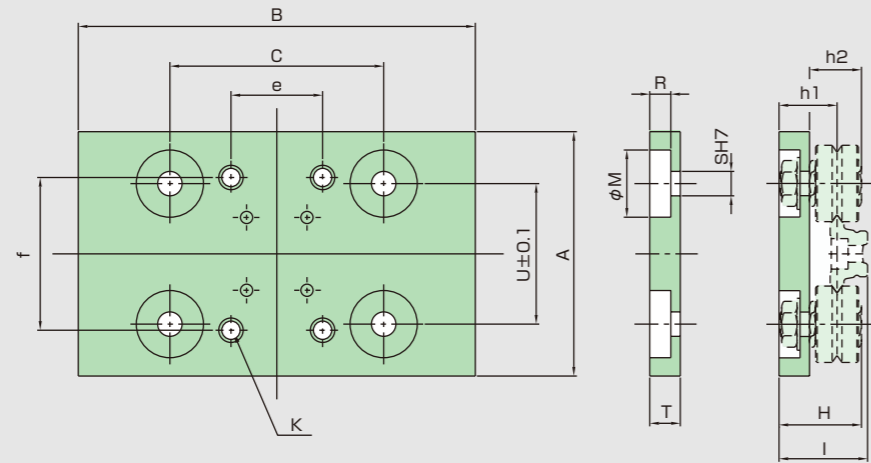

Ring Type

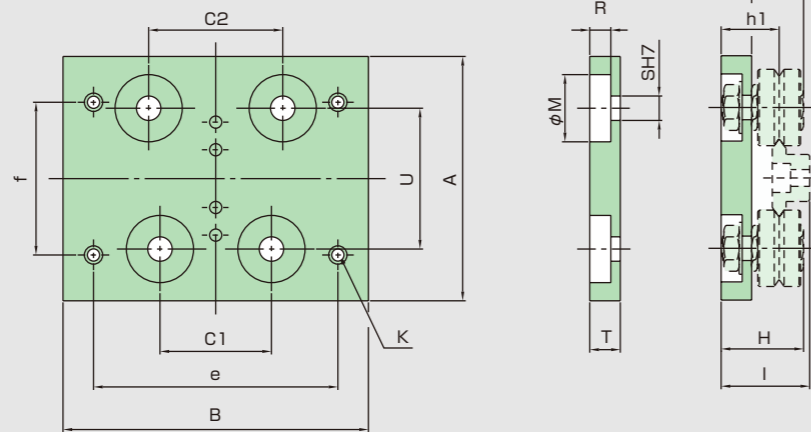

Swing Type (Special)

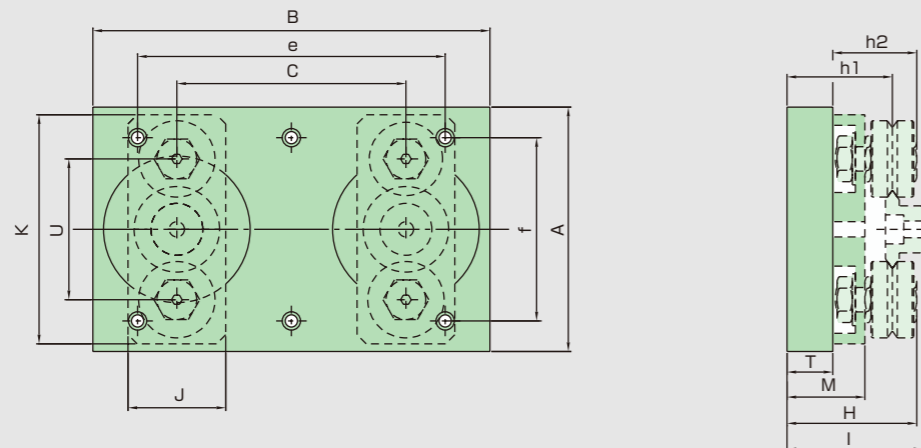

■ Straight type Carriage Plate

Unit : mm

Part number	Journal Bearings applicable	Rail applicable	Dimensions														Wt. (g)	
			U±0.1	C	A	B	T	R	M	S	f	e	K	H	I	h1		h2
AMP12A	AMJ12	AMR12×L	22	35	40	50	6	3.5	12.5	4	25	—	M4	16.5	—	11.5	10.5	27
AMP12B				60		75						25						
AMP12C				85		100						50						
AMP25A	AMJ25	AMR25×L	46	50	80	80	10	6.9	22	8	50	18	M6	27	29	19	17	140
AMP25B		70		130		30						248						
AMP25C		120		180		50						356						
AMP44A	AMJ44	AMR44×L	72	85	115	125	15	8.5	25	10	75	48	M8	37	39	26.5	22	523
AMP44B		100		175		50						756						
AMP44C		150		225		50						989						
AMP76A	AMJ76	AMR76×L	119	140	185	200	18	11.5	32	14	125	60	M10	53	—	37	35	1,672
AMP76B				200		300						80						2,571
AMP76C				300		400						180						3,471
AMP25AA	AMJ25	AMR25A×L	47	50	80	80	10	6.9	22	8	50	18	M6	27	29	19	17	140
AMP25AB		70		130		30						248						
AMP25AC		120		180		50						356						
AMP44AA	AMJ44	AMR44A×L	73	85	115	125	15	8.5	25	10	75	48	M8	37	39	26.5	22	523
AMP44AB		100		175		50						756						
AMP44AC		150		225		50						989						

Note: 1. Put length of rail in place of symbol "L".
2. AMP 76 (A,B,C) is applicable also to Guide Rail AMR76BxL. See table on P.14.

■ Ring type Carriage Plate

Unit : mm

Part number	Journal Bearings applicable	Ring Guide Way applicable	Dimensions														Wt. (g)		
			U	C1	C2	A	B	T	R	M	S	f	e	K	H	I		h1	h2
AMP25C-159	AMJ25	AMR25C×159(A,B,C)	46.1	35	47.5	80	95	10	6.9	22	8	50	80	M6	27	29	19	17	172
AMP25C-255		36.5		43.9	100		183												
AMP25C-351		40		45.7	105		194												
AMP44C-468	AMJ44	AMR44C×468(A,B,C)	71.9	65	76.0	115	145	15	8.5	25	10	75	120	M8	36	38	25.5	22	573
AMP44C-612		70		78.8	150		595												
AMP76C-799	AMJ76	AMR76C×799(A,B,C)	118.7	90	104.6	185	190	18	11.5	32	14	100	160	M10	53	56.5	37	35	1,582
AMP76C-1033		110		123.5	210		1,762												

■ Swing type Carriage Plate (Special)

Unit : mm

Part number	Journal Bearings applicable	Rail applicable	Dimensions											Wt. (g)			
			B	A	H	I	U	C	e	f	K	f	K		T	M	h1
AMS25	AMJ25	AMR25	130	80	42.5	42.5	46.1	75.0	90.0	60.0	M6×1	32	75	15	25.5	34.5	0.8
AMS44	AMJ44	AMR44	175	115	54.5	54.5	71.9	105.0	125.0	85.0	M8×1.25	38	105	18	32.5	44.0	2.1
AMS76	AMJ76	AMR76	240	185	77.2	77.5	118.7	130.0	175.0	125.0	M10×1.5	50	170	25	42.5	61.5	6.3

Note: Swing type carriage plate is applicable to S-shaped curve and track type system in combination with different curve diameters. This is also suitable when much stable travel performance is required.

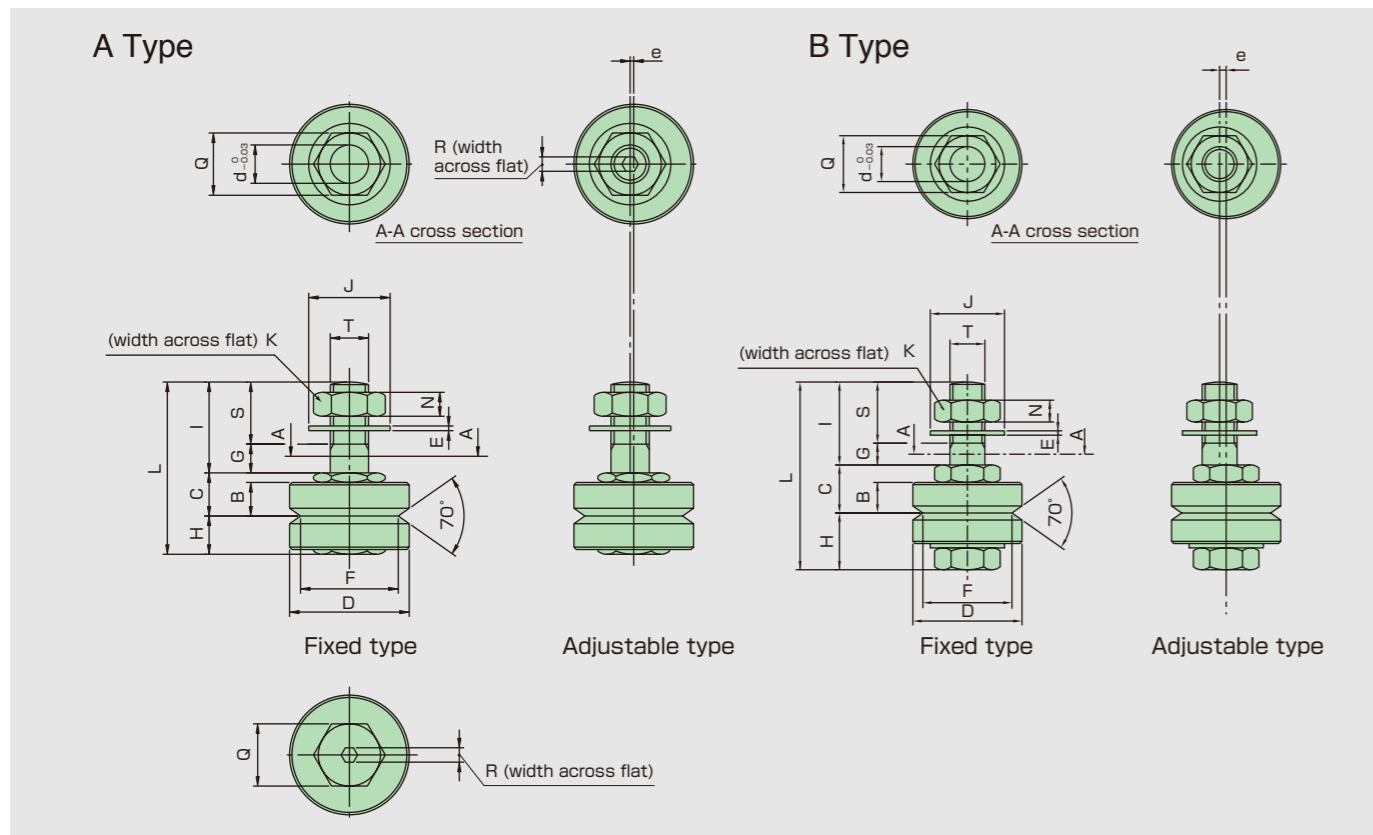

Journal Bearings Dimensions

Journal No.		Type	Dimensions(mm)																	Wt. (g)	Max. Allowable Load (N)	Tightening Torque (Ncm)			
Standard Series	Stainless Series		L	B	C	H	I	D	F*	d	T	S	G	Q	E	J	N	K	P	R	e				
AMJ12C	*S-AMJ12C	A	16.5	4	5.5±0.2	5	6	13	9.63	4	M4x0.5	3.5	2.5	8	0.8	9	2.4	7	-	-	0	0	8	98	166
AMJ12E1	*S-AMJ12E																				0.5(1.3)	0.5(1.3)			
AMJ12CL	*S-AMJ12CL		20	4	5.5±0.2	5	9.5	13	9.63	4	M4x0.5	7	2.5	8	0.8	9	2.4	7	-	-	0	0			
AMJ12E1L	*S-AMJ12EL																				0.5(1.3)	0.5(1.3)			
AMJ12CN	-	B	22	4	7.13	7.2	8	13	9.63	4	M4x0.7	4.8	3.2	8	0.8	9	3	8	-	-	0	0	11	98	147
AMJ12E1N	-																				0.5	0.5			
AMJ25C	S-AMJ25C	A	27	7	9±0.2	8	10	25	20.4	8	M8x1.0	6.5	3.5	13	1.0	17	5	13	3	-	0	0	50	441	1293
AMJ25E1	S-AMJ25E																				3	0.75(2.0)			
AMJ25CL	S-AMJ25CL		36	7	9±0.2	8	19	25	20.4	8	M8x1.0	13	6	13	1.0	17	5	13	3	-	0	0			
AMJ25E1L	S-AMJ25EL																				3	0.75(2.0)			
AMJ25CN	-	B	43	7	11	13	19	25	20.4	8	M8x1.0	14	5	13	1.0	17	5	13	-	-	0	0	60	441	1294
AMJ25E1N	-																				1.5	1.5			
AMJ44C	S-AMJ44C	A	36	9	11.5±0.2	11	14	34	27.17	10	M10x1.25	8	6	17	1.2	21	6	17	4	-	0	0	115	784	2508
AMJ44E1	S-AMJ44E																				4	1.0(2.5)			
AMJ44CL	S-AMJ44CL		44	9	11.5±0.2	11	22	34	27.17	10	M10x1.25	15	7	17	1.2	21	6	17	4	-	0	0			
AMJ44E1L	S-AMJ44EL																				4	1.0(2.5)			
AMJ44CN	-	B	52	9	13	18	21	34	27.17	10	M10x1.25	15	6	17	1.2	21	6	17	-	-	0	0	140	784	2538
AMJ44E1N	-																				1.5	1.5			
AMJ76C	S-AMJ76C	A	53	14	19±0.2	16	18	54	42	14	M14x1.5	11	7	27	1.5	28	8	22	8	-	0	0	415	1764	7134
AMJ76E1	S-AMJ76E																				6	1.5(4.5)			
AMJ76CL	S-AMJ76CL		65	14	19±0.2	16	30	54	42	14	M14x1.5	21	9	27	1.5	28	8	22	8	-	0	0			
AMJ76E1L	S-AMJ76EL																				6	1.5(4.5)			
AMJ76CN	-	B	74	14	22	24	28	54	42	14	M14x1.5	17	11	27	1.5	28	8	22	-	-	0	0	550	1764	7134
AMJ76E1N	-																				2.7	2.7			

Note: 1. Please consult us for the bigger eccentricity. (See "e" dimension)
 2. "F#a" is diameter of V-contacting points.
 3. The figures in () of the "e" dimension are for stainless steel journal bearing.
 4. Journal bearing with seals is also available. For order, please add suffix "UU".
 5. * Please consult us.

Covered in shock-resistant plastic case, Lubricator has oil-contained felt wiper, which spreads lubricant film on V-shaped surface of Guide Rail. This also prevents wear of rail, and significantly increases load capacity and life of the system.

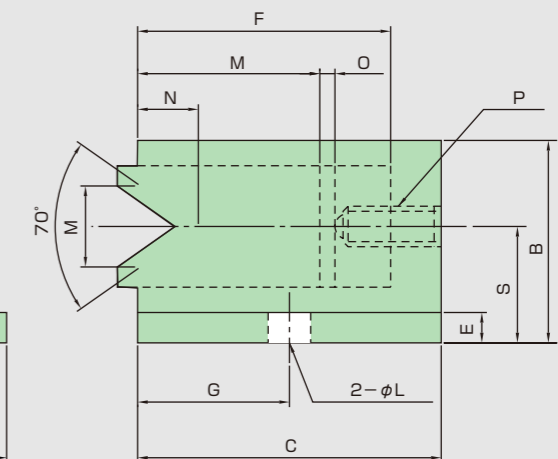
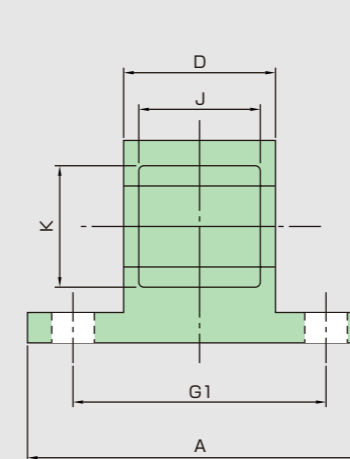
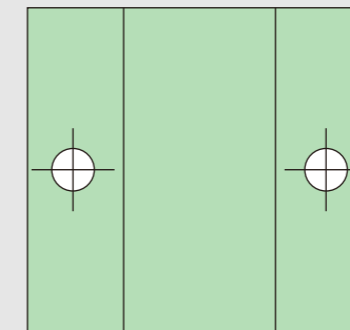

Lubricator for straight rail

Unit : mm

Part number	Application		Dimensions															
	Journal bearing	Rail	A	B	C	D	E	F	G	G1	H	J	K	L	M	N	O	P
AML25F	AMJ25C(L)	AMR25	25	16.5	25	10	2	20	12.5	18	6	7	7	3.2	16	5	1	M4
	AMJ25E1(L)																	
AML44F	AMJ44C(L)	AMR44	34	20	30	15	2.4	25	15	25	8	12	12	4.2	18	6	1	M4
	AMJ44E1(L)																	
AML76F	AMJ76C(L)	AMR76	50	33.5	55	22	4.5	45	27.5	38	10	18	18	5.2	30	11	1	M4
	AMJ76E1(L)																	

Note: Lubricator for Ring Guide is also available. Please consult us.

Assembly Manual

1. Journal Bearings to Carriage Plate

As shown on a sketch below, please mount fixed types (AMJ##C) Journal Bearings to one side of Carriage plate, and adjustable types (AMJ##E1, or AM##E) to the other, following the direction of rail. In case of Ring type carriage plate, the fixed type bearings should be mounted to the side where mounting-hole distance is shorter.

2. Mounting to rail

1. Journal bearings AMJ##E1 type (with smaller eccentricity)

Carriage Assembly shall be mounted from the end of rail.

2. Journal bearings AMJ##E type (with bigger eccentricity)

Carriage Assembly can be mounted either from the upside of the rail or if possible from the end of rail.

- Note: 1 please do not put any overstress when mounting.
 2 In case of Guide Way, please choose either side of supporting portion as datum face, and set the fixed type bearings at the datum-face side.

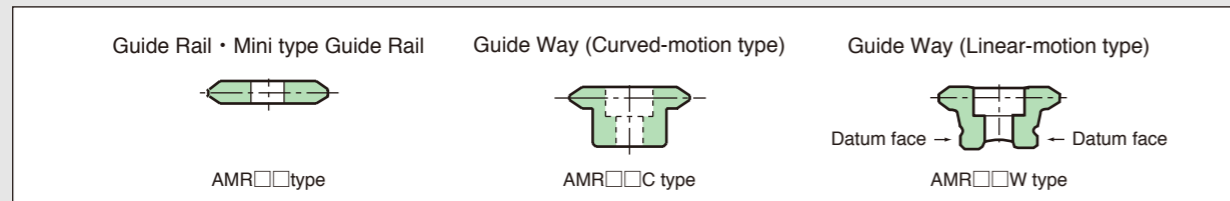
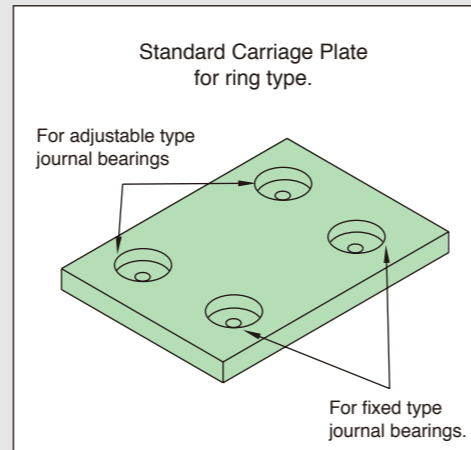

3. Clearance between Journal Bearings and Rail

Please adjust by using the following portion:

Short type AMJ##E1/E, Long type AMJ##E1L/EL:

Adjust a hexagonal nut at stud neck by spanner.

Or, adjust hexagonal key socket either at the tail of stud or at bearing head by key socket wrench.

Lock-nut type AMJ##EN:

Adjust a hexagonal nut at stud neck by spanner.

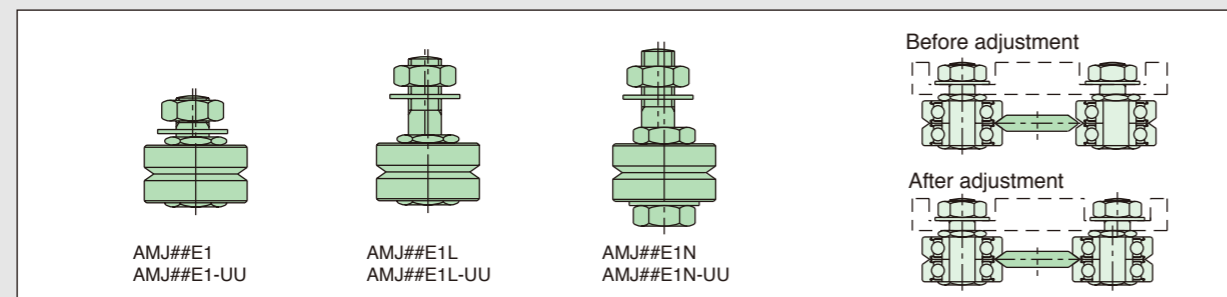

4. Components of Motion Guide Systems

Motion Guide Systems are composed of various combinations between rail and appropriate carriage plate.

5. Careful attention to adjustment

Standard carriage assembly

Please fix a carriage plate and rotate only journal bearings by hands, and adjust to the extent where there causes a slight slipping resistance. After then, please adjust to the condition where moving power becomes the recommended value shown below, by putting load by push-pull gauge to the running direction of carriage plate.

Before that, please ensure the clearance between rail and all 4 bearings is zero. Appropriate pre-load applied by fastening adjustable bearings leads to "no-clearance" status and provides more rigidity of the system. However, over pre-load may cause decreasing service life of the bearings, so please pay careful attention.

Recommended pre-load by push-pull gauge			
Journal bearing size	Pre-load(N)	Journal bearing size	Pre-load(N)
AMJ12	3.2	AMJ44	8
AMJ25	4	AMJ76	12

Swing carriage assembly

Swing carriage assembly will be supplied after mounting and adjusting bearings to carriage plate at our factory.

N.B.

By request, mounting and adjustment will be done at our factory before delivery if a set of journal bearings, carriage plates and rails are ordered.

Please joint by the following procedures.

- 1) Provisionally fasten the rail fixing screws at the both end of joining rails.
- 2) Fit the attached key with factory-signed marks in a right position properly.
- 3) Put the attached springs and flat head screws as illustrated and fix the key.
- 4) Then, firmly fix the provisionally fastened rail fixing screws on both sides.

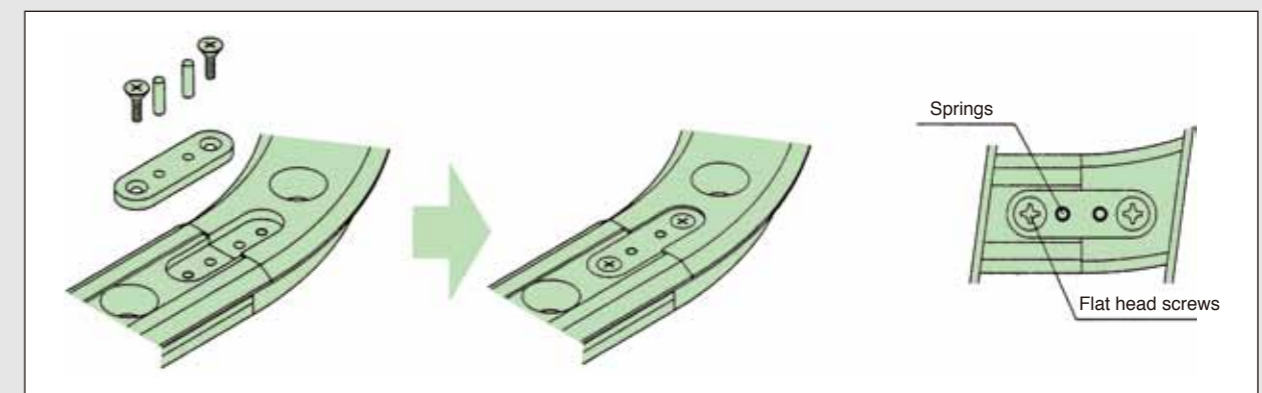

- By request, the joint and adjustment will be done at our factory as long as there is no problem in packaging and transportation.



- Load capacity of the Motion Guide System varies by such as position of center of works' gravity, position of driving force, speed changes for start and stop, and other effects. For selection, please calculate load capacity in consideration of these factors as necessary.

W : Load on the system (N)
 P_r : Radial load on journal bearings (N)
 P_{rT} : Thrust load on journal bearings (N)

<p>Example 1</p>	$P_1 = \frac{W}{4} + \frac{W}{2} \times \frac{l_2}{l_0} - \frac{W}{2} \times \frac{l_3}{l_1}$ $P_2 = \frac{W}{4} - \frac{W}{2} \times \frac{l_2}{l_0} - \frac{W}{2} \times \frac{l_3}{l_1}$ $P_3 = \frac{W}{4} - \frac{W}{2} \times \frac{l_2}{l_0} + \frac{W}{2} \times \frac{l_3}{l_1}$ $P_4 = \frac{W}{4} + \frac{W}{2} \times \frac{l_2}{l_0} + \frac{W}{2} \times \frac{l_3}{l_1}$
<p>Example 2</p>	$P_1 = \frac{W}{4} + \frac{W}{2} \times \frac{l_2}{l_0} - \frac{W}{2} \times \frac{l_3}{l_1}$ $P_2 = \frac{W}{4} - \frac{W}{2} \times \frac{l_2}{l_0} - \frac{W}{2} \times \frac{l_3}{l_1}$ $P_3 = \frac{W}{4} - \frac{W}{2} \times \frac{l_2}{l_0} + \frac{W}{2} \times \frac{l_3}{l_1}$ $P_4 = \frac{W}{4} + \frac{W}{2} \times \frac{l_2}{l_0} + \frac{W}{2} \times \frac{l_3}{l_1}$
<p>Example 3</p>	$P_1 = P_3 = \frac{W}{4} - \frac{R}{2} \times \frac{l_2}{l_0}$ $P_2 = P_4 = \frac{W}{4} + \frac{R}{2} \times \frac{l_2}{l_0}$

<p>Example 4</p>	$P_1 = P_2 = -\frac{W}{2} \times \frac{l_3}{l_1}$ $P_3 = P_4 = \frac{W}{2} \times \frac{l_3}{l_1}$ $l_2 \geq \frac{l_0}{2} \quad l_2 < \frac{l_0}{2}$ $P_{1T} = \frac{W}{2} + W \times \frac{l_2}{l_0} \quad P_{1T} = \frac{W}{2} + W \times \frac{l_2}{l_0}$ $P_{3T} = \frac{W}{2} - W \times \frac{l_2}{l_0} \quad P_{2T} = \frac{W}{2} - W \times \frac{l_2}{l_0}$ $P_{2T} = P_{4T} = 0 \quad P_{3T} = P_{4T} = 0$
<p>Example 5</p>	$P_1 = P_2 = P_3 = P_4 = \frac{W}{2} \times \frac{l_2}{l_0}$ $l_3 \geq \frac{l_1}{2} \quad l_3 < \frac{l_1}{2}$ $P_{2T} = \frac{l_3}{l_0} W + \frac{l_1}{l_0} \times \frac{W}{2} \quad P_{1T} = P_{2T} = P_{3T} = P_{4T} = 0$ $P_{3T} = \frac{l_3}{l_0} W - \frac{l_1}{l_0} \times \frac{W}{2}$ $P_{1T} = P_{4T} = 0$
<p>Example 6</p>	<p>When accelerating</p> $P_1 = P_4 = \frac{W}{4} - \frac{W}{2} \times \frac{1}{g} \times \frac{V_1}{t_1} \times \frac{l_2}{l_0}$ $P_2 = P_3 = \frac{W}{4} + \frac{W}{2} \times \frac{1}{g} \times \frac{V_1}{t_1} \times \frac{l_2}{l_0}$ <p>When at even speed</p> $P_{1T} = P_{2T} = P_{3T} = P_{4T} = \frac{W}{4}$ <p>When slowing down</p> $P_1 = P_4 = \frac{W}{4} + \frac{W}{2} \times \frac{1}{g} \times \frac{V_1}{t_1} \times \frac{l_2}{l_0}$ $P_2 = P_3 = \frac{W}{4} - \frac{W}{2} \times \frac{1}{g} \times \frac{V_1}{t_1} \times \frac{l_2}{l_0}$

1 kgf = 9.8 N



- Load capacity of the Motion Guide System varies by such as position of center of works' gravity, position of driving force, speed changes for start and stop, and other effects. For selection, please calculate load capacity in consideration of these factors as necessary.

W : Load on the system (N)
 P_n : Radial load on journal bearings (N)
 P_{nT} : Thrust load on journal bearings (N)

Example 1 (See example of P.21)

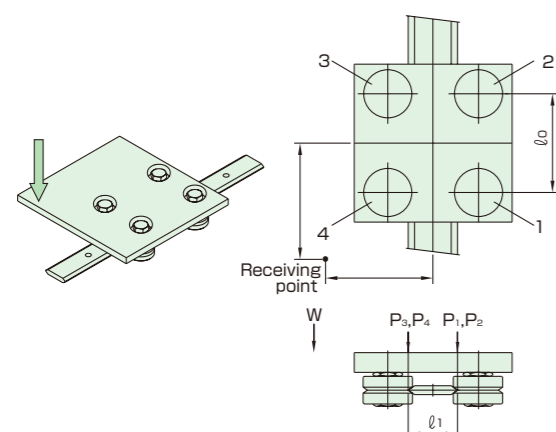

$$P_1 = \frac{W}{4} + \frac{W}{2} \times \frac{l_2}{l_0} - \frac{W}{2} \times \frac{l_3}{l_1}$$

$$P_2 = \frac{W}{4} + \frac{W}{2} \times \frac{l_2}{l_0} - \frac{W}{2} \times \frac{l_3}{l_1}$$

$$P_3 = \frac{W}{4} - \frac{W}{2} \times \frac{l_2}{l_0} + \frac{W}{2} \times \frac{l_3}{l_1}$$

$$P_4 = \frac{W}{4} - \frac{W}{2} \times \frac{l_2}{l_0} + \frac{W}{2} \times \frac{l_3}{l_1}$$

Where: Journal bearings AMJ44type
 Guide Rail AMR44type
 W = 196N, l₀=85mm, l₁=44mm

■ Calculation Example

l₂ = 20 mm, l₃ = 20 mm

$$P_1 = \frac{196}{4} + \frac{196}{2} \times \frac{20}{85} - \frac{196}{2} \times \frac{20}{44} = 27.51 \quad P_3 = \frac{196}{4} - \frac{196}{2} \times \frac{20}{85} + \frac{196}{2} \times \frac{20}{44} = 27.51$$

$$P_2 = \frac{196}{4} - \frac{196}{2} \times \frac{20}{85} - \frac{196}{2} \times \frac{20}{44} = -18.60 \quad P_4 = \frac{196}{4} + \frac{196}{2} \times \frac{20}{85} + \frac{196}{2} \times \frac{20}{44} = 116.60$$

Maximum load capacity in this case is found as 116.62N on P₄, and its life L_s as 296 km as per Life Chart.

Therefore, its life will be approx. 3 years time-wise in case stroke length 2,000 mm, 100 strokes per day and 250 days operation per year.

- Actual life varies with various factors of application.
- Life of grease inside the journal varies depending on the status of the installed journal.
- Better efficiency of lubrication can be expected by spreading grease on V-shaped tracks of journals and the guide rail.
- Life gets shorter when one stroke of the system is shorter than one rotation of journal bearing.

■ Approximate Life of Motion Guide System can be obtained from the Life Chart below.

Life Chart
(In case of no relubrication)

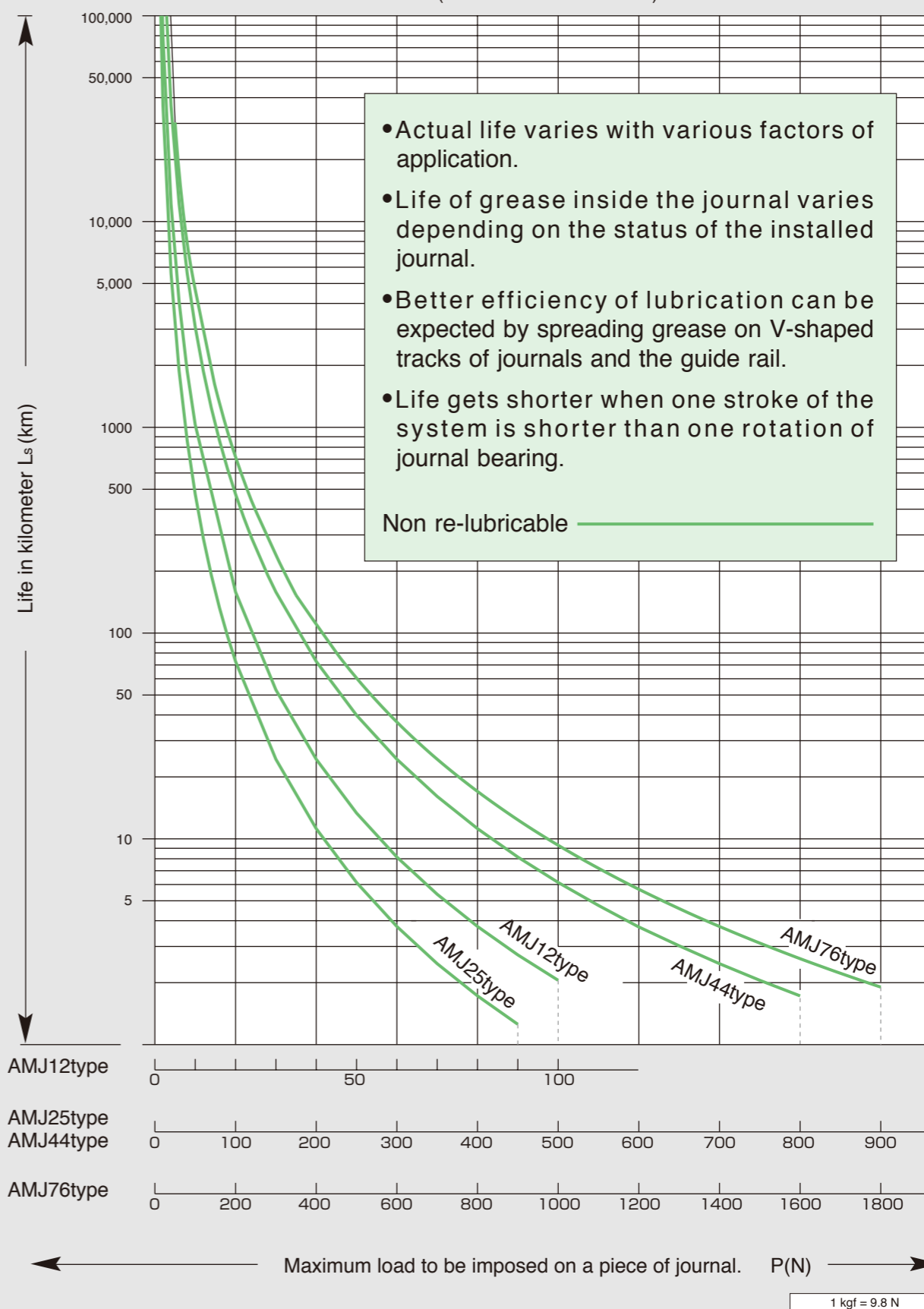

The combination of Guide Rail/Way, Ring Guide Way and standard / special Carriage Plate can make Motion Guide Systems.

For linear motion

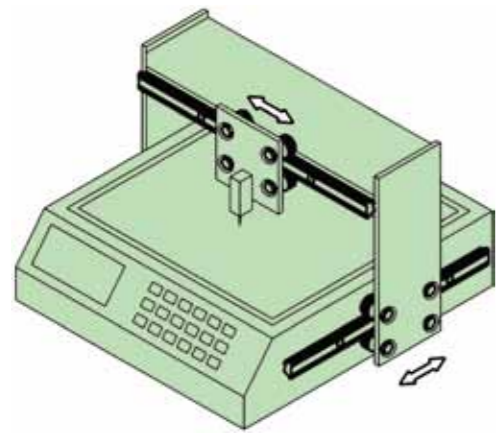

For linear motion racks on Guide Rail

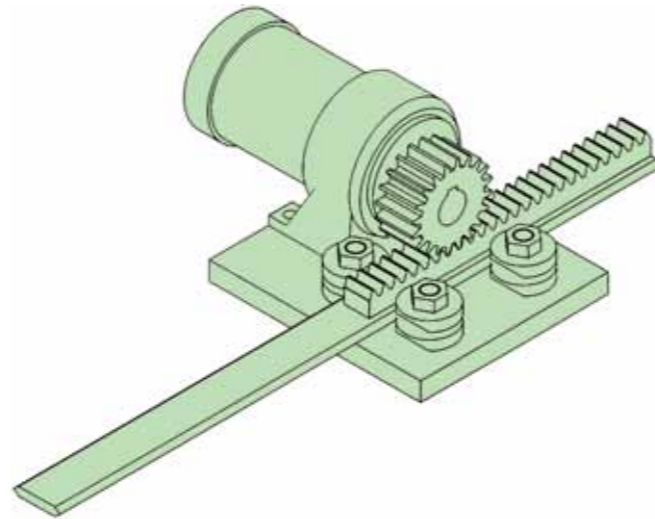

For vertical linear motion with racks on a pair of Guide Rails

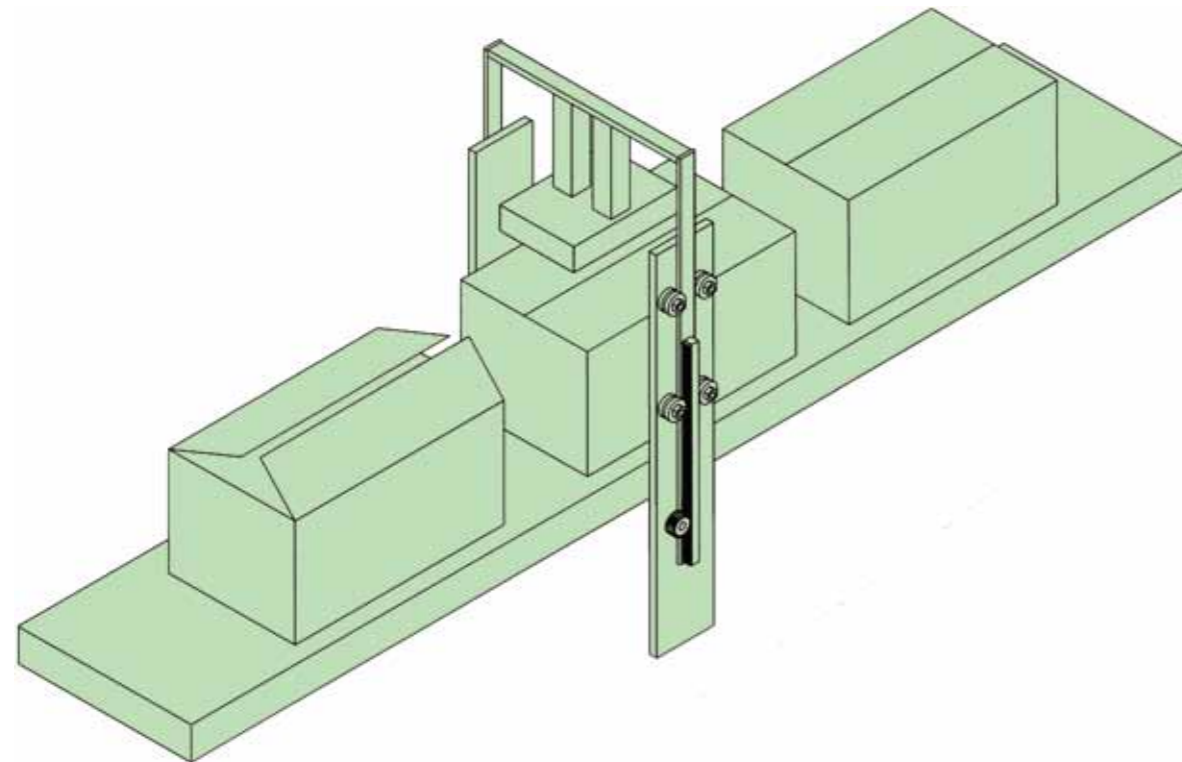

For linear motion of a table on Guide Rail with racks underneath

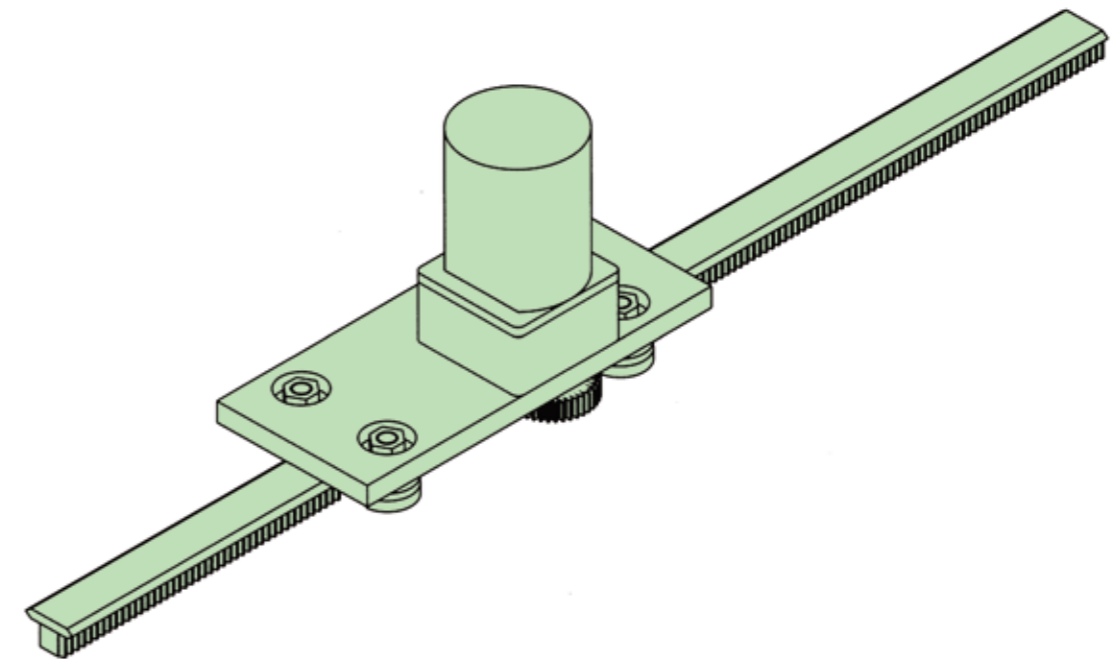

Track systems driven by chain

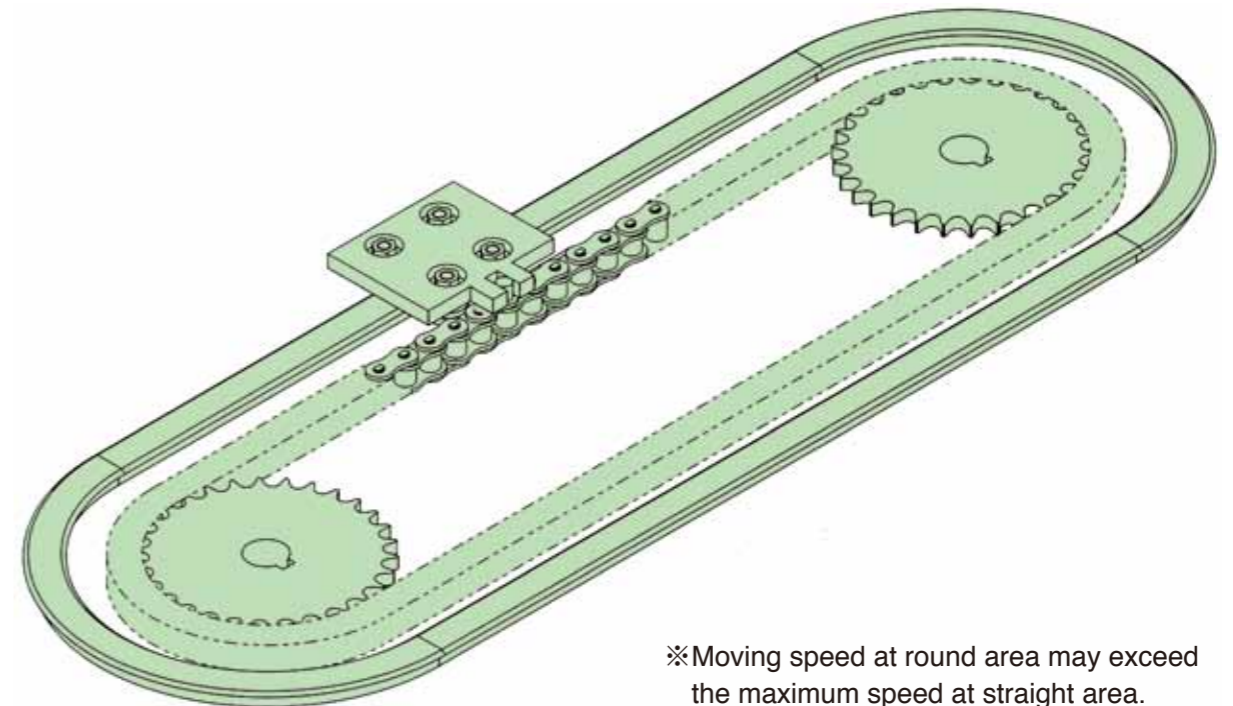

※Moving speed at round area may exceed the maximum speed at straight area.