

*Paragon Semiconductor Lighting Technology*

*PSLT*

**ParagonLED**

## Specifications

**Product Type : CDLC-42-30135-120V-30**

**Issued Date : 10/10/2016**

Paragon Semiconductor Lighting Technology Co., Ltd.  
Headquarters: 3F., No.369, Sec. 2, Wenhua 2nd Rd., Linkou Dist., New Taipei City 244, Taiwan (R.O.C.)  
TEL: +886-2-2602-1066      FAX: 886-2-2601-0508

# Contents

## 1. General Description

1-1 Naming Rule

1-2 Outline dimensions

## 2. Electro-optical characteristics

2-1 Absolute Maximum Rating

2-2 Electro-optical characteristics

2-3 Graphs

2-4 Layout

## 3. Junction Temperature measurement

## 4. Reliability Test

# 1. General Description

## (1) Naming rule

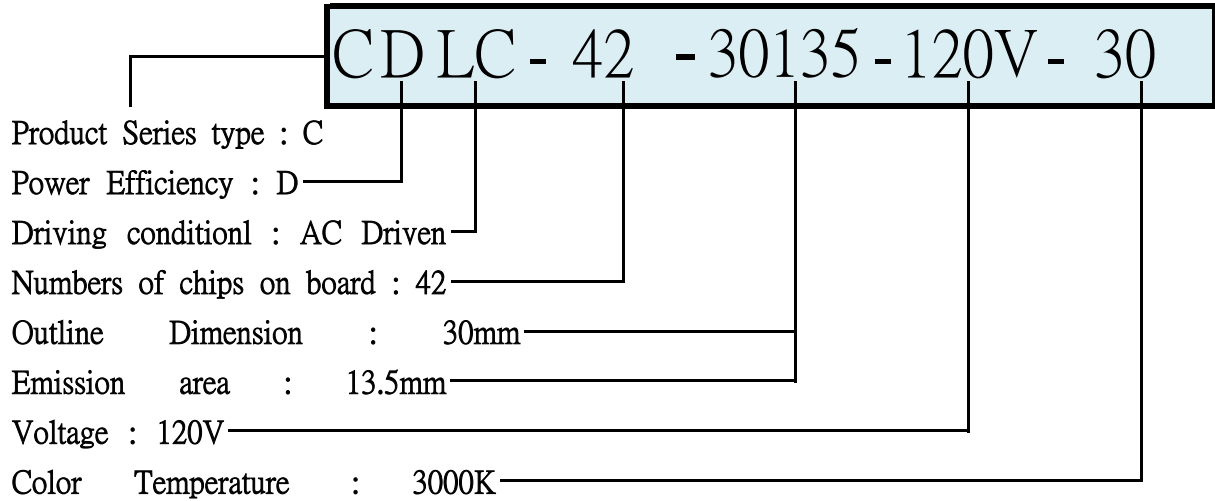

## (2) Outline Dimensions (Unit : mm / Tolerance: 0.2mm)

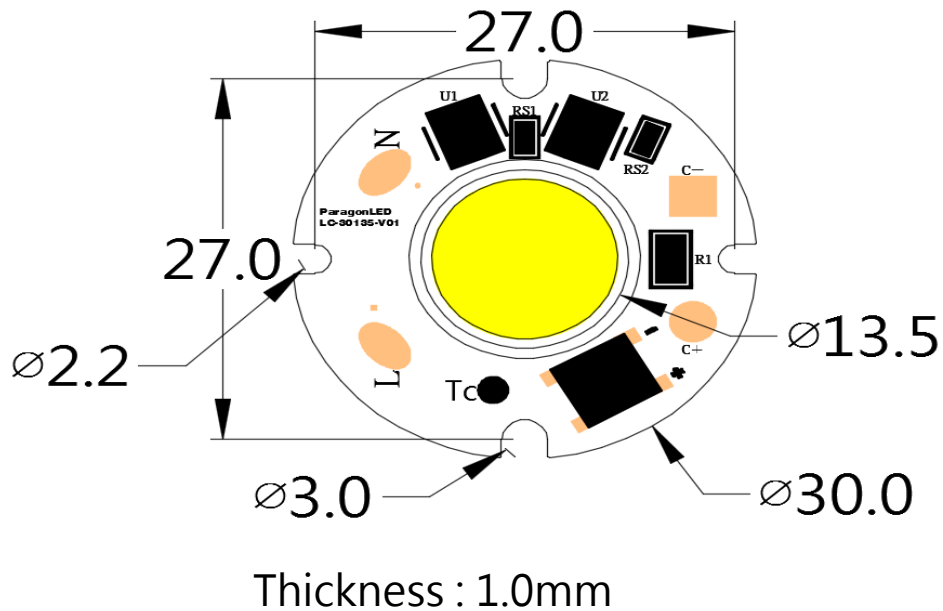

# 2. Electro-Optical Characteristics

## (1) Absolute Maximum Rating

| Parameter                    | Symbol | Value           | Unit |
|------------------------------|--------|-----------------|------|
| Power Dissipation            | PD     | 16              | W    |
| Forward Current              | IF     | -               | mA   |
| Forward Voltage              | VF     | 110 ~ 140       | V    |
| Operating Temperature        | Topr   | -60 ~ +105      | °C   |
| Storage Temperature          | Tstg   | -60 ~ +105      | °C   |
| Assembly process temperature | Tsol   | <300°C , 5 secs |      |

## (2) Electro-Optical Characteristics

| Parameter          | Symbol   | Condition | Min | Typ  | Max | Unit |
|--------------------|----------|-----------|-----|------|-----|------|
| Forward Voltage    | VF       | -         | 110 | 120  | 140 | V    |
| Percent Flicker    |          | -         | -   | -    | 30  | %    |
| Luminous Intensity | $\Phi_v$ | VF=120V   | -   | 1152 | -   | Lm   |
| Color rendering    | Ra       | VF=120V   | 90  | -    | -   |      |

**Notice: Operating voltage of CDLC-042 product varies from 110V~140V · users must keep the temperature of solder joint point under 105°C (with suitable heat sink), or may cause Serious luminous decay. We DO NOT guarantee of improper use.**

## (3) Characteristics

### Spectrum

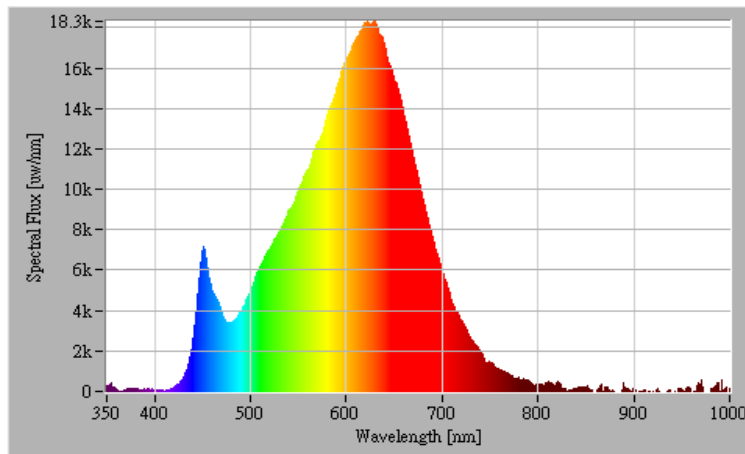

### Candle Power Distribution & Cartesian Coordinate

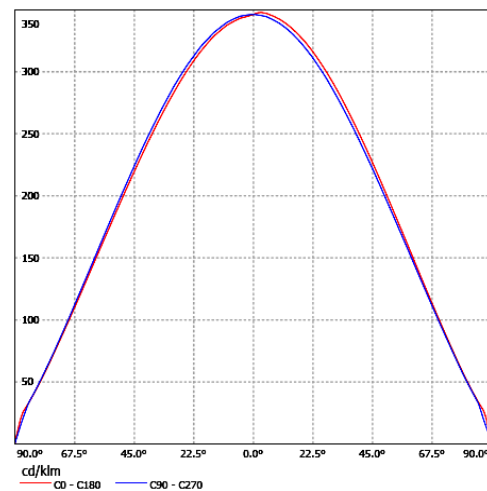
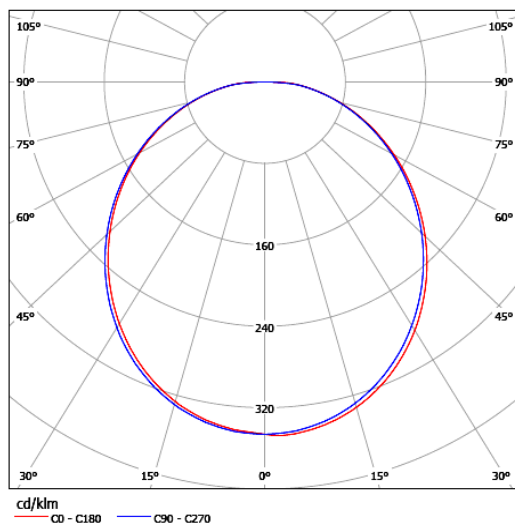

#### (4) Layout

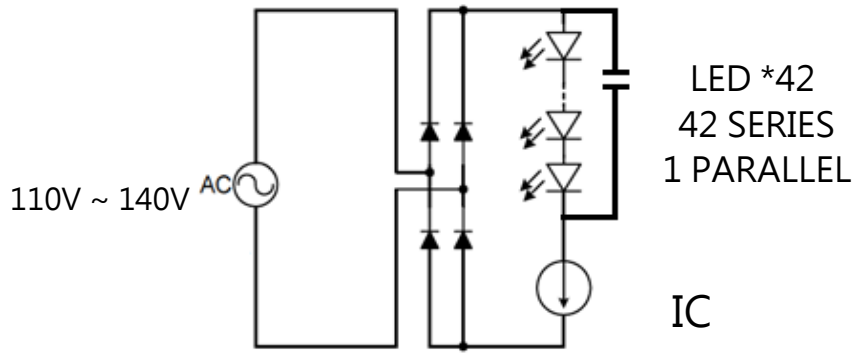

### 3. Junction Temperature Measurement

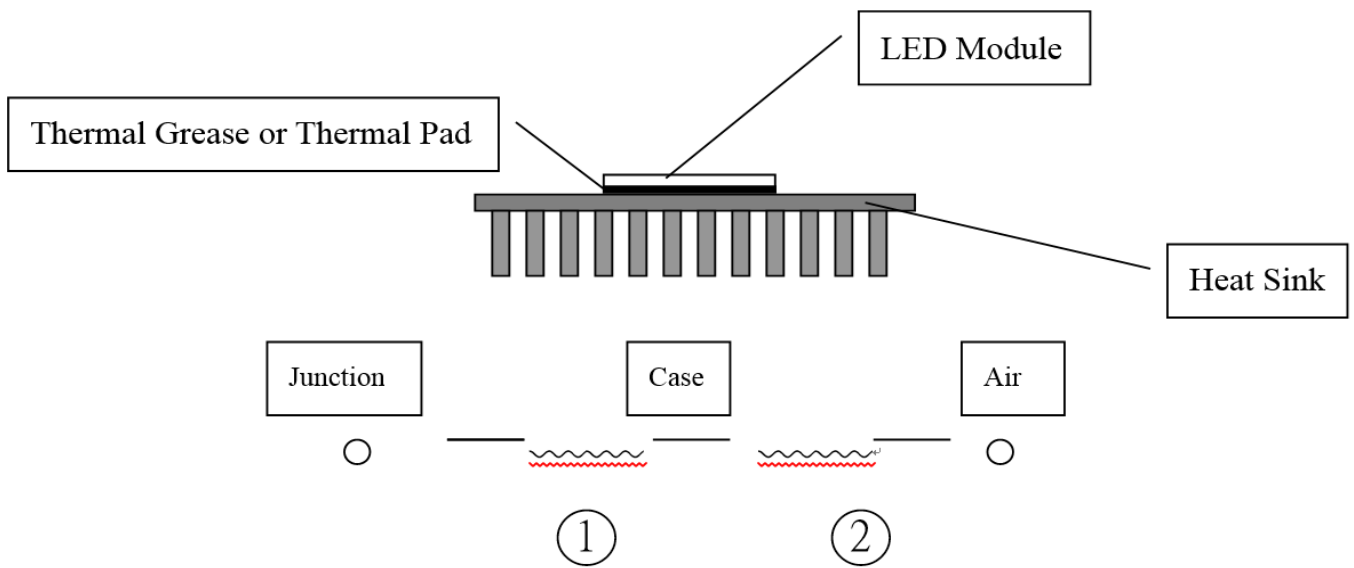

- ① Thermal resistance of Junction to Case without heat sink :  $10(^{\circ}\text{C}/\text{W})$  [ Reference Value ]
- ② Thermal resistance of Case to Ambient Air: Depending on what kind of heat sink users choose. In ideal thermal dissipation situation, the thermal resistance is about  $1\sim 2^{\circ}\text{C}/\text{W}$ .

## 4. Reliability Test

| Test Item                     | Test Conditions                         | Number of failed |
|-------------------------------|---|------------------|
| High Temperature Storage Test | Tstg= +105°C , x1,000 hrs               | 0/20             |
| Low Temperature Storage Test  | Tstg=-40°C , x1,000 hrs                 | 0/20             |
| Continous Light-on Test       | Ta= 25°C , RH=65% , x1,000 hrs          | 0/20             |
| Boiling Test                  | Ta=100°C , RH=100% , X180mins           | 0/20             |
| Thermal Cycle Test            | - 40°Cx30mins , 80°Cx30mins , 100cycles | 0/20             |

| Measuring Item      | Measuring Condition | Judging Criteria of Failure |
|---------------------|---------------------|-----------------------------|
| Forward Voltage     | VF=120V             | > 0 x 1.1                   |
| Total Luminous Flux | VF=120V             | < L x 0.85                  |

***Dielectric Breakdown Voltage (Vac) of Thermal Pad must >4 KV***

***WARNING : Please ground lighting fixtures while designing lamps.  
If any damage or defect of LED caused without grounding, we do not guarantee of improper use.***