

PRESSURE TRANSMITTER

DATA SHEET

FKG...5

The FCX-AIII pressure transmitter accurately measures gauge pressure and transmits a proportional 4 to 20mA signal.

The transmitter utilizes a unique micromachined capacitance silicon sensor with state-of-the-art microprocessor technology to provide exceptional performance and functionality.

FEATURES

- High accuracy up to ±0.04%**
0.065% accuracy as standard, 0.04% accuracy as option. Fuji's micro-capacitance silicon sensor assures this accuracy for all elevated or suppressed calibration ranges without additional adjustment.
- Minimum environmental influence**
The "Advance Floating Cell" design which protects the pressure sensor against changes in temperature, and overpressure substantially reduces total measurement error in actual field applications.
- Fuji/HART® bilingual communications protocol and FOUNDATION™ fieldbus and Profibus™ compatibility**
FCX-AIII series transmitter offers bilingual communications to speak both Fuji proprietary protocol and HART®. Any HART® compatible devices can communicate with FCX-AIII. Further, by upgrading electronics FOUNDATION™ fieldbus and Profibus™ are also available.
- Application flexibility**
Various options that render the FCX-AIII suitable for almost any process applications include:
 - Full range of hazardous area approvals
 - Built-in RFI filter and lightning arrester
 - 5-digit LCD meter with engineering unit
 - Stainless steel electronics housing
- Burnout current flexibility (Under Scale: 3.2 to 4.0mA, Over Scale: 20.0 to 21.6mA)**
Burnout signal level is adjustable using Model FXW Hand Held Communicator (HHC) to comply with NAMUR NE43.
- Dry calibration without reference pressure**
Thanks to the best combination of unique construction of mechanical parts (Sensor unit) and high performance electronics circuit (Electronics unit), reliability of dry calibration without reference pressure is at equal level as wet calibration.



SPECIFICATIONS

Functional specifications

Service: Liquid, gas, or vapour

Span, range and overrange limit:

Type	Span limit [kPa] {bar}		Range limit [kPa] {bar}		Overrange limit [MPa] {bar}
	Min.	Max.	Lower limit	Upper limit	
FKG□01	1.3 {0.013}	130 {1.3}	-100 {-1}	130 {1.3}	1 {10}
FKG□02	5 {0.05}	500 {5}	-100 {-1}	500 {5}	1.5 {15}
FKG□03	30 {0.3}	3000 {30}	-100 {-1}	3000 {30}	9 {90}
FKG□04	100 {1}	10000 {100}	-100 {-1}	10000 {100}	15 {150}
FKG□05	500 {5}	50000 {500}	-100 {-1}	50000 {500}	75 {750}

Remark: To minimize environmental influence, span should be greater than 1/40 of the max. span in most applications.

- Lower range limit (vacuum limit) ;
Silicone fill sensor: See Fig. 1
Fluorinated fill sensor: 66kPa abs (500mmHg abs) at below 60°C
- Conversion factors to different units;
1 MPa=10³ kPa=10bar=10.19716kgf/cm²= 145.0377psi
1kPa=10mbar=101.9716mmH₂O =4.01463inH₂O

Output signal: 4 to 20mA DC with digital signal superimposed on the 4 to 20mA signal.

Power supply: Transmitter operates on 10.5V to 45V DC at transmitter terminals.
10.5V to 32V DC for the units with optional arrester.

Load limitations: see figure below

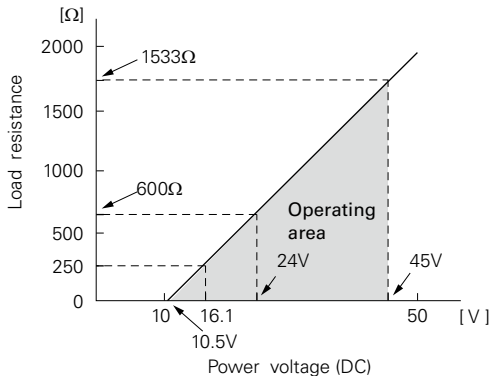

Note: For communication with HHC⁽¹⁾ (Model: FXW), min. of 250 Ω required.

Hazardous locations: (Under an application) SEE TABLE2
Zero/span adjustment:

Zero and span are adjustable from the HHC⁽¹⁾. Zero and span are also adjustable externally from the adjustment screw (span adjustment is not available with 9th digit code "L, P, Q, S").

Damping: Adjustable from HHC or local configurator unit with LCD display.
The time constant is adjustable between 0.06 to 32 seconds.

Zero elevation/suppression: Zero can be elevated or suppressed within the specified range limit of each sensor model.

Normal/reverse action: Selectable from HHC⁽¹⁾.

Indication: Analog indicator or 5-digit LCD meter, as specified.

Burnout direction: Selectable from HHC⁽¹⁾
If self-diagnostic detect transmitter failure, the analog signal will be driven to either "Output Hold", "Output Overscale" or "Output Underscale" modes.

"Output Hold": Output signal is hold as the value just before failure happens.

"Output Overscale": Adjustable within the range 20.0mA to 21.6mA from HHC⁽¹⁾

"Output Underscale": Adjustable within the range 3.2mA to 4.0mA from HHC

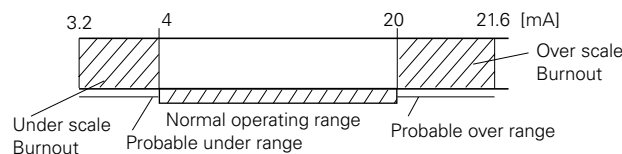

Output limits conforming to NAMUR NE43 by order.

Loop-check output: Transmitter can be configured to provide constant signal 3.2mA through 21.6mA by HHC.

Temperature limit:
Ambient: -40 to +85°C
(-20 to +80°C for LCD indicator)
(-40 to +60°C for arrester option)
(-10 to +60°C for fluorinated oil fill transmitter)
For explosionproof units (flameproof or intrinsic safety), ambient temperature must be within the limits specified by each standard.
Process: -40 to +100°C for silicone fill sensor
-20 to +80°C for fluorinated oil fill sensor
Storage: -40 to +90°C

Humidity limit: 0 to 100% RH
Communication: With HHC⁽¹⁾ (Model FXW, consult Data Sheet No. EDS8-47), following items can be remotely displayed or configured.
Note: HHC's version must be higher than 7.0 (or FXW □□□□1-□4), for FCX-AIII.

Local configurator with LCD display (option): Local configurator with 3 push button and LCD display can support following items.

Items	By communication with FXW		By local configurator (with 3 push button)	
	Display	Set	Display	Set
Tag No.	✓	✓	✓	✓
Model No.	✓	✓	✓	✓
Serial No. & Software Version	✓	—	✓	—
Engineering unit	✓	✓	✓	✓
Range limit	✓	—	✓	—
Measuring range	✓	✓	✓	✓
Damping	✓	✓	✓	✓
Output mode	✓	—	✓	—
Burnout direction	✓	✓	✓	✓
Calibration	✓	✓	✓	✓
Output adjust	—	✓	—	✓
Data	✓	—	✓	—
Self diagnoses	✓	—	✓	—
Printer (In case of FXW with printer option)	✓	—	—	—
External switch lock	✓	✓	✓	✓
Transmitter display	✓	✓	✓	✓
Linearize	✓	✓	—	—
Rerange	✓	✓	✓	✓
Saturate current	✓	✓	✓	✓
Write protect	✓	✓	✓	✓
History				
- Calibration history	✓	✓	✓	✓
- Ambient temperature history	✓	—	✓	—

EMC Conformity: EN61326-1: 2006 CE

(Note) (1) HHC: Hand Held Communicator

Performance specifications

Reference conditions, silicone oil fill, 316SS isolating diaphragms, 4 to 20mA analog output in linear mode.

Accuracy rating: (including linearity, hysteresis, and repeatability)

Max span below 10000kPa model:

For spans greater than 1/10 of URL:
 $\pm 0.065\%$ of span or
 $\pm 0.04\%$ of span (21th digit: H)

For spans below 1/10 of URL:
 $\pm \left(0.015 + 0.05 \frac{0.1 \times \text{URL}}{\text{Span}} \right) \%$ of span

Max span 50000kPa model:

For spans greater than 1/10 of URL: $\pm 0.1\%$ of span
 For spans below 1/10 of URL:

$\pm \left(0.05 + 0.05 \frac{0.1 \times \text{URL}}{\text{Span}} \right) \%$ of span

Stability: $\pm 0.1\%$ of upper range limit (URL) for 10 years.

Temperature effect:

Effects per 28°C change between the limits of -40°C and +85°C

Zero shift: $\pm (0.075 + 0.0125 \frac{\text{URL}}{\text{span}}) \%$

Total effect: $\pm (0.095 + 0.0125 \frac{\text{URL}}{\text{span}}) \%$

Overrange effect: Zero shift; 0.2% of URL for any over-range to maximum limit

Supply voltage effect:

Less than 0.005% of calibrated span per 1V

Update rate: 60 msec

Step response: Time constant: 0.08s (at 23°C)
 Dead time: approximately 0.12s
 (without electrical damping)

Mounting position effect:

Zero shift, less than 0.1kPa (1m bar) for a 10° tilt in any plane.

No effect on span. This error can be corrected by adjusting Zero.

Dielectric strength:

500V AC, 50/60Hz 1 min., between circuit and earth.

Insulation resistance:

More than 100MΩ at 500V DC.

Internal resistance for external field indicator:

12Ω or less

Physical specifications

Electrical connections:

G1/2, 1/2-14 NPT, Pg13.5, or M20 × 1.5 conduit, as specified.

Process connections:

1/4-18 NPT or Rc1/4 on 54mm centers, as specified.

Meet DIN 19213

Process-wetted parts material:

Material code (7th digit in Code symbols)	Process cover	Diaphragm	Wetted sensor body	Vent/drain
V	316 stainless steel(*1)	316L stainless steel	316 stainless steel	316 stainless steel
W	316 stainless steel(*1)	Hastelloy-C	316 stainless steel	316 stainless steel
J	316 stainless steel(*1)	316L stainless steel +Au coating	316 stainless steel	316 stainless steel
H	316 stainless steel(*1)	Hastelloy-C	Hastelloy-C lining	316 stainless steel
M	316 stainless steel(*1)	Monel	Monel lining	316 stainless steel
T	316 stainless steel(*1)	Tantalum	Tantalum lining	316 stainless steel
B	Hastelloy-C lining	Hastelloy-C	Hastelloy-C lining	Hastelloy-C
L	Monel lining	Monel	Monel lining	Monel
U	Tantalum lining	Tantalum	Tantalum lining	Hastelloy-C

Note: *(1) ASTM CF8M

Remark: Availability of above material design depends on ranges. Refer to "Code symbols".

Non-wetted parts material:

Electronics housing: Low copper die-cast aluminum alloy finished with polyester coating (standard), or 316 stainless steel (SCS14 per JIS G5121), as specified.

Bolts and nuts: Cr-Mo alloy (standard), 304 or 316 stainless steel (630 stainless steel for 50MPa unit).

Fill fluid: Silicone oil (standard) or fluorinated oil

Mounting bracket: 304 or 316 stainless steel

Environmental protection:

IEC IP67 and NEMA 6/6P

Mounting:

On 60.5mm (JIS 50A) pipe using mounting bracket, direct wall mounting, or direct process mounting.

Mass {weight}:

Transmitter approximately 2.9 to 3.4kg without options.

Add; 0.5kg for mounting bracket
 4.5kg for stainless steel housing option

Optional features

- Indicator:** A plug-in analog indicator (2.5% accuracy)
An optional 5-digit LCD meter with engineering unit is also available.
- Local configurator with LCD display:**
An optional 5 digits LCD meter with 3 push buttons can support items as using communication with FXW.
- Arrester:** A built-in arrester protects the electronics from lightning surges.
Lightning surge immunity:
4kV (1.2 × 50µs)
- Oxygen service:** Special cleaning procedures are followed throughout the process to maintain all process wetted parts oil-free.
The fill fluid is fluorinated oil.
- Chlorine service:** The fill fluid is fluorinated oil.
- Degreasing:** Process-wetted parts are cleaned, but the fill fluid is standard silicone oil. Not for use on oxygen or chlorine measurement.
- NACE specification:**
Metallic materials for all pressure boundary parts comply with NACE MR-01-75. ASTM B7M or L7M bolts and 2HM nuts (Class II) are available.
- Vacuum service:** Special silicone oil and filling procedure are applied.
See Fig.1.
- Optional tag plate:**
An extra stainless steel tag with customer tag data is wired to the transmitter.
- Coating of cell:** Cell's surface is finished with epoxy/polyurethane double coating. Specify if environment is extremely corrosive.

ACCESSORIES

- Oval flanges:** (Model FFP, refer to Data Sheet No. EDS6-128)
Converts process connection to 1/2-14 NPT or to Rc1/2; in carbon steel or in 316 stainless steel.
- Hand-held communicator:**
(Model FXW, refer to Data Sheet No. EDS8-47)

ORDERING INFORMATION

When ordering this instrument, specify.

1. CODE SYMBOLS
2. Measuring range
3. Output orientation (burnout direction) when abnormality is occurred in the transmitter.
Hold/Overscale/Overscale
Unless otherwise specified, output hold function is supplied.
4. Indication method (indicated value and unit) in case of the actual scale (code D,H,P,S on 9th digit).
5. Tag No.(up to 14 alphanumeric characters), if required.

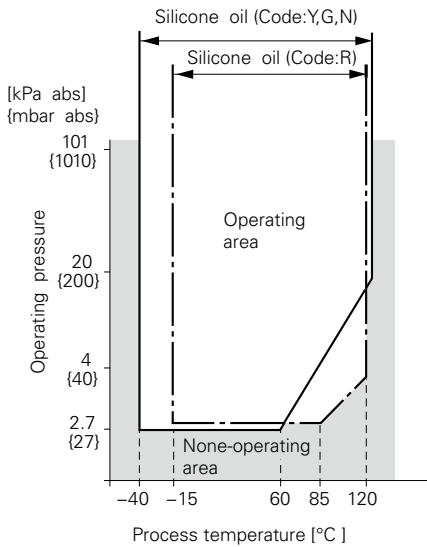

Fig. 1 Relation between process temperature and operating pressure

CODE SYMBOLS

Digit	Description				Note	1	2	3	4	5	6	7	8	9	10	11	12	13	14	15	21	← Digit No. of code
4	<Connections>					F	K	G	0	5												
	Process connection	Oval flange screw	Conduit connection	Case type																		
	Rc1/4	7/16-20UNF	G1/2	T type							5											
	1/4-18NPT	7/16-20UNF	1/2-14NPT	T type							6											
	1/4-18NPT	M10 (or M12)(*1)	Pg13.5	T type	Note 1						7											
	1/4-18NPT	M10 (or M12)(*1)	M20x1.5	T type	Note 1						8											
	1/4-18NPT	7/16-20UNF	Pg13.5	T type							9											
	Rc1/4	7/16-20UNF	G1/2	L type							S											
	1/4-18NPT	7/16-20UNF	1/2-14NPT	L type							T											
	1/4-18NPT	M10 (or M12)(*1)	Pg13.5	L type	Note 1						V											
	1/4-18NPT	M10 (or M12)(*1)	M20x1.5	L type	Note 1						W											
	1/4-18NPT	7/16-20UNF	Pg13.5	L type							X											
6, 7					Note 2																	
	Span limit [kPa]{bar}{*2}	Process cover	Diaphragm	Wetted cell body																		
	1.3...130 {0.013...1.3}	316 stainless steel	316L stainless steel	316 stainless steel																		1V
		316 stainless steel	Hast. C	SUS316																		1W
		316 stainless steel	316L stainless steel	316 stainless steel																		1J
			+Au coating																			
		316 stainless steel	Hast. C	Hast. C lining																		1H
		316 stainless steel	Monel	Monel lining																		1M
		316 stainless steel	Tantalum	Tantalum lining																		1T
		Hast. C lining	Hast. C	Hast. C lining																		1B
		Monel lining	Monel	Monel lining																		1L
		Tantalum lining	Tantalum	Tantalum lining																		1U
	5...500 {0.05...5}	316 stainless steel	316L stainless steel	316 stainless steel																		2V
		316 stainless steel	Hast. C	SUS316																		2W
		316 stainless steel	316L stainless steel	316 stainless steel																		2J
			+Au coating																			
		316 stainless steel	Hast. C	Hast. C lining																		2H
		316 stainless steel	Monel	Monel lining																		2M
		316 stainless steel	Tantalum	Tantalum lining																		2T
		Hast. C lining	Hast. C	Hast. C lining																		2B
		Monel lining	Monel	Monel lining																		2L
		Tantalum lining	Tantalum	Tantalum lining																		2U
	30...3000 {0.3...30}	316 stainless steel	316L stainless steel	316 stainless steel																		3V
		316 stainless steel	Hast. C	SUS316																		3W
		316 stainless steel	316L stainless steel	316 stainless steel																		3J
			+Au coating																			
		316 stainless steel	Hast. C	Hast. C lining																		3H
		316 stainless steel	Monel	Monel lining																		3M
		316 stainless steel	Tantalum	Tantalum lining																		3T
		Hast. C lining	Hast. C	Hast. C lining																		3B
		Monel lining	Monel	Monel lining																		3L
		Tantalum lining	Tantalum	Tantalum lining																		3U
	100...10000 {1...100}	316 stainless steel	316L stainless steel	316 stainless steel																		4V
		316 stainless steel	Hast. C	SUS316																		4W
		316 stainless steel	316L stainless steel	316 stainless steel																		4J
			+Au coating																			
		316 stainless steel	Hast. C	Hast. C lining																		4H
		316 stainless steel	Monel	Monel lining																		4M
		316 stainless steel	Tantalum	Tantalum lining																		4T
		Hast. C lining	Hast. C	Hast. C lining																		4B
		Monel lining	Monel	Monel lining																		4L
		Tantalum lining	Tantalum	Tantalum lining																		4U
	500...50000 {5...500}	316 stainless steel	316L stainless steel	316 stainless steel																		5V
		SCS14	Hast. C	SUS316																		5W
		316 stainless steel	316L stainless steel	316 stainless steel																		5J
			+Au coating																			

Note 1 : (*1) For 50MPa {500bar} units, M12 is provided rather than M10.
 Note 2 : (*2) 100: 1 turn down is possible, but should be used at the span greater than 1/40 of the maximum span for better performance.

Digit	Description	Note	1	2	3	4	5	6	7	8	9	10	11	12	13	14	15	21	← Digit No. of code	
			F	K	G	0		5												
9	<Indicator and arrester>																			
	<u>Indicator</u>	<u>Arrester</u>																		
	None	None									A									
	Analog, 0 to 100% linear scale	None									B									
	Analog, custom scale	None									D									
	None	Yes									E									
	Analog, 0 to 100% linear scale	Yes									F									
	Analog, custom scale	Yes									H									
	Digital, 0 to 100% linear scale	None									L									
	Digital, custom scale	None									P									
	Digital, 0 to 100% linear scale	Yes									Q									
	Digital, custom scale	Yes									S									
	Digital, 0 to 100% linear scale (Local configurator unit with LCD display)	None									1									
	Digital, custom scale (Local configurator unit with LCD display)	None									2									
Digital, 0 to 100% linear scale (Local configurator unit with LCD display)	Yes									4										
Digital, custom scale (Local configurator unit with LCD display)	Yes									5										
10	<Approvals for hazardous locations>																			
	None (for ordinary locations)										A									
	TIIS, Flameproof (Conduit seal) (*6)	Note 6									B									
	TIIS, Flameproof (Cable gland seal) (*6)	Note 6									C									
	TIIS, Intrinsic safety										G									
	FM, Flameproof (or explosionproof) (*7)	Note 7									D									
	FM, Intrinsic safety and nonincensive										H									
	FM Combined of flameproof and intrinsic safety (*7)	Note 7									V									
	ATEX Flameproof (*8)	Note 8									X									
	ATEX Intrinsic safety										K									
	ATEX Type n										P									
	ATEX Combined of flameproof and intrinsic safety (*8)	Note 8									M									
	IECEX Scheme, Flameproof (*8)	Note 8									R									
	IECEX Scheme, Intrinsic safety										T									
	CSA, Flameproof (or explosionproof) (*9)	Note 9									E									
	CSA, Intrinsic safety and nonincensive										J									
NEPSI, Flameproof (or explosionproof) (*7)	Note 7									F										
NEPSI, Intrinsic safety (Entity)										S										
NEPSI, Combined of flameproof and intrinsic safety (*7)	Note 7									U										
11	<Vent/ drain and mounting bracket>																			
	Vent/drain Mounting bracket Process connection																			
	Standard None } Specify "A", "C" or "K"	Standard									A									
	Standard Yes, SUS304 } for the 7th	Standard									C									
	Standard Yes, SUS316 } digit code "B", "L", or "U"	Standard									K									
	Side None	Standard									D									
	Side Yes, SUS304	Standard									F									
Side Yes, SUS316	Standard									L										
12	<Options>																			
	Extra SS tag plate Stainless steel elec. housing Coating of cell																			
	None } None None None										Y									
	Yes } (*3)										B									
	None } None Yes	Note 3									M									
	Yes } None Yes	Note 5									N									
	None } Yes } (*5)	Note 5									P									
Yes } Yes } (*5)	Note 5									Q										
13	<Special applications and fill fluid>																			
	Treatment Fill fluid																			
	Standard Silicone oil																			
	Standard Fluorinated oil																			
	Degreasing Silicone oil																			
	Oxygen service Fluorinated oil (7th digit code "V", "W", "J" only)																			
	Chlorine service Fluorinated oil (7th digit code "H", "T", "B", "U")																			
NACE specification Silicone oil (Not available for 6th digit code "5", 7th digit code "T", "U", 15th digit code "A", "B")																				
Vacuum service Silicone oil for vacuum use																				
14	<Sensor O-ring / Gasket>																			
	Teflon (gasket)																			
15	<Bolt/nut> (*10)	Vent Drain plug type	Note 10																	
	Cr-Mo alloy hexagon socket head cap screw/carbon steel nut	Standard																		
	Cr-Mo alloy hexagon bolt/nut	Standard																		
	NACE bolt/nut (ASTM A193 B7M/A194 2HM)	Standard	Note 11																	
	NACE bolt/nut (ASTM A320 L7M/A194 2HM) } (*11)	Standard	Note 11																	
	304 stainless steel bolt/304 stainless steel nut	Standard	Note 11																	
	630 stainless steel bolt/304 stainless steel nut (*12)	Standard	Note 12																	
316 stainless steel bolt/316 stainless steel nut (*11)	Standard	Note 11																		
21	<Other options> (*4)		Note 4																	
	High accuracy type	Instruction manual attached																		
	Opposite Vent/Drain Plug Position	Instruction manual attached																		
	Instruction manual unattached																			
Opposite Vent/Drain Plug Position	Instruction manual unattached																			

Note3: (*3) Customer tag number can be engraved on standard stainless steel name plate. If extra tag plate is required, select "Yes".
 Note4: (*4) If other option is not necessary, 21st digit code is blank. In case of 21st digit code is blank, instruction manual attached.
 Note5: (*5) Not available for 10th digit code "B", "C".
 Note6: (*6) Available for 4th digit code "5", "S".

Note7: (*7) Not available for 4th digit code "8", "W".
 Note8: (*8) Available for 4th digit code "6", "8", "T", "W".
 Note9: (*9) Available for 4th digit code "6", "T".
 Note10: (*10) In case of tropical use, select stainless bolts and nuts.
 Note11: (*11) Not available for 6th digit code "5".
 Note12: (*12) Available for 6th digit code "5".

OUTLINE DIAGRAM (Unit:mm)

< CODE SYMBOLS : FKG

SW	T	X	V
----	---	---	---

 0

VM	J	T	HW
----	---	---	----

 5-□□□□□□-□□□□ >

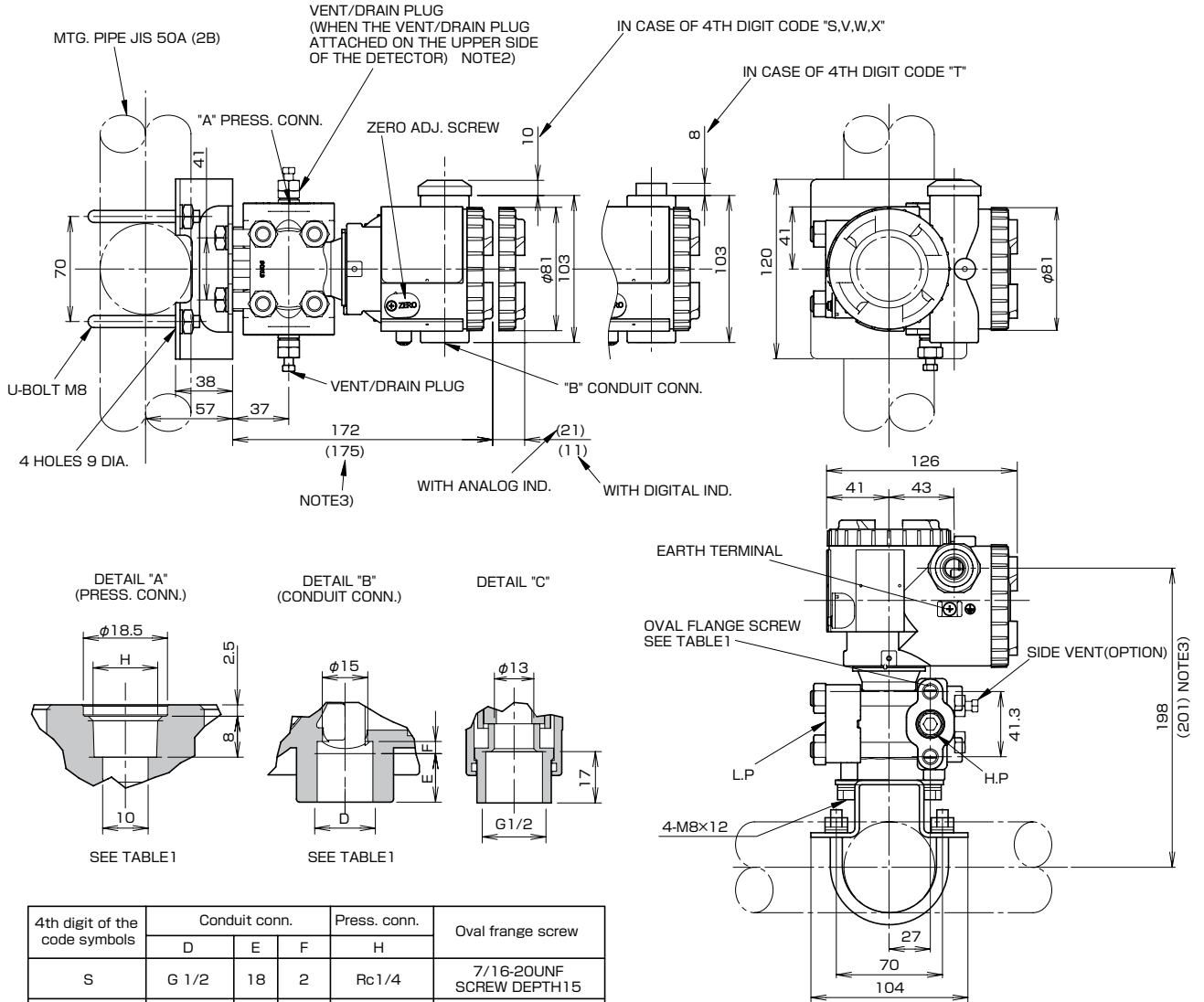

4th digit of the code symbols	Conduit conn.			Press. conn.	Oval frange screw
	D	E	F	H	
S	G 1/2	18	2	Rc1/4	7/16-20UNF SCREW DEPTH15
T	1/2-14NPT	16	4	1/4-18NPT	7/16-20UNF SCREW DEPTH15
V	Pg13.5	10.5	4.5	1/4-18NPT	M10 SCREW DEPTH15
W	M20x1.5	16	4	1/4-18NPT	M10 SCREW DEPTH15
X	Pg13.5	10.5	4.5	1/4-18NPT	7/16-20UNF SCREW DEPTH15

TABLE 1

CONNECTION DIAGRAM

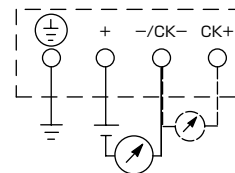

OPTION PARTS FOR FLAMEPROOF OF TIIS (JAPAN)

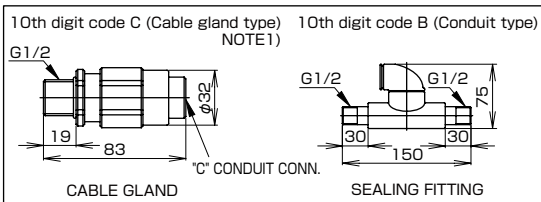

NOTE1) IN CASE OF 10TH CODE "C", φ11 CABLE IS SUITBLE.
 NOTE2) THE PRESSURE CONNECTOR IS LOCATED ON THE DOWN SIDE SURFACE OF THE DETECTOR, WHEN THE VENT/DRAIN PLUG IS ATTACHED ON THE UPPER SIDE OF THE DETECTOR (WHEN THE 21ST DIGIT OF THE CODE SYMBOLS : C, P).
 NOTE3) WHEN THE 7TH DIGIT OF THE CODE SYMBOLS "C,H,M,T"

< CODE SYMBOLS : FKG

S	W
T	X
V	

 0

B
L
U

 5-□□□□□□-□□□□ >

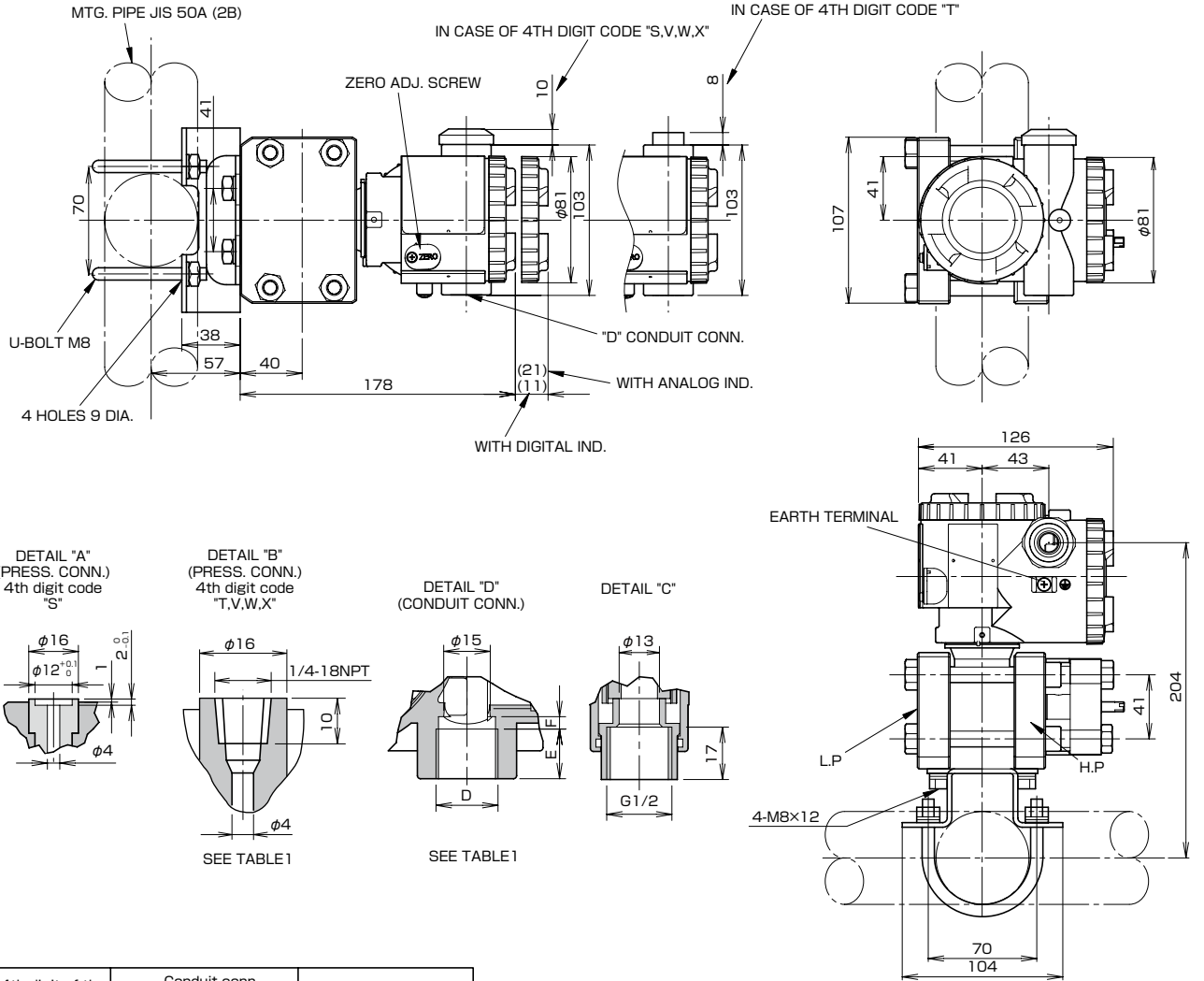

4th digit of the code symbols	Conduit conn.			Oval flange screw
	D	E	F	
S	G 1/2	18	2	7/16-20UNF SCREW DEPTH 15
T	1/2-14NPT	16	4	7/16-20UNF SCREW DEPTH 15
V	Pg13.5	10.5	4.5	M10 SCREW DEPTH 15
W	M20x1.5	16	4	M10 SCREW DEPTH 15
X	Pg13.5	10.5	4.5	7/16-20UNF SCREW DEPTH 15

TABLE 1

CONNECTION DIAGRAM

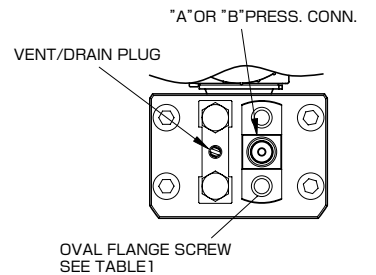
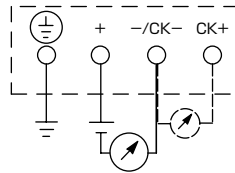

OPTION PARTS FOR FLAMEPROOF OF TIIS (JAPAN)

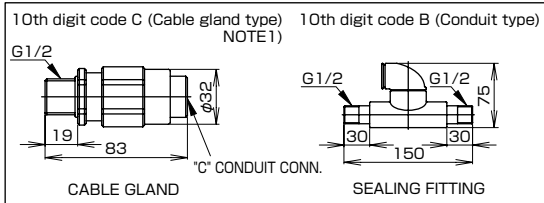

NOTE1) IN CASE OF 10TH CODE "C", φ11 CABLE IS SUITBLE.

< CODE SYMBOLS : FKG

5	8
6	9
7	

 0

B
L
U

 5-□□□□□□-□□□□ >

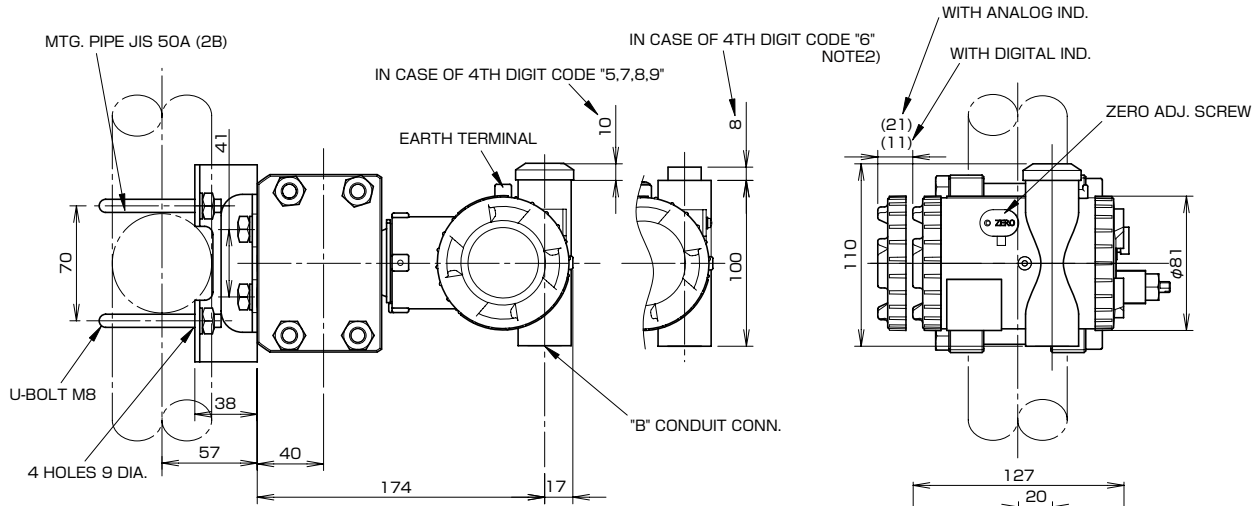

DETAIL "A"
(PRESS. CONN.)
4th digit code
"5"

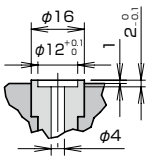

DETAIL "B"
(PRESS. CONN.)
4th digit code
"6,7,8,9"

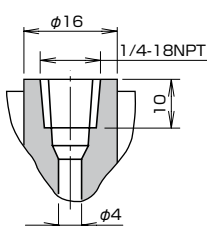

SEE TABLE 1

DETAIL "D"
(CONDUIT CONN.)

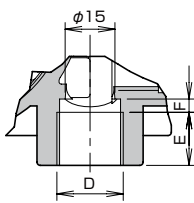

SEE TABLE 1

DETAIL "C"

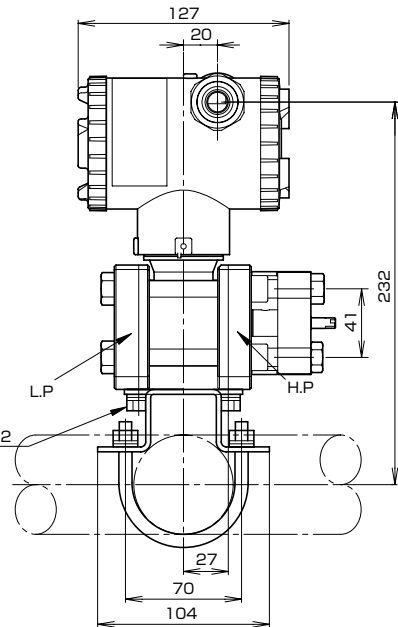
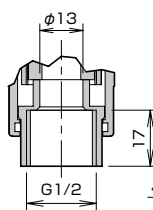

4th digit of the code symbols	Conduit conn.			Oval frange screw
	D	E	F	
5	G 1/2	18	2	7/16-20UNF SCREW DEPTH15
6	1/2-14NPT	16	4	7/16-20UNF SCREW DEPTH15
7	Pg13.5	10.5	4.5	M10 SCREW DEPTH15
8	M20x1.5	16	4	M10 SCREW DEPTH15
9	Pg13.5	10.5	4.5	7/16-20UNF SCREW DEPTH15

TABLE 1

CONNECTION DIAGRAM

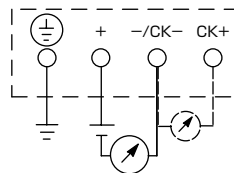

"A" OR "B" PRESS. CONN.

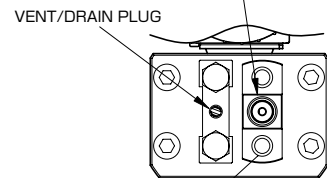

OPTION PARTS FOR FLAMEPROOF OF TIIS (JAPAN)

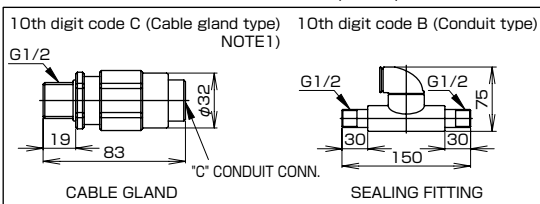

NOTE1) IN CASE OF 10TH CODE "C", φ11 CABLE IS SUITBLE.

TABLE 2

Authorities	Intrinsic safety																					
ATEX	<p>Ex II 1 G Ex ia IIC T5 Tamb = -40°C to +50°C Ex ia IIC T4 Tamb = -40°C to +70°C</p> <p>Entity Parameters: Ui=28V, Ii=94.3mA, Pi=0.66W, Ci=26nF (Without Arrester), Li=0.6mH (Without analog indicator), Ci=36nF (With Arrester), Li=0.7mH (With analog indicator)</p>																					
Factory Mutual (pending)	<p>Class I II III Div.1 Groups A, B, C, D, E, F, G T4 Entity Type 4X</p> <table border="1"> <thead> <tr> <th colspan="2">Model code</th> <th>Tamb</th> </tr> <tr> <th>9th digit</th> <th>13th digit</th> <th></th> </tr> </thead> <tbody> <tr> <td>A,B,D</td> <td>Y,G,N,R</td> <td>-40°C to +85°C</td> </tr> <tr> <td>L,P,1,2</td> <td>Y,G,N,R</td> <td>-20°C to +80°C</td> </tr> <tr> <td>Q,S,4,5</td> <td>Y,G,N,R</td> <td>-20°C to +60°C</td> </tr> <tr> <td>E,F,H</td> <td>Y,G,N,R</td> <td>-40°C to +60°C</td> </tr> <tr> <td>-</td> <td>W,A,D</td> <td>-10°C to +60°C</td> </tr> </tbody> </table> <p>Entity Parameters: Vmax=42.4V, Imax=113mA, Pi=1W, Ci=35.98nF, Li=0.694mH</p>	Model code		Tamb	9th digit	13th digit		A,B,D	Y,G,N,R	-40°C to +85°C	L,P,1,2	Y,G,N,R	-20°C to +80°C	Q,S,4,5	Y,G,N,R	-20°C to +60°C	E,F,H	Y,G,N,R	-40°C to +60°C	-	W,A,D	-10°C to +60°C
Model code		Tamb																				
9th digit	13th digit																					
A,B,D	Y,G,N,R	-40°C to +85°C																				
L,P,1,2	Y,G,N,R	-20°C to +80°C																				
Q,S,4,5	Y,G,N,R	-20°C to +60°C																				
E,F,H	Y,G,N,R	-40°C to +60°C																				
-	W,A,D	-10°C to +60°C																				
CSA	<p>Class I Div.1 Groups A, B, C, D Class II Div.1 Groups E, F, G Class III Div.1</p> <p>Temp Code T5 Tamb max = +50°C Temp Code T4 Tamb max = +70°C</p> <p>Entity Parameters: Vmax=28V, Imax=94.3mA, Ci=25nF (Without Arrester), Ci=36nF (With Arrester), Li=0.6mH (Without analog meter), Li=0.7mH (With analog meter)</p>																					
TIIS	<p>Ex ia IIC T4 Tamb max = +60°C</p> <p>Entity Parameters: Ui=28V, Ii=94.3mA, Pi=0.66W, Ci=38.4nF, Li=0.694mH</p>																					
IECEX Scheme	<p>Ex ia IIC T4 Tamb = -40°C to +70°C Ex ia IIC T5 Tamb = -40°C to +50°C</p> <p>Entity Parameters: Ui=28V, Ii=94.3mA, Pi=0.66W, Ci=26nF (Without Arrester), Li=0.6mH (Without analog indicator), Ci=36nF (With Arrester), Li=0.7mH (With analog indicator)</p>																					
NEPSI	<p>Ex ia IIC T4 Ex d IIB+H₂ T6 / Ex ia IIC T4</p> <table border="1"> <thead> <tr> <th colspan="2">Model code</th> <th>Tamb</th> </tr> <tr> <th>9th digit</th> <th>13th digit</th> <th></th> </tr> </thead> <tbody> <tr> <td>A,B,D</td> <td>Y,G,N,R</td> <td>-40°C to +85°C</td> </tr> <tr> <td>L,P,1,2</td> <td>Y,G,N,R</td> <td>-20°C to +80°C</td> </tr> <tr> <td>Q,S,4,5</td> <td>Y,G,N,R</td> <td>-20°C to +60°C</td> </tr> <tr> <td>E,F,H</td> <td>Y,G,N,R</td> <td>-40°C to +60°C</td> </tr> <tr> <td>-</td> <td>W,A,D</td> <td>-10°C to +60°C</td> </tr> </tbody> </table> <p>Entity Parameters: Ui=42.4V, Ii=113mA, Pi=1W, Ci=35.98nF, Li=0.694mH</p>	Model code		Tamb	9th digit	13th digit		A,B,D	Y,G,N,R	-40°C to +85°C	L,P,1,2	Y,G,N,R	-20°C to +80°C	Q,S,4,5	Y,G,N,R	-20°C to +60°C	E,F,H	Y,G,N,R	-40°C to +60°C	-	W,A,D	-10°C to +60°C
Model code		Tamb																				
9th digit	13th digit																					
A,B,D	Y,G,N,R	-40°C to +85°C																				
L,P,1,2	Y,G,N,R	-20°C to +80°C																				
Q,S,4,5	Y,G,N,R	-20°C to +60°C																				
E,F,H	Y,G,N,R	-40°C to +60°C																				
-	W,A,D	-10°C to +60°C																				

Authorities	Flameproof																					
ATEX	<p>Ex II 2 GD Ex d IIC T6 IP66/67 T85°C Tamb = -40°C to +65°C Ex d IIC T5 IP66/67 T100°C Tamb = -40°C to +85°C</p>																					
Factory Mutual	<p>Class I Div.1 Groups B, C, D T6 Type 4X Class II III Div.1 Groups E, F, G T6 Type 4X Tamb max = +60°C</p>																					
CSA	<p>Class I Div.1 Groups C, D Class II Div.1 Groups E, F, G Class III Div.1</p> <p>Note) "Seal Not Required" enclosure is allowed.</p>																					
TIIS	<p>Ex do IIB+H₂ T4 Tamb max = +60°C Maximum process temp. = +120°C</p>																					
IECEX Scheme	<p>Ex d IIC T5 IP66/67 Tamb = -40°C to +85°C Ex d IIC T6 IP66/67 Tamb = -40°C to +65°C</p>																					
NEPSI	<p>Ex d IIB+H₂ T6 Tamb = -40°C to +60°C</p>																					
Authorities	Type n Nonincendive																					
ATEX	<p>Ex II 3 GD EEx nL IIC T5 Tamb = -40°C to +50°C EEx nL IIC T4 Tamb = -40°C to +70°C</p> <p>Specific Parameters: Model without arrester: Ui=42.4V, Ii=113mA, Pi=1W, Ci=25.18nF, Li=0.694mH Model with arrester: Ui=32V, Ii=113mA, Pi=1W, Ci=35.98nF, Li=0.694mH</p> <p>EEx nAL IIC T5 Tamb = -40°C to +50°C EEx nAL IIC T4 Tamb = -40°C to +70°C</p> <p>Specific Parameters: Model without arrester: Umax=42.4V, Imax=113mA, Pmax=1W Model with arrester: Umax=32V, Imax=113mA, Pmax=1W</p>																					
Factory Mutual (pending)	<p>Class I II III Div.2 Groups A, B, C, D, F, G T4 Entity Type 4X</p> <table border="1"> <thead> <tr> <th colspan="2">Model code</th> <th>Tamb</th> </tr> <tr> <th>9th digit</th> <th>13th digit</th> <th></th> </tr> </thead> <tbody> <tr> <td>A,B,D</td> <td>Y,G,N,R</td> <td>-40°C to +85°C</td> </tr> <tr> <td>L,P,1,2</td> <td>Y,G,N,R</td> <td>-20°C to +80°C</td> </tr> <tr> <td>Q,S,4,5</td> <td>Y,G,N,R</td> <td>-20°C to +60°C</td> </tr> <tr> <td>E,F,H</td> <td>Y,G,N,R</td> <td>-40°C to +60°C</td> </tr> <tr> <td>-</td> <td>W,A,D</td> <td>-10°C to +60°C</td> </tr> </tbody> </table>	Model code		Tamb	9th digit	13th digit		A,B,D	Y,G,N,R	-40°C to +85°C	L,P,1,2	Y,G,N,R	-20°C to +80°C	Q,S,4,5	Y,G,N,R	-20°C to +60°C	E,F,H	Y,G,N,R	-40°C to +60°C	-	W,A,D	-10°C to +60°C
Model code		Tamb																				
9th digit	13th digit																					
A,B,D	Y,G,N,R	-40°C to +85°C																				
L,P,1,2	Y,G,N,R	-20°C to +80°C																				
Q,S,4,5	Y,G,N,R	-20°C to +60°C																				
E,F,H	Y,G,N,R	-40°C to +60°C																				
-	W,A,D	-10°C to +60°C																				
CSA	<p>Class I Div.2 Groups A, B, C, D Class II Div.2 Groups E, F, G Class III Div.2</p> <p>Temp Code T5 Tamb max = +50°C Temp Code T4 Tamb max = +70°C</p> <p>Entity Parameters: Vmax=28V, Ci=25.18nF (Without Arrester), Ci=35.98nF (With Arrester), Li=0.694mH</p>																					

⚠ Caution on Safety

*Before using this product, be sure to read its instruction manual in advance.

Fuji Electric Systems Co., Ltd.

International Sales Div.1

Sales Group

Gate City Ohsaki, East Tower, 11-2, Osaki 1-chome,
Shinagawa-ku, Tokyo 141-0032, Japan

<http://www.fesys.co.jp/eng>

Phone: 81-3-5435-7280, 7281 Fax: 81-3-5435-7425

<http://www.fic-net.jp/eng>