

PUM Series

Multi-loop module type Temperature controller

Smart!

- Optimum multiple-zone control
- PLC function (by plug-in module)
- Program-less host communication

User friendly!

- Detachable terminal
- Simple loader operation

Fast!

- High-speed data communication (230.4kbps)
- High-speed data sampling



Fuji Electric Systems Co., Ltd.

FEATURES

Smart!

Heater break alarm CT (8 points)

A break in a three-phase heater can be detected with using 2 points CT per 1-channel.

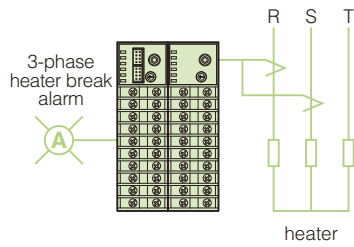

Optimum multi-zone control

Our original algorithm maintains stable and highly precise temperature control in multiple zones where interference is unavoidable.

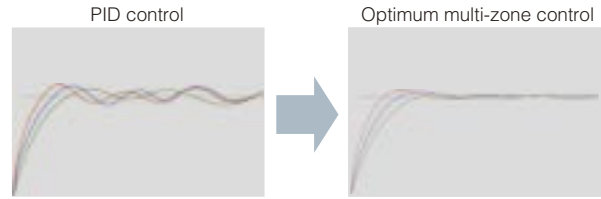

Integration of PLC function <Now developing>

Digital I/O signal processing up to 16-k steps and 300 points is allowed.

PLC operation control Module

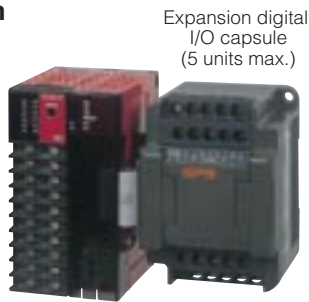

High-speed communication with upper device

High-speed communication is possible because it is only assigned important data.

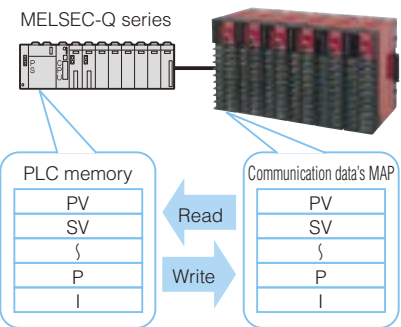

User friendly!

Detachable terminal structure

The terminal is attachable and detachable without using a screw driver. Wiring time for maintenance is reduced substantially.

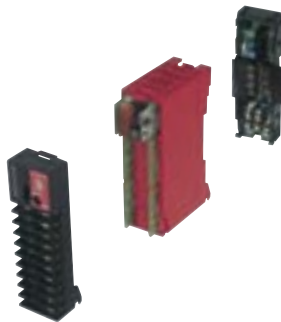

Simple loader on the Personal Computer

Simple loader is available to change all module parameter setting without changing each loader connection.

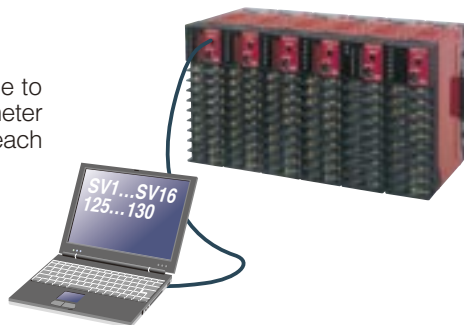

Easy to attach to the DIN rail

It is easy to attached the DIN rail by backside lock-tab. The backside lock-tab can connect each multi-loop controller.

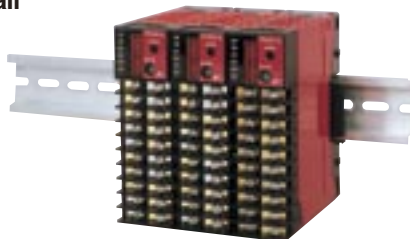

Fast!

High-speed communication with upper device

You can rest easy with the multi-loop controller because hi-speed communication with 230.4kbps and no time-lag.

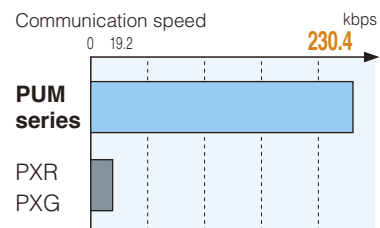

High-speed sampling time

200msec sampling time enable it to apply to not only temperature measurement but also process measurement such as pressure control and flow control, etc.

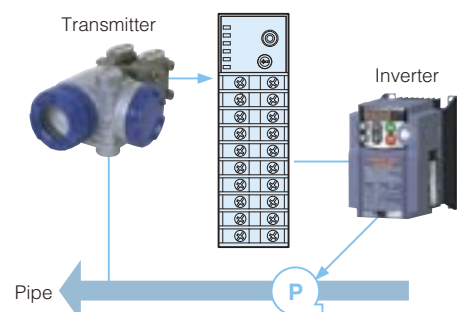

APPLICATIONS

Case 1 Input/output device of I/O units in programmable logic controller

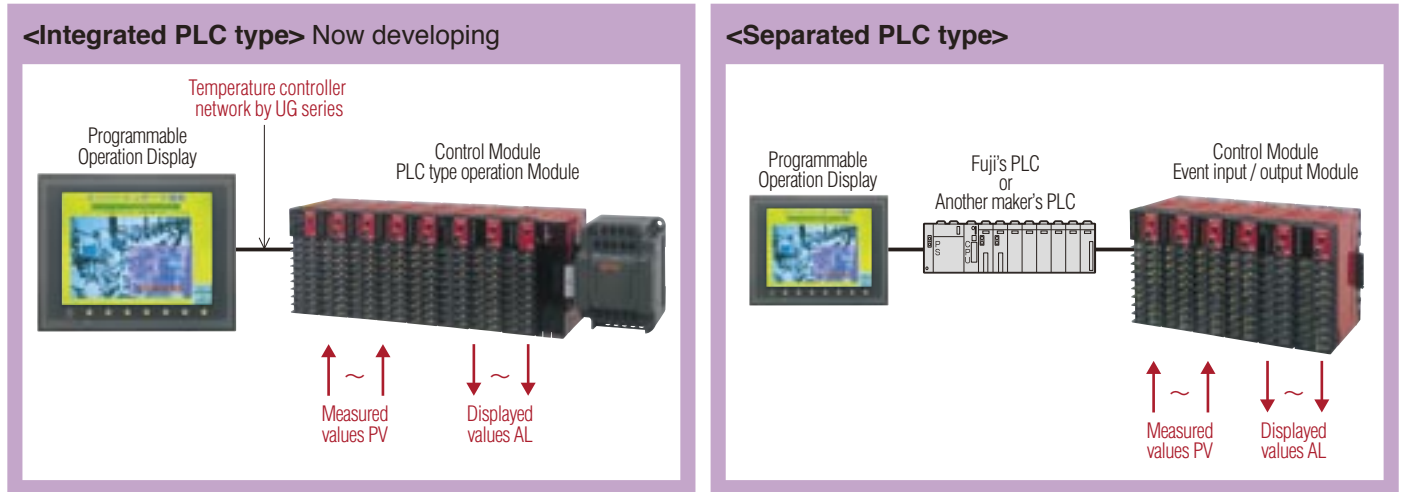

Case 2 Temperature controller

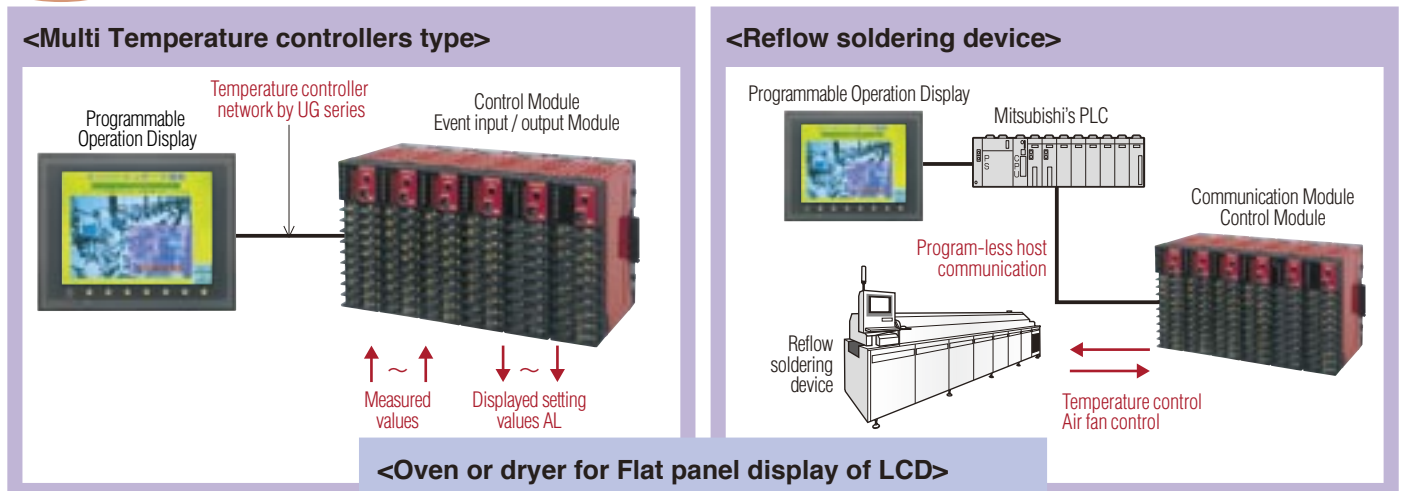

<Oven or dryer for Flat panel display of LCD>

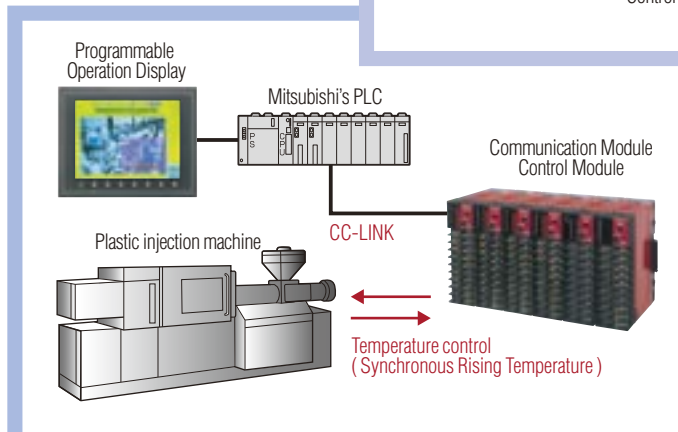
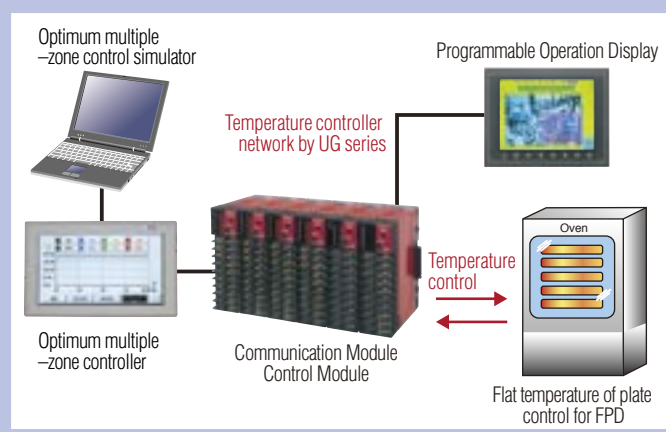



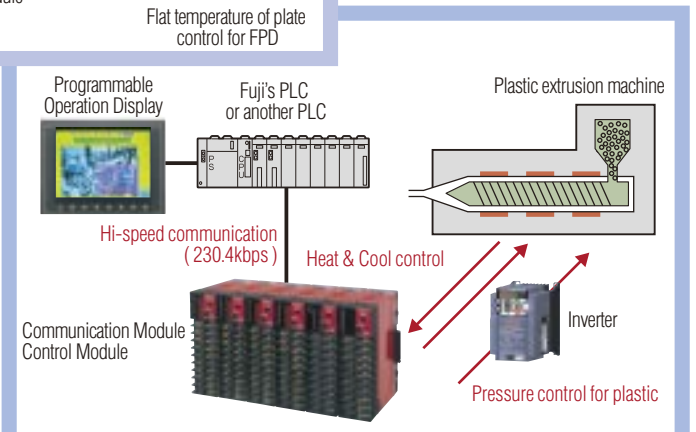











<Plastic injection machine>

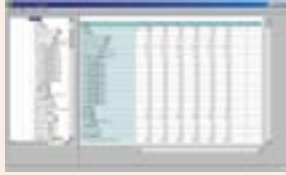

<Plastic extrusion machine>

VARIATIONS

	Kind	Type	See page	
Temperature control	Control Module	PUMA/B	12	
	Features Inputs have 2ch or 4ch type 3-phase Heater break detections have each ch. (option)			
Digital Input/output	Event input/output Module	PUME	15	
	Features 8 points alarm DO output 8 points DI input for external switching control			
Analog Input/output <Now developing>	Analog input & output Module	PUMV	16	
	Features Inputs have 4 points and Outputs have 4 points			
	Analog input Module	PUMN		18
	Features Inputs have 4 points			
Analog output Module	PUMT	20		
Features Outputs have 4 points				
Communication	Hi-speed RS-485 Communication Module <Now developing>	PUMCR	21	
	Features Communication speed data with 230.4kbps Hi-speed original communica- tion, Now developing			
	CC-LINK Communication Module	PUMCL		22
Features Communication speed data with 10Mbps				
	Mitsubishi PLC's Module with programless communications <Now developing>	PUMCM	23	
	Features Direct address map only for Mitsubishi's PLC.Reduction of your programming work for Mitsubishi's PLC.			

	Kind	Type	See page
PLC <Now developing>	PLC operation control Module <Now developing>	PUMP	none
	Features 16k step programming		
Support Tools	Expansion digital I/O capsule	SPB Series	none
	Features Up to 300 points DIO can be expanded.		
Original Controller <Now developing>	Programming Loader on Personal computer		10
	Features Easy setting and user friendly		
Peripheral instrument	Optimum multiple-zone controller		33
	Features Optimum multi-zone control by Fuji's original algorithm		
Accessory	Programmable Operation Display		34
	Features Easy connect by temperature control network		
Accessory	Thyristor Units		11
	Features High performance power control units		
Accessory	Automation Software		11
	Features SCADA software, example		
Accessory	<ul style="list-style-type: none"> Terminating resistance for RS-485 DIN rail end plate Connector's cover side-by-side Terminal cover of front 	<ul style="list-style-type: none"> Programming Loader for PLC operation control module <Now developing> Connection cable for PUM series Fuji's original CT input cable Fuji's original CT 	31

SELECTION FLOW for SYSTEM CONSTRUCTION

How to select the SYSTEM for your needs, below 1 to 5.

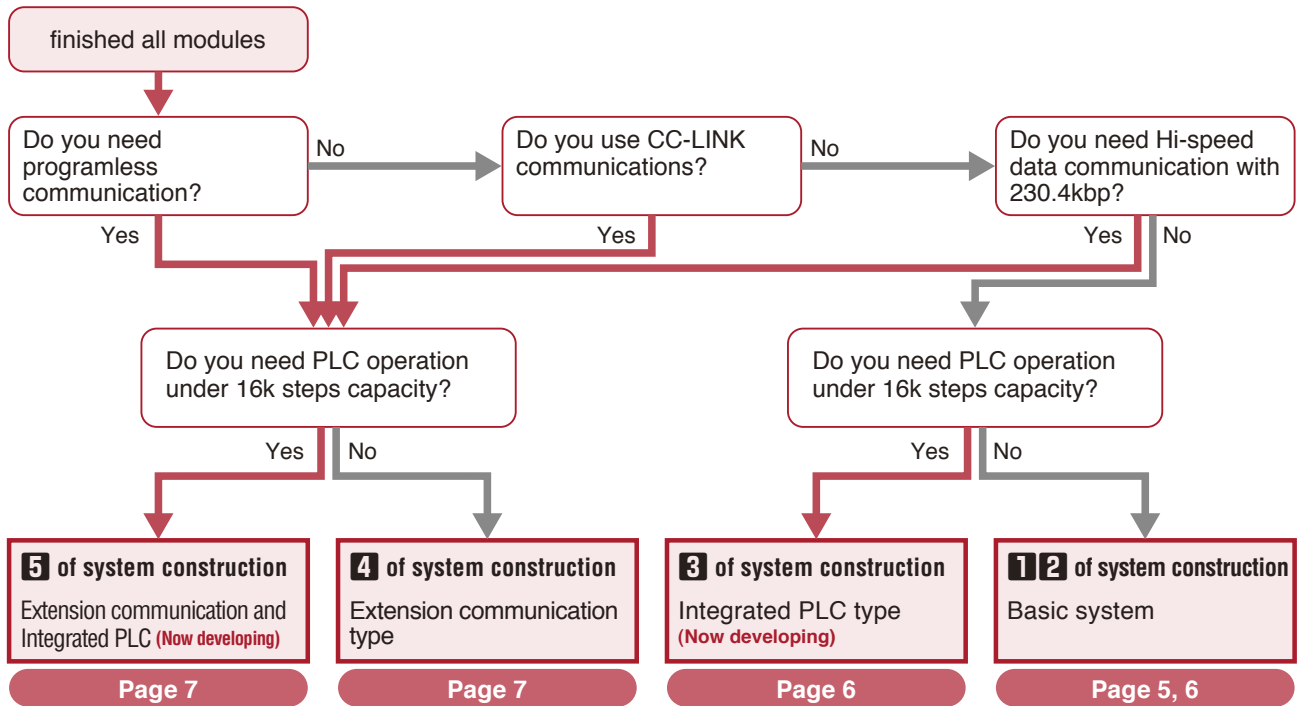

SYSTEM CONSTRUCTION FOR EXAMPLE

1 Basic system (minimum system construction)

- In case of minimum system construction, 4ch or 2ch
- RS-485 communication is standard, not option
- *Use PUMB for heating and cooling control

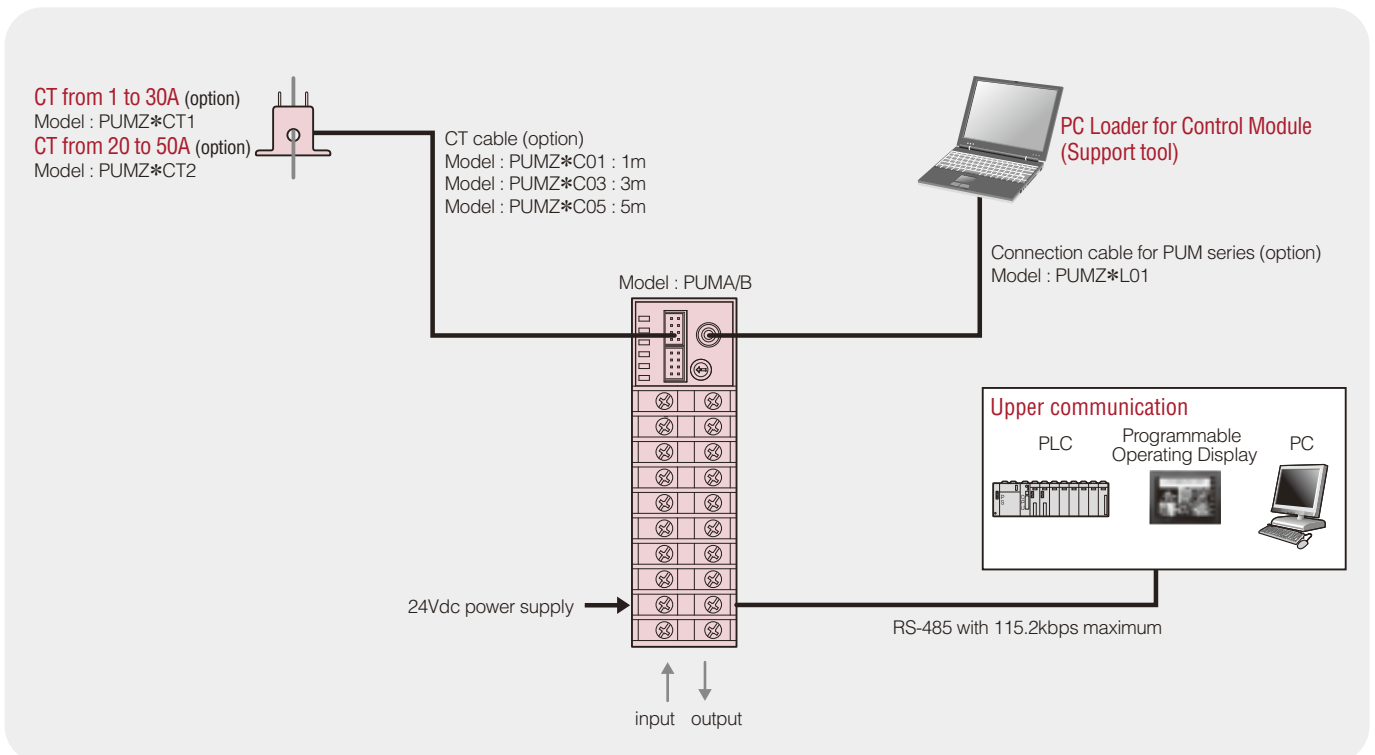

2 Basic system (maximum system construction)

- When you use analog input/output, or digital input/output in addition to 4ch/2ch Module.
- You can construct up to 16 units for control, and analog input/output type (control module, analog input/output) plus up to 16 units for digital input/output type (event module).
- Setting St. numbers is necessary for internal communications.

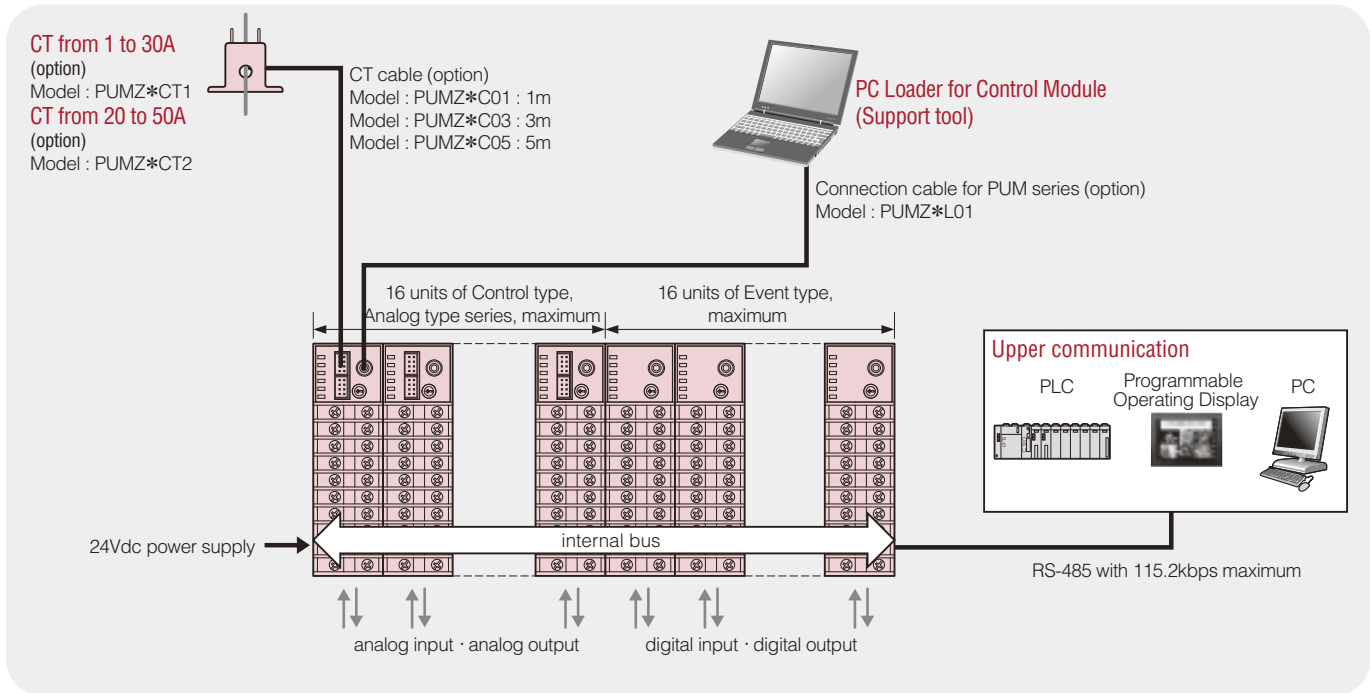

3 Integrated PLC type (Now developing)

- In the case of PLC function system construction
- Up to 300 points I/O is possible with using an expansion units.

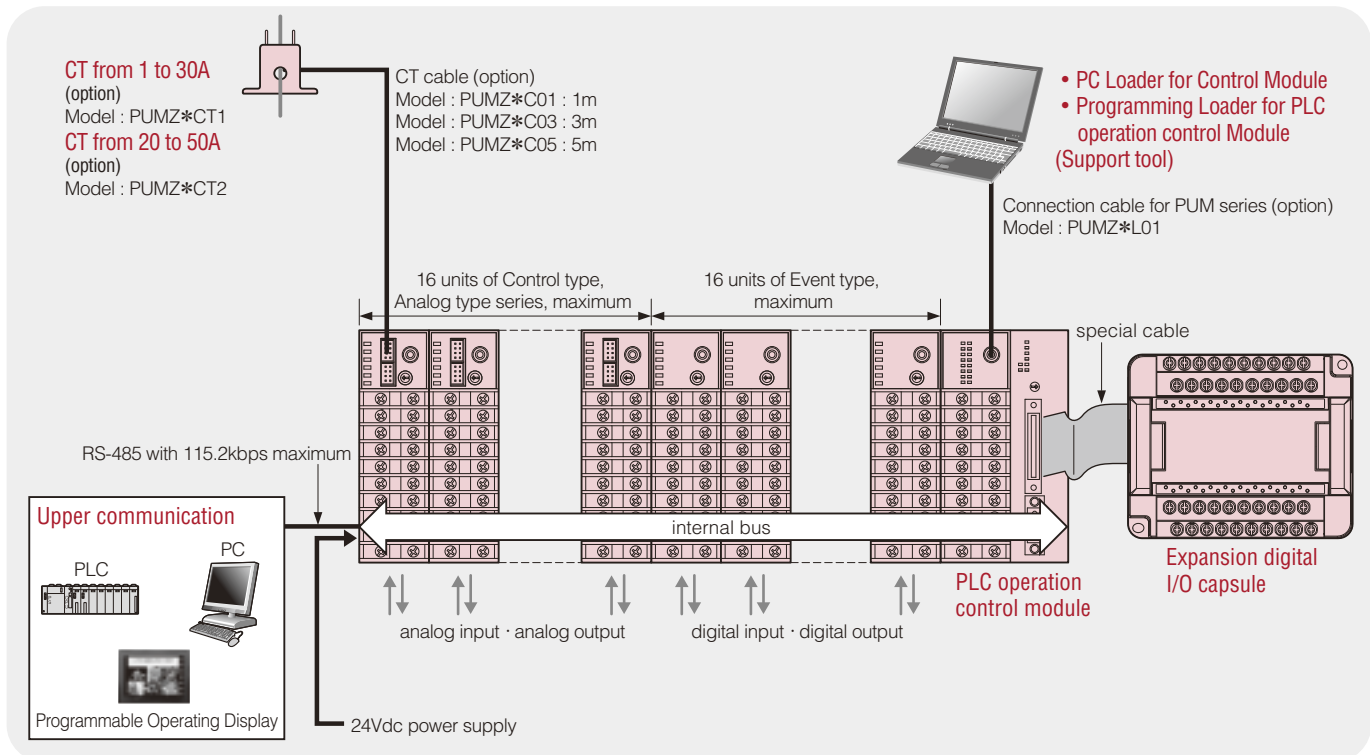

4 Enhanced communication type (Now developing except for CC-LINK communication type)

- Performing high-speed communication (230.4kbps), CC-LINK communication, and PLC program-less communication.

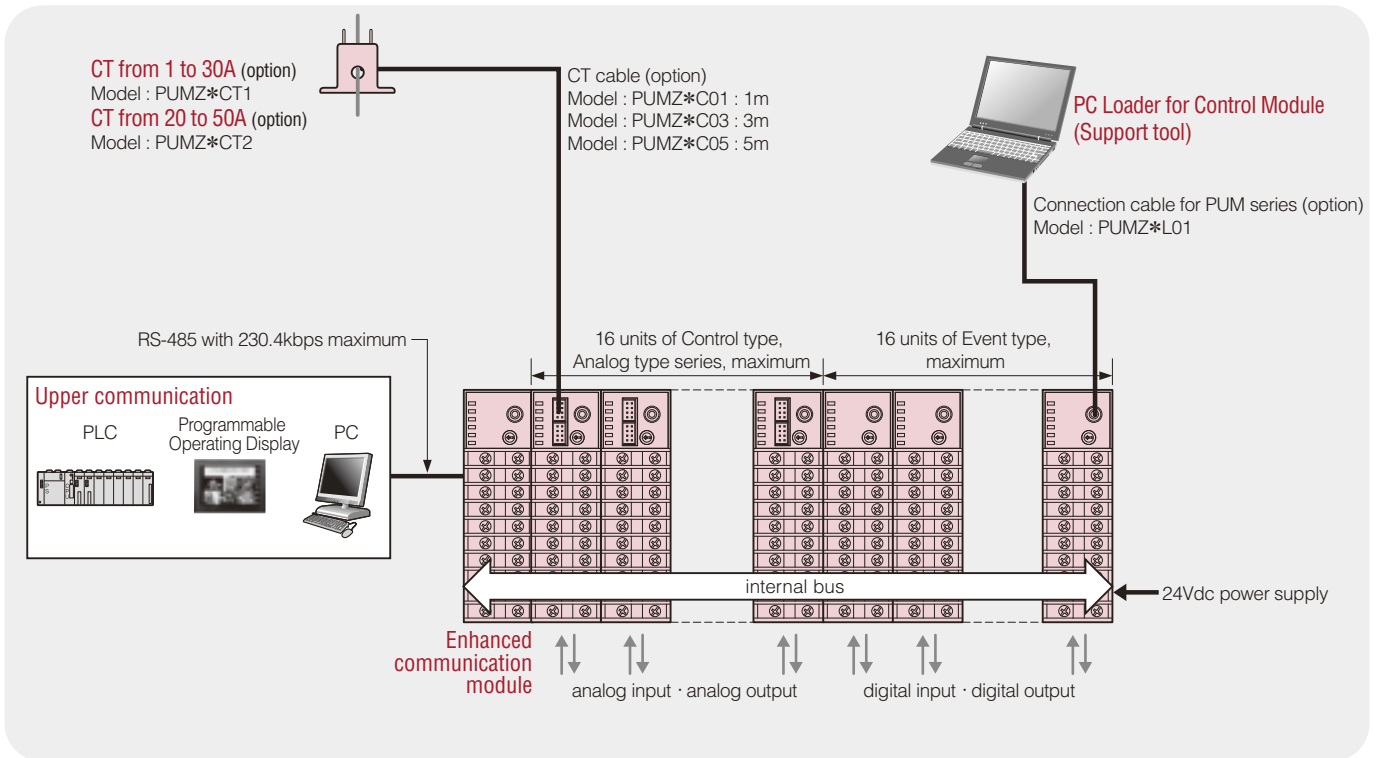

5 Enhanced communication and Integrated PLC (Now developing)

- In case of PLC functions system construction with enhanced communication module.

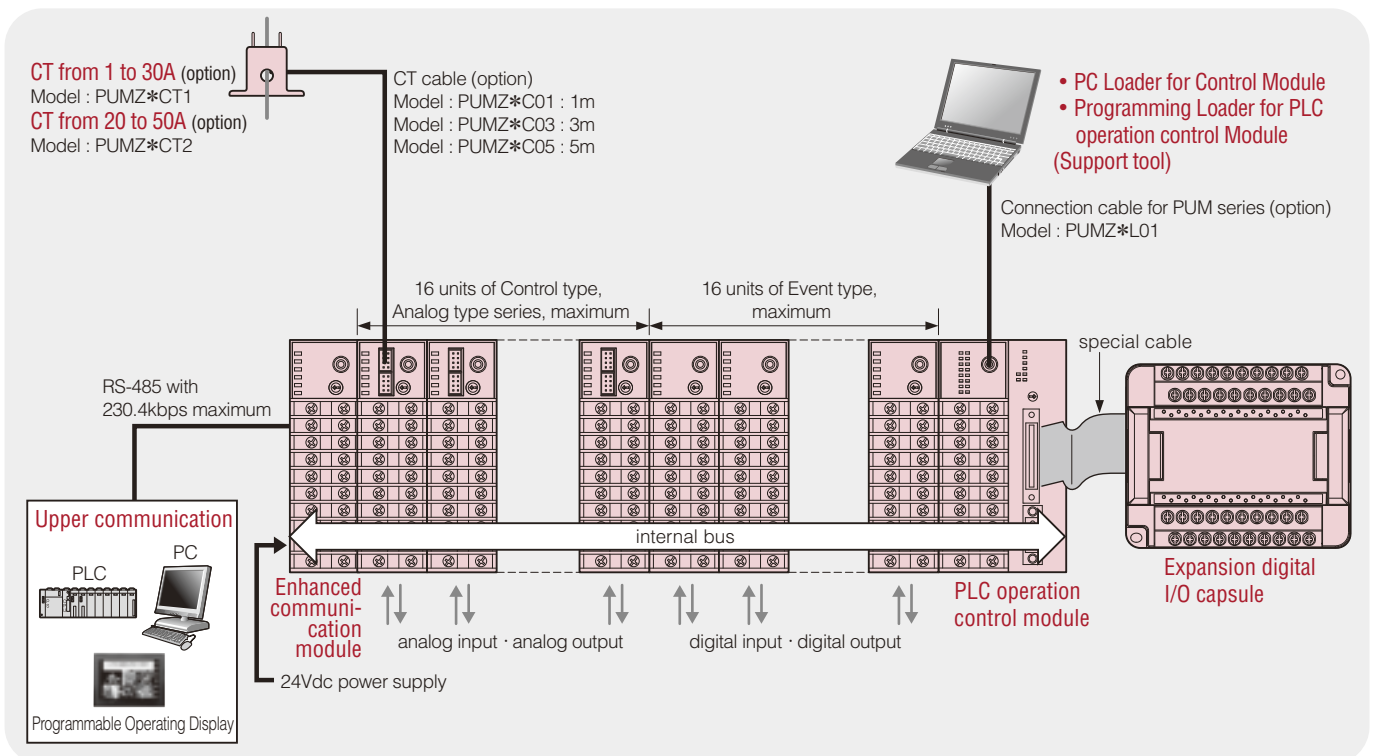

COMMUNICATION MODULE

1-1 Modbus protocol Communications (lateral connections of a maximum of 16 modules)

Control Module, Analog I/O Module are 16 units maximum and Event I/O Module are 16 units maximum.

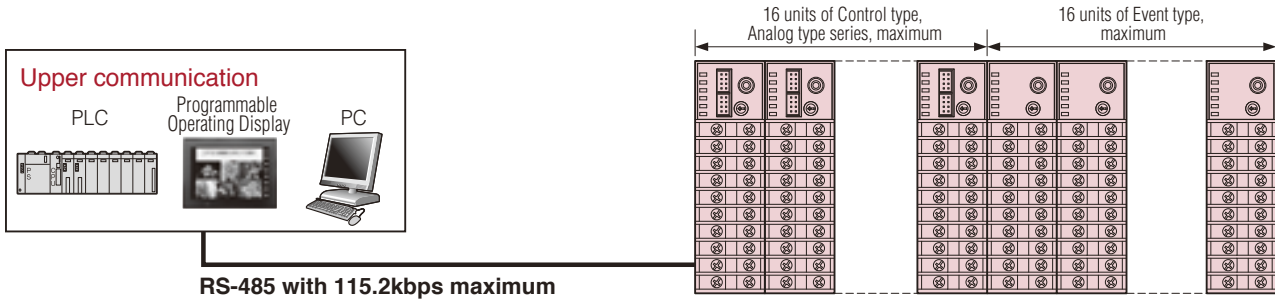

1-2 Modbus protocol Communications (distributed allocations)

Control Module, Analog I/O Module are 16 units maximum and Event I/O Module are 16 units maximum.

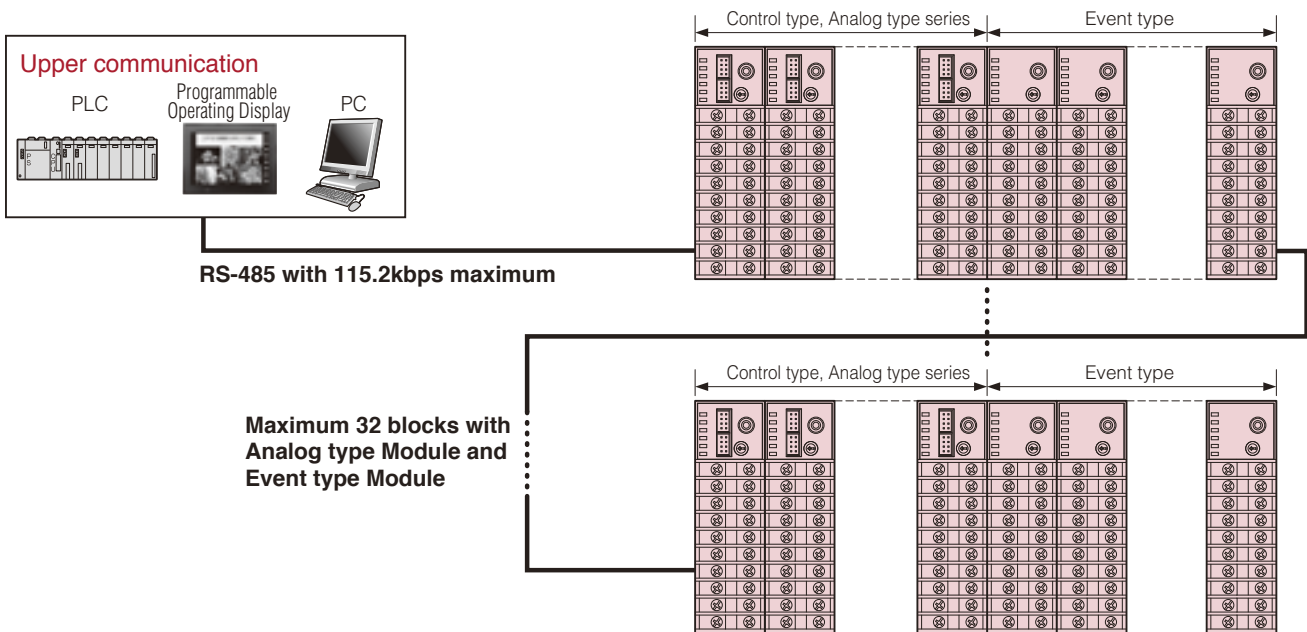

2-1 Hi-speed RS-485 Communications by Modbus protocol (Extension communication module)

Analog I/O Module or Control Module are 1024 points.

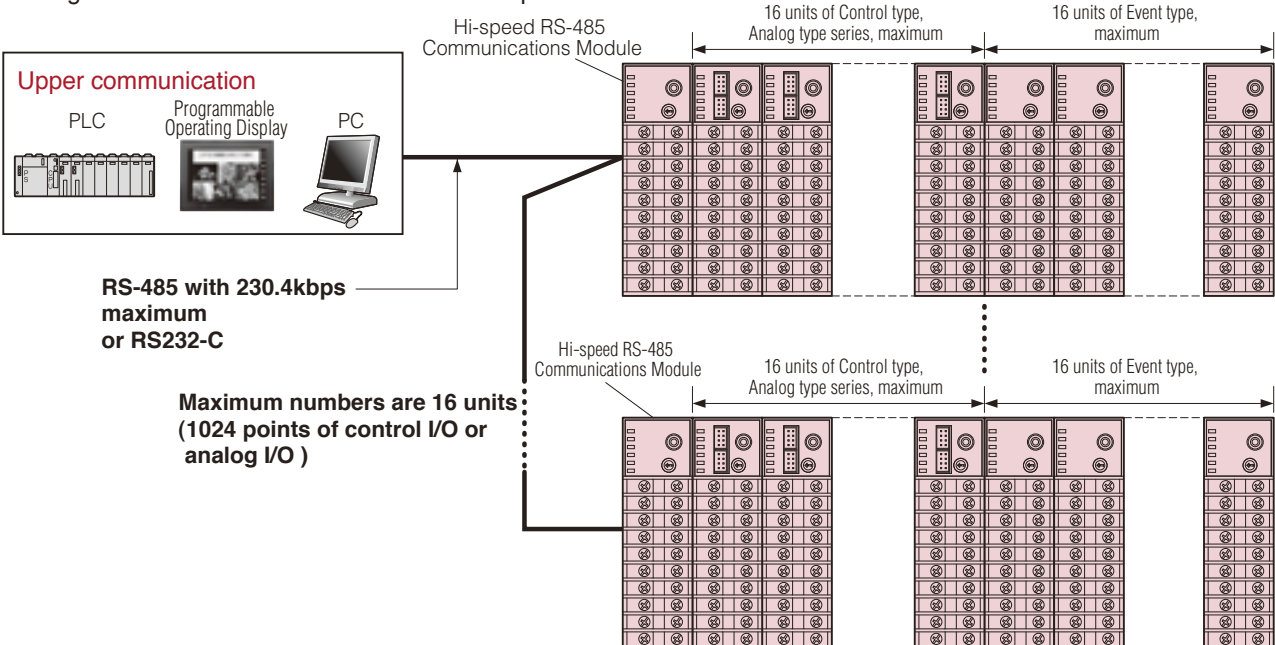

3-1 CC-Link protocol Communications (continuance connections by maximum)

Control Module, Analog I/O Module are 16 units maximum and Event I/O Module are 16 units maximum.

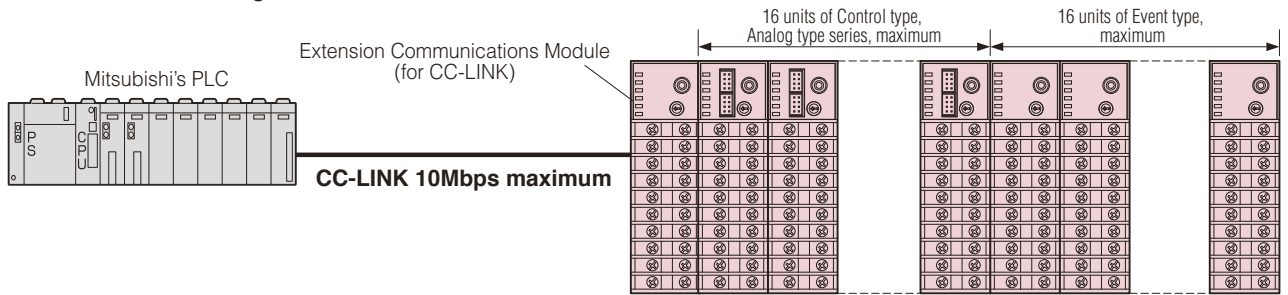

3-2 CC-Link protocol Communications (distributed allocations)

Control Module, Analog I/O Module are 64 units maximum

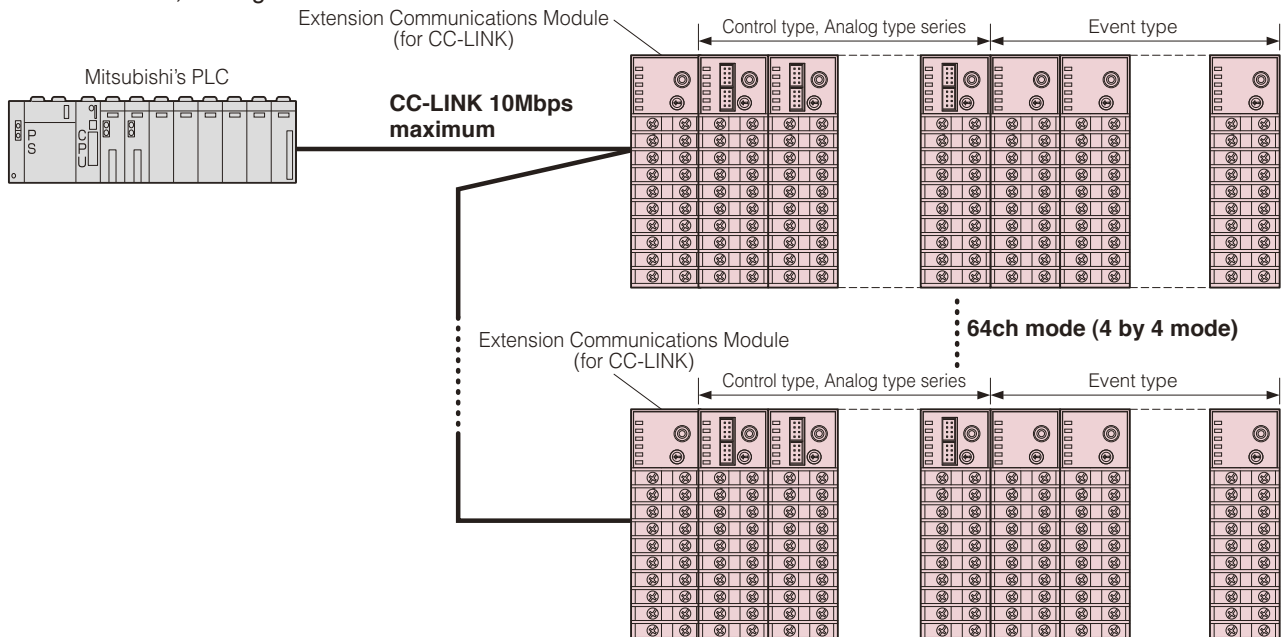

4-1 Mitsubishi's PLC with programless communications *Now developing

Control Module, Analog I/O Module are 16 units maximum and Event I/O Module are 16 units maximum.

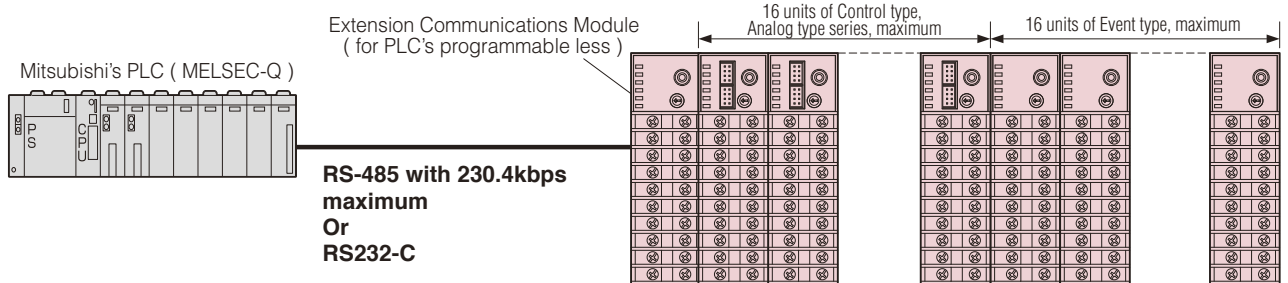

○ LOADER SOFTWARE

PUM series are prepared by 2-type loader software. One is each Module, and another one is only PLC operation control module. This software is supported by windows PC.

Basic Loader for Control Module, Analog I/O Module, and Event I/O Module

It is available to download for FUJI's HP. This URL is <http://www.fic-net.jp>

SMART LOADER

You can set the all modules with the loader ports on the control modules without replacing cables. You can grasp the whole control conditions easily by monitoring parameter display, setting, and control conditions.

EASY LOADER

You can operate this software without having the instruction manual!

This software has PULL DOWN MENU, and detailed online help.

Editing display is tree style, and it is easy to search your parameter needs.

BILINGUAL LOADER

English version and Japanese version be selected initial configurations.

PARTNER SETTINGS and NAMES OPTIMIZE TO MEET CUSTOMER'S REQUIREMENT

If you can use "favorite function" on software, it is easy to access time important parameters. It can charge the name of each parameters at any time.

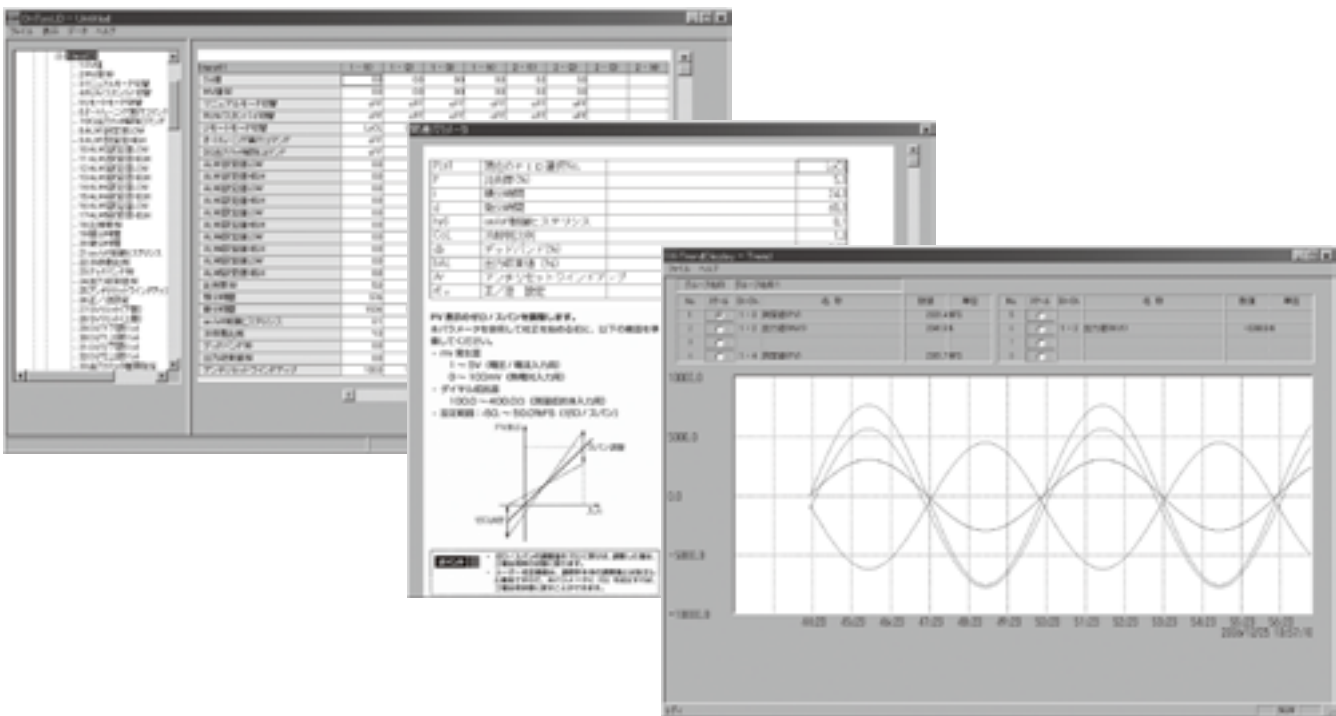

Basic function	Setting, displaying, editing the parameters Display the construction of all modules DATA trending Utility function (copy the same parameters, printing and saving data by CSV files) Communications (Upload, Download)	Handling model	CONTROL MODULE : MODEL PUMA/PUMB ANALOG I/O MODULE : MODEL PUMV/PUMN/PUMT EVENT I/O MODULE : MODEL PUME
Connection	Only original connection cable, but it is same as PXH or PXG cable. Original cable : MODEL PUMZ*L01, Pin-jack 3-pole, D-sub 9pin	Recommended environment of personal computer	OS:WINDOWS 2000, WINDOWS XP (Global version and Japanese local version) CPU: 300MHz MEMORY: 128MB over FREE SPACE in Hard Disk: over 500MB CD-ROM drive : necessary MONITOR: over 1024 × 768

○ THYRISTOR UNITS

Feature

- 1 All units are EC compliance. UL approval is available.
- 2 Outline shape is compact. You can use control panel space with minimum size.
- 3 Low electrical switching noise for using the burst firing control mode other control mode.
- 4 The front cover is same as terminal cover.
- 5 Digital control device because this thyristor units have micro-processor inside.
- 6 Light-weight plastic cover and molding structure.

Series Model

These are 3 model in this thyristor units.

<single-phase>

- | | | |
|---|----------------|-------------|
| 1 | Low-end grade | PT3000S-1PH |
| 2 | Standard grade | PT3000M-1PH |
| 3 | HI-end grade | PT3200 |

<three-phase>

- | | | |
|---|----------------|----------------------|
| 1 | Low-end grade | PT3000S-3PH |
| 2 | Standard grade | PT3000M-3PH |
| 3 | HI-end grade | PT3000-E, Multidrive |



○ Citect SACDA SOFTWARE

Feature

- 1 Citect can support your system development by expanding function, reliability, great visual.
- 2 The perfect redundant functions, HMI, Server client, duplication of LAN, these functions are standard.
- 3 Hi-speed access to huge data-base with low load of CPU working.
- 4 The small system for 75 points below is matching, and the large system for 400,000 points over is possible.
- 5 It is not need to stop the operating system now for change expansion function.
- 6 License's up-grade is available

Trend display

It is possible for trend sampling method that cyclic type or situation of event causing type.
The sampling interval is setting from 10ms to 24 hours.

It is possible to change the area and graphic mode until execute the trending.

If you can push "zoom button", expand the your selecting area.

Clip-board copy function can be pasted the spread-sheet data on third-party software.

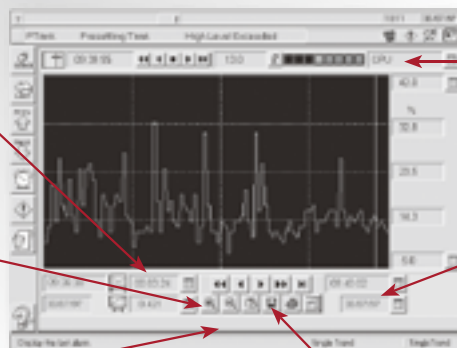

Trending display of Citect SCADA can add more trend-pen when the project is now executing.

If you can push "trend statistics button", display the minimum, maximum, average, and standard deviation.

The trending data is able to be printed that the color is direct impression display, or mono-tone display. It is possible to compose the trending figure on the Citect's report.

Specifications of PUM series

Control Module Type : PUMA/B

Process value input

No. of input	2 or 4 points (1 point/channel)
Input signal	Select from group I or II on the model code. (setting can be done according to channel with in group) Group I : Thermocouple Resistance bulb (3-wire): Pt100, JPt100 Group II : DC voltage, current DC0 to 5V, DC1 to 5V, DC0 to 10V, DC2 to 10V DC0 to 20mA, DC4 to 20mA *The power current input is external in 25ohm resistance. It's input of DC0 to 5V or DC1 to 5V Range.
Measurement range and input type	See table 1
Measurement accuracy (Ta=23°C)	Thermocouple : $\pm 0.3\%FS \pm 1\text{digit} \pm 1$ degree C or ± 3 degrees C whichever is greater *Unless B thermocouple 0 to 400 degrees C : $\pm 5\%FS \pm 1\text{digit} \pm 1$ degree C R thermocouple 0 to 500 degrees C : $\pm 1\%FS \pm 1\text{digit} \pm 1$ degree C T thermocouple -200 to 0 degree C : $\pm 0.5\%FS \pm 1\text{digit} \pm 1$ degree C Resistance bulb input : $\pm 0.3\%FS \pm 1\text{digit}$ or ± 1 degree C whichever is greater Voltage / Current input : $\pm 0.3\%FS \pm 1\text{digit}$
Resolution	See table 1
Temperature fluctuation	$\pm 0.3\%FS/10$ degrees C
Input sampling cycle	200ms
Input impedance	Thermocouple: 1M ohm or more Current input : 250 ohm Voltage input : approx. 1M ohm
Influence of signal source resistance	Thermocouple: $\pm 0.3\%FS \pm 1\text{digit} / 100$ ohm Voltage input : $\pm 0.3\%FS \pm 1\text{digit} / 500$ ohm
Allowable wiring resistance	Resistance bulb: 10 ohm or less (per wire)
Allowable input voltage	DC voltage input: within $\pm 15V$ Current input: within $\pm 25mA$ Thermocouple/resistance bulb: within $\pm 5V$
Noise rejection ratio	Normal mode: 30dB or more (50/60Hz) Common mode: 120dB or more (50/60Hz) between process value input and earth ground, power supply, output 220Vac, 50/60Hz
Input compensation	a) User adjustment: zero point, span point $\pm 50\%FS$ b) PV shift: $\pm 10\%FS$ c) First order lag filter : 0.0 to 120.0 sec.
Over range, under range	Out of range of -5 to 105%FS (Accuracy cannot be ensured for -5 to 0, 100 to 105%FS)
Insulation	Functional insulation between channels, and with any other input/output

Heater break detector (CT) input

No. of input	4 or 8 points (2 points/control ch.)
Input type	Single-phase type CT /point 1 to 30A: CTL-6-S-H 20 to 50A: CTL-12-S36-8
Current detection accuracy	Input value $\pm 10\%$ or $\pm 2A$, whichever is greater
Time required for detection	ON detection: 800 ms or more OFF detection: 2 sec. or more
Connection method	Connector for heater break detector [on the front of module]
Insulation	No insulation between channels No insulation with communication port (RS-485, loader)

Control output

No. of output	2 points (1 point/ch.) or 4 points (2 points/ch.)
Control output behavior	Heat (reverse action) or cool (direct action), or heat/cool (control output 2 points/loop required)
Output type	Selected from ① to ③ (by 2 channels) ① Relay contact output - Proportional cycle : 1 to 150 sec. - Contact structure : 1a (SPST) contact - Contact capacity : 220Vac/30Vdc, 3A (resistance load) 220Vac/30Vdc, 1A (inductive load) ② SSR/SSC drive output - Proportional cycle : 1 to 150 sec. - Minimum resolution : 5ms - ON voltage : 10Vdc (8 to 12Vdc) - OFF voltage : 0.5Vdc or less - Max. current : 20mAdc (per point) - Load resistance : 500 ohm or more - Insulation : No insulation with any other output (excluding relay output) Functional insulation with others than those above ③ Current output (4 to 20mAdc, 0 to 20mAdc) - Actual output range : 0mA to 20.6mAdc - Accuracy : $\pm 0.3\%FS$ (less than 1mA : $\pm 5\%FS$) - Linearity : $\pm 0.3\%FS$ (less than 1mA : $\pm 5\%FS$) - Resolution : 5,000 or more - Ripple current : P-P 0.3mA or less - Load resistance : 300 ohm or less - Insulation : No insulation with any other output (excluding relay output) Functional insulation with others than those above

Analog re-transmission output

No. of output	2 points (OUT3, OUT4 applied)
Output type	Current output (4 to 20mAdc, 0 to 20mAdc)
Option	Output scaling

RS-485 interface

Communication standards	RS-485 compatible
No. of port	1 port
Communication, synchro method	Two-wire, half-duplex, asynchronous cycle
Communication speed	9.6k, 19.2k, 38.4k, 115.2kbps
Communication distance	1km (38.4kbps or less), 250m (115.2kbps)
Recommended cable	KPEV-SB 0.5sq-equivalent
No. of connectable units	33 units (master and slave)(32 units if any modules other than PUM series are included in slaves.)
Data format	Data bit; 8, parity; even / odd / none
Protocol	Modbus RTU compatible
Insulation	No insulation with loader communication port, CT input. Functional insulation with any other input / output

■ Loader communication (RS-232C) interface

Communication standards	RS-232C compatible
No. of port	1 port
Communication, synchro method	Half-duplex, asynchronous cycle
Communication speed	19.2kbps (fixed)
Data format	Data bit 8, no parity
Protocol	Modbus RTU compatible
Connection method	2.5 diameter mini-plug/jack [on the front of the module] (Common cable with PXG, PXH)
Insulation	No insulation with RS-485, CT input. Functional insulation with any other input / output

■ Control functions

Control methods	(1) PID control (including FUZZY PID control)-PID constant : Set by auto tuning (2) PID 2 (Heat /cool) control (including FUZZY PID control)-PID constant : Set by auto tuning
Control parameter	Proportional band (P) : 0.0 to 999.9%, P=0: 2 position control ON Integration time (I): 0 sec to 3200 sec. I=0 : Integration OFF Derivation time (D): 0.0 to 999.9 sec. D=0: Derivation OFF Control cycle: 200ms
Control mode	Mode type: Auto / Manual / Remote Mode switching: Auto ⇄ Manual : balance less / bump less transfer Auto/Manual ⇒ Remote : balance/bump less transfer Auto/Manual ⇄ Remote : balance/bump less transfer

■ Alarm function

Alarm type	PV value (Lower/upper limit, absolute / deviation value, range) Loop burnout alarm, Error alarm, etc. (Non-excitation, delay, latch, timer function also available)
Alarm output	Data output via communication or output from event input / output module

■ Heater break alarm

No. of alarm set-points	4 or 8 points (2 points/control channel)
Alarm type	Detect when output ON (break detection) Detect when output OFF (leakage current detection) (setting can be done separately by point)
Heater current alarm	Detectable current range: 1A to 50A Detected current resolution: 0.1A Setting resolution: 0.1A Operation dead band: 0.0 to 50.0A
Alarm output	Data output via communication or output from event input / output module

■ Display, configuration

Display	Status display LED (2 colors x 6 points)
Display contents	RUN/FAULT, RS-485 TX/RX, OUT / ERR by loop (4 loops)
Setting device	Rotary SW x 1
Set contents	RS-485 Station No. (Station No.= setting value + 1) (Station No.= setting value + 17)

■ Structure

Case material	Polyphenylene oxide (flame retardant grade : UL94V-0 equivalent)
Case color	Case ; red ,Terminal, base part ; black
Protection	Body : IP20 grade protection (ventilation slits on the top and the bottom of the body) Terminal : IP00 grade protection, terminal cover is available as an option
Dimensions	30 (W) × 100 (H) × 85 (D) mm (excluding terminal cover and projected part)
Weight	Approx. 200 g
Installation method	DIN rail mounting or mounting with M3 screws inside a cabinet
Extend terminal	<ul style="list-style-type: none"> Process value input / control output : Detachable terminal block (M3 screw x 20 terminals) Power supply connection: Terminal block on the base part (M3 screw x 2 terminals) Power is supplied via side connectors in the case of lateral connecting. (Max. 16 units) RS-485 communication connection : Terminal block on the base part (M3 screw x 3 terminals) RS-485 communication is connected via side connectors in the case of lateral connecting. CT input : Special connectors (8pin×2 pcs.) [on the front of the module] Loader communication port : 2.5 diameter mini-plug / jack [on the front of the module]

■ General specification

Power supply	24Vdc±10%																
Power consumption	Max. 3.2W (135mA) [when 24Vdc is applied]																
Effect of power outage	Outage of 2ms or less ; no impact																
Memory backup	Nonvolatile memory (EEPROM) No. of update ; 100,000																
Insulation resistance	20MΩ or more (500Vdc)																
Insulation block diagram	<table border="1"> <tr> <td>Power</td> <td>PV1</td> </tr> <tr> <td>Loader communication port</td> <td>PV2</td> </tr> <tr> <td>RS-485 communication port</td> <td>PV3</td> </tr> <tr> <td>CT Input (CT1A, B - CT4A,B)</td> <td>PV4</td> </tr> <tr> <td>OUT1 (relay contact output)</td> <td>OUT1 (SSR drive, current)</td> </tr> <tr> <td>OUT2 (relay contact output)</td> <td>OUT2 (SSR drive, current)</td> </tr> <tr> <td>OUT3 (relay contact output)</td> <td>OUT3 (SSR drive, current)</td> </tr> <tr> <td>OUT4 (relay contact output)</td> <td>OUT4 (SSR drive, current)</td> </tr> </table> <p>—Basic insulation (1500VAC)=Functional insulation (1000VAC) – Functional insulation (500VAC)</p>	Power	PV1	Loader communication port	PV2	RS-485 communication port	PV3	CT Input (CT1A, B - CT4A,B)	PV4	OUT1 (relay contact output)	OUT1 (SSR drive, current)	OUT2 (relay contact output)	OUT2 (SSR drive, current)	OUT3 (relay contact output)	OUT3 (SSR drive, current)	OUT4 (relay contact output)	OUT4 (SSR drive, current)
Power	PV1																
Loader communication port	PV2																
RS-485 communication port	PV3																
CT Input (CT1A, B - CT4A,B)	PV4																
OUT1 (relay contact output)	OUT1 (SSR drive, current)																
OUT2 (relay contact output)	OUT2 (SSR drive, current)																
OUT3 (relay contact output)	OUT3 (SSR drive, current)																
OUT4 (relay contact output)	OUT4 (SSR drive, current)																

■ Normal operating condition

Ambient temperature	-10 to 50 degrees C * "Ambient temperature" is the temperature underneath the controller inside the equipment or the cabinet where the controller is installed.
Ambient humidity	90% RH or less (non condensing)
Vibration	10 to 70Hz, 9.8m/s ² (1G) or less
Warmup time	30 min. or more

■ Transporting, storage conditions (packing conditions)

Storage temperature	-20 to 60 degrees C
Ambient humidity	90%RH or less (no condensing)
Vibration	10 to 70Hz, 9.8m/s ² (1G) or less
Shock	294m/s ² (30G) or less

[Table 1] Input type and standard nput range

Input type		Input code	Measurement range [degree C]	Min. measurement [degree C]
Resistance bulb (IEC)	Pt100ohm	2	0 to 150	0.1
		3	-150 to 300	0.1
		4	-150 to 850	1
Thermocouple	J	5	0 to 400	0.1
		6	0 to 800	0.1
	K	7	0 to 400	0.1
		8	0 to 800	0.1
		9	0 to 1200	1
	R	10	0 to 1600	1
	B	11	0 to 1800	1
	S	12	0 to 1600	1
	T	13	-199 to 400	0.1
	E	14	-199 to 800	0.1
	N	18	0 to 1300	1
PL- II	19	0 to 1300	1	
DC voltage*	DC0-5V	21	-1999 to 9999 (scaling range)	-
	DC1-5V	22		
	DC0-10V	23		
	DC2-10V	24		

*In case of current input, stanch I/V unit which comes with the controller to the voltage input terminal.

■ Event Input/Output Module Type : PUME

■ Digital Input

No. of input	8 points (4points/common × 2blocks)
Input type	Voltage contact input, sink/source com-mon (bidirectional)
Input rating	24V DS, input impedance approx. 4.7Kohm
Input judgment	ON judgment: 16 to 26.4V DC OFF judgment: 0 to 5V DC
Input read cycle (min.pulse width)	200ms
Insulation	Functional insulation with internal circuit
Option	NOT/AND/OR logic operation, Latch action

■ Digital Output

No. of output	8 points (4points/common × 2blocks)
Output type	Select from a) and b) according to model type specification a) Relay contact output - Contact structure: SPST contact - Contact capacity: 220V AC/30V DA, 1A - Insulation: Functional insulation with internal circuit b) Transistor open collector (sink) output - Rating: 24V DC, 100mA (Residual voltage when power is ON: 1.5V DC or less) - Insulation: Functional insulation with internal circuit
Option	Control output/Event output selection, NOT/AND/OR logic operation, Latch action

■ RS-485 interface

Communication standards	RS-485 compatible
No. of port	1 port
Communication, synchro method	Two-wire, half-duplex, asynchronous cycle
Communication speed	9.6k, 19.2k, 38.4k, 115.2kbps
Communication distance	1km (38.4kbps or less), 250m (115.2kbps)
Recommended cable	KPEV-SB 0.5sq-equivalent
No. of connectable units	33 units (master and slave)(32 units if any modules other than PUM series are included in slaves.)
Data format	Data bit; 8, parity; even / odd / none
Protocol	Modbus RTU compatible
Insulation	No insulation with loader communication port. Functional insulation with any other input/output

■ Loader communication (RS-232C) interface

Communication standards	RS-232C compatible
No. of port	1 port
Communication, synchro method	Half-duplex, asynchronous cycle
Communication speed	19.2kbps (fixed)
Data format	Data bit 8, no parity
Protocol	Modbus RTU compatible
Connection method	2.5 diameter mini-plug/jack [on the front of the module] (Common cable with PXG, PXH)
Insulation	No insulation with RS-485 Functional insulation with any other input/output

■ Display, configuration

Display	Status display LED (2 colors × 2 points + 16 points)
Display contents	RUN/FAULT, RS-485 TX/RX, input × 8 points output × 8 points
Setting device	Rotary SW × 1 [on the front of the module]
Set contents	RS-485 Station No. (Station No. = setting value + 17)

■ Structure

Case material	Polyphenylene oxide (flame retardant grade : UL94V-0 equivalent)
Case color	Case ; red , Terminal, base part ; black
Protection	Body : IP20 grade protection (ventilation slits on the top and the bottom of the body) Terminal : IP00 grade protection, terminal cover is available as an option
Dimensions	30(W)×100(H)×85(D) mm(excluding terminal cover and projected part)
Weight	Approx. 200 g
Installation method	DIN rail mounting or mounting with M3 screws inside a cabinet
External terminal	<ul style="list-style-type: none"> Digital input / digital output : Detachable terminal block (M3 screw × 20 terminals) Power supply connection: Terminal block on the base part (M3 screw × 2 terminals) Power is supplied via side connectors in the case of lateral connecting. (Max. 33 units) RS-485 communication connection : Terminal block on the base part (M3 screw × 3 terminals) RS-485 communication is connected via side connectors in the case of lateral connecting. CT input: Special connectors (8pin × 2) [on the front of the module] Loader communication port : 2.5 diameter mini-plug / jack [on the front of the module]

■ General specification

Power supply	24Vdc±10%								
Power consumption	Max. 3.2W (135mA) [when 24Vdc is applied]								
Effect of power outage	Outage of 2ms or less ; no impact								
Memory backup	Nonvolatile memory (EEPROM) No. of update ; 100,000								
Insulation resistance	20MΩ or more (500Vdc)								
Insulation block diagram	<table border="1"> <tr> <td>Power</td> <td>Di1 to 4</td> </tr> <tr> <td>Loader communication port</td> <td>Di5 to 8</td> </tr> <tr> <td>RS-485 communication port</td> <td>Do1 to 4</td> </tr> <tr> <td></td> <td>Do5 to 8</td> </tr> </table> <p>=Functional insulation (1000VAC)-Functional insulation (500VAC)</p>	Power	Di1 to 4	Loader communication port	Di5 to 8	RS-485 communication port	Do1 to 4		Do5 to 8
Power	Di1 to 4								
Loader communication port	Di5 to 8								
RS-485 communication port	Do1 to 4								
	Do5 to 8								

■ Normal operating condition

Ambient temperature	-10 to 50 degrees C * "Ambient temperature" is the temperature underneath the controller inside the equipment or the cabinet where the controller is installed.
Ambient humidity	90%RH or less (no condensing)
Vibration	10 to 70Hz, 9.8m/s ² (1G) or less
Warmup time	30 min. or more

■ Transporting, storage conditions (packing conditions)

Storage temperature	-20 to 60 degrees C
Ambient humidity	90%RH or less (no condensing)
Vibration	10 to 70Hz, 9.8m/s ² (1G) or less
Shock	294m/s ² (30G) or less

■ Analog Input/Output Module Type : PUMV

■ Analog Input

No. of input	4 points
Input signal	Select from the group I or II depending on the model code. Group I: Thermocouple: K, J, T, E, R, B, S, N, PL-II Resistance bulb (3-wire): Pt100, JPt100 Group II : DC voltage, current DC0 to 5V, DC1 to 5V, DC0 to 10V, DC2 to 10V DC0 to 20mA, DC4 to 20mA *The power current input is external in 250ohm resistance. It's input of DC0 to 5V or DC1 to 5V Range.
Measurement range and input type	See table 1
Measurement accuracy (Ta=23°C)	Thermocouple input : $\pm 0.3\%FS \pm 1\text{digit} \pm 1$ degree C or ± 3 degrees C whichever is greater *Unless B thermocouple 0 to 400 degrees C : $\pm 5\%FS \pm 1\text{digit} \pm 1$ degree C R thermocouple 0 to 500 degrees C : $\pm 1\%FS \pm 1\text{digit} \pm 1$ degree C T thermocouple -200 to 0 degree C : $\pm 0.5\%FS \pm 1\text{digit} \pm 1$ degree C Resistance bulb input : $\pm 0.3\%FS \pm 1\text{digit}$ or ± 1 degree C whichever is greater Voltage input : $\pm 0.3\%FS \pm 1\text{digit}$
Resolution	See table 1
Temperature fluctuation	$\pm 0.3\%FS/10$ degrees C
Input sampling cycle	200ms
Input impedance	Thermocouple: 1M ohm or more Current input : 250 ohm Voltage input : approx. 1M ohm
Influence of signal source resistance	Thermocouple: $\pm 0.3\%FS \pm 1\text{digit} / 100$ ohm Voltage input : $\pm 0.3\%FS \pm 1\text{digit} / 500$ ohm
Allowable wiring resistance	Resistance bulb input: 10 ohm or less (per wire)
Allowable input voltage	DC voltage input: within $\pm 15V$ Current input: within $\pm 25mA$ Thermocouple/resistance bulb: within $\pm 5V$
Noise rejection ratio	Normal mode: 30dB or more (50/60Hz) Common mode: 120dB or more (50/60Hz) between earth, power supply, output 220Vac, 50/60Hz
Input compensation	a) User adjustment: zero point, span point $\pm 50\%FS$ b) PV shift: $\pm 10\%FS$ c) First order lag filter : 0.0 to 120.0 sec. (Filter off when setting is 0.0)
Over range, under range	Out of range of -5 to 105%FS (Accuracy cannot be ensured for -5 to 0, 100 to 105%FS)
Insulation	Functional insulation between channels, and with any other input/output

■ Analog Output

No. of output	4 points
Output type	Current output DC 4 to 20mA, DC 0 to 20mA
Actual output range	DC 0mA to 20.6mA
Accuracy	$\pm 0.3\%FS$ (less than 1mA : $\pm 5\%FS$)
Linearity	$\pm 0.3\%FS$ (less than 1mA : $\pm 5\%FS$)
Resolution	5,000 or more
Ripple current	P-P 0.3mA or less
Loading resistance	300 ohm or less
Insulation	No insulation with any other output Function insulation with others than those above (power supply, analog input, RS485 communication, and loader port)

■ RS-485 interface

Communication standards	RS-485 compatible
No. of port	1 port
Communication, synchro method	Two-wire, half-duplex, asynchronous cycle
Communication speed	9.6k, 19.2k, 38.4k, 115.2kbps
Communication distance	1km (38.4kbps or less), 250m (115.2kbps)
Recommended cable	KPEV-SB 0.5sq-equivalent
No. of connectable units	33 units (master and slave)(32 units if any modules other than PUM series are included in slaves.)
Data format	Data bit; 8, parity; even / odd / none
Protocol	Modbus RTU compatible
Insulation	No insulation with loader communication port, CT input. Functional insulation with any other input / output

■ Loader communication (RS-232C) interface

Communication standards	RS-232C compatible
No. of port	1 port
Communication, synchro method	Half-duplex, asynchronous cycle
Communication speed	19.2kbps (fixed)
Data format	Data bit 8, no parity
Protocol	Modbus RTU compatible
Connection method	2.5 diameter mini-plug/jack [on the front of the module] (Common cable with PXG, PXH)
Insulation	No insulation with RS-485, CT input. Functional insulation with any other input / output

■ Display, configuration

Display	Status display LED (2 colors x 6 points)
Display contents	RUN/FAULT, RS-485 TX/RX, OUT / ERR by loop (4 loops)
Setting device	Rotary SW x 1
Set contents	RS-485 Station No. (Station No.= setting value + 1)

Structure

Case material	Polyphenylene oxide (flame retardant grade : UL94V-0 equivalent)
Case color	Case ; red , Terminal, base part ; black
Protection	Body : IP20 grade protection (ventilation slits on the top and the bottom of the body) Terminal : IP00 grade protection, terminal cover is available as an option
Dimensions	30 (W) × 100 (H) × 85 (D) mm (excluding terminal cover)
Weight	Approx. 200 g
Installation method	DIN rail mounting or mounting with M3 screws inside a cabinet
External terminal	<ul style="list-style-type: none"> · Process value input / control output : Detachable terminal block (M3 screw x 20 terminals) · Power supply connection: Terminal block on the base part (M3 screw x 2 terminals) Power is supplied via side connectors in the case of lateral connecting. (Max. 16 units) · RS-485 communication connection : Terminal block on the base part (M3 screw x 3 terminals) RS-485 communication is connected via side connectors in the case of lateral connecting. · CT input : Special connectors (8pin×2 pcs.) [on the front of the module] · Loader communication port : 2.5 diameter mini-plug / jack [on the front of the module]

General specification

Power supply	24Vdc±10%							
Power consumption	Max. 3.2W (135mA) [when 24Vdc is applied]							
Effect of power outage	Outage of 2ms or less ; no impact							
Memory backup	Nonvolatile memory (EEPROM) No. of update ; 100,000							
Insulation resistance	20MΩ or more (500Vdc)							
Insulation block diagram	<table border="1" style="width: 100%;"> <tr> <td style="width: 50%;">Power</td> <td>PV1</td> </tr> <tr> <td rowspan="4">Loader communication port RS-485 communication port</td> <td>PV2</td> </tr> <tr> <td>PV3</td> </tr> <tr> <td>PV4</td> </tr> <tr> <td>OUT1 (current) OUT2 (current) OUT3 (current) OUT4 (current)</td> </tr> </table> <p>=Functional insulation (1000VAC)–Functional insulation (500VAC)</p>	Power	PV1	Loader communication port RS-485 communication port	PV2	PV3	PV4	OUT1 (current) OUT2 (current) OUT3 (current) OUT4 (current)
Power	PV1							
Loader communication port RS-485 communication port	PV2							
	PV3							
	PV4							
	OUT1 (current) OUT2 (current) OUT3 (current) OUT4 (current)							

Normal operating condition

Ambient temperature	-10 to 50 degrees C * "Ambient temperature" is the temperature underneath the controller inside the equipment or the cabinet where the controller is installed.
Ambient humidity	90%RH or less (no condensing)
Vibration	10 to 70Hz, 9.8m/s ² (1G) or less
Warmup time	30 min. or more

Transporting, storage conditions (packing conditions)

Storage temperature	-20 to 60 degrees C
Ambient humidity	90%RH or less (no condensing)
Vibration	10 to 70Hz, 9.8m/s ² (1G) or less
Shock	294m/s ² (30G) or less

■ Analog Input Module Type : PUMN

■ Analog Input

No. of input	4 points
Input signal	Select from group I or II on the model code. Group I: Thermocouple: K, J, T, E, R, B, S, N, PL-II Resistance bulb (3-wire) : Pt100, JPt100 Group II : DC voltage, current DC0 to 5V, DC1 to 5V, DC0 to 10V, DC2 to 10V DC0 to 20mA, DC4 to 20mA *The power current input is external in 250ohm resistance. It's input of DC0 to 5V or DC1 to 5V Range.
Measurement range and input type	See table 1
Measurement accuracy (Ta=23°C)	Thermocouple input: : $\pm 0.3\%FS \pm 1 \text{ digit} \pm 1 \text{ degree C}$ or $\pm 3 \text{ degrees C}$ whichever is greater *Unless B thermocouple 0 to 400 degrees C : $\pm 5\%FS \pm 1 \text{ digit} \pm 1 \text{ degree C}$ R thermocouple 0 to 500 degrees C : $\pm 1\%FS \pm 1 \text{ digit} \pm 1 \text{ degree C}$ T thermocouple -200 to 0 degree C : $\pm 0.5\%FS \pm 1 \text{ digit} \pm 1 \text{ degree C}$ Resistance bulb input : $\pm 0.3\%FS \pm 1 \text{ digit}$ or ± 1 degree C whichever is greater Voltage input : $\pm 0.3\%FS \pm 1 \text{ digit}$
Resolution	See table 1
Temperature fluctuation	$\pm 0.3\%FS/10 \text{ degrees C}$
Input sampling cycle	200ms
Input impedance	Thermocouple: 1M ohm or more Current input : 250 ohm Voltage input : approx. 1M ohm
Influence of signal source resistance	Thermocouple: $\pm 0.3\%FS \pm 1 \text{ digit} / 100 \text{ ohm}$ Voltage input : $\pm 0.3\%FS \pm 1 \text{ digit} / 500 \text{ ohm}$
Allowable wiring resistance	Resistance bulb input: 10 ohm or less (per wire)
Allowable input voltage	DC voltage input: within $\pm 15V$ Current input: within $\pm 25mA$ Thermocouple/resistance bulb: within $\pm 5V$
Noise rejection ratio	Normal mode: 30dB or more (50/60Hz) Common mode: 120dB or more (50/60Hz) between process value input and earth ground, power supply, output 220Vac, 50/60Hz
Input compensation	a) User adjustment: zero point, span point $\pm 50\%FS$ b) PV shift: $\pm 10\%FS$ c) First order lag filter : 0.0 to 120.0 sec. (filter off when setting is 0.0)
Over range, under range	Out of range of -5 to 105%FS (Accuracy cannot be ensured for -5 to 0, 100 to 105%FS)
Insulation	Functional insulation between channels, and with any other input/output

■ RS-485 interface

Communication standards	RS-485 compatible
No. of port	1 port
Communication, synchro method	Two-wire, half-duplex, asynchronous cycle
Communication speed	9.6k, 19.2k, 38.4k, 115.2kbps
Communication distance	1km (38.4kbps or less), 250m (115.2kbps)
Recommended cable	KPEV-SB 0.5sq-equivalent
No. of connectable units	33 units (master and slave)(32 units if any modules other than PUM series are included in slaves.)
Data format	Data bit; 8, parity; even / odd / none
Protocol	Modbus RTU compatible
Insulation	No insulation with loader communication port Functional insulation with any other input/output

■ Loader communication (RS-232C) interface

Communication standards	RS-232C compatible
No. of port	1 port
Communication, synchro method	Half-duplex, asynchronous cycle
Communication speed	19.2kbps (fixed)
Data format	Data bit 8, no parity
Protocol	Modbus RTU compatible
Connection method	2.5 diameter mini-plug/jack [on the front of the module] (Common cable with PXG, PXH)
Insulation	No insulation with RS-485 Functional insulation with any other input/output

■ Display, configuration

Display	Status display LED (2 colors x 2 points + 4points)
Display contents	RUN/FAULT, RS-485 TX/RX, Input ERR/Output by loop
Setting device	Rotary SW x 1
Set contents	RS-485 Station No. (Station No.= setting value + 1)

■ Structure

Case material	Polyphenylene oxide (flame retardant grade : UL94V-0 equivalent)
Case color	Case ; red , Terminal, base part ; black
Protection	Body : IP20 grade protection (ventilation slits on the top and the bottom of the body) Terminal : IP00 grade protection, terminal cover is available as an option
Dimensions	30 (W) x 100 (H) x 85 (D) mm (excluding terminal cover)
Weight	Approx. 200 g
Installation method	DIN rail mounting or mounting with M3 screws inside a cabinet
External terminal	<ul style="list-style-type: none"> Process value input / control output : Detachable terminal block (M3 screw x 20 terminals) Power supply connection: Terminal block on the base part (M3 screw x 2 terminals) Power is supplied via side connectors in the case of lateral connecting. (Max. 16 units) RS-485 communication connection : Terminal block on the base part (M3 screw x 3 terminals) RS-485 communication is connected via side connectors in the case of lateral connecting. Loader communication port : 2.5 diameter mini- plug / jack [on the front of the module]*

■ General specification

Power supply	24Vdc $\pm 10\%$								
Power consumption	Max. 3.2W (135mA) [when 24Vdc is applied]								
Effect of power outage	Outage of 2ms or less ; no impact								
Memory backup	Nonvolatile memory (EEPROM) No. of update ; 100,000								
Insulation resistance	20M Ω or more (500Vdc)								
Insulation block diagram	<table border="1"> <tr> <td>Power</td> <td>PV1</td> </tr> <tr> <td>Loader communication port</td> <td>PV2</td> </tr> <tr> <td>RS-485 communication port</td> <td>PV3</td> </tr> <tr> <td></td> <td>PV4</td> </tr> </table>	Power	PV1	Loader communication port	PV2	RS-485 communication port	PV3		PV4
Power	PV1								
Loader communication port	PV2								
RS-485 communication port	PV3								
	PV4								

=Functional insulation (1000VAC)–Functional insulation (500VAC)

■ Normal operating condition

Ambient temperature	-10 to 50 degrees C * "Ambient temperature" is the temperature underneath the controller inside the equipment or the cabinet where the controller is installed.
Ambient humidity	90%RH or less (no condensing)
Vibration	10 to 70Hz, 9.8m/s ² (1G) or less
Warmup time	30 min. or more

■ Transporting, storage conditions (packing conditions)

Storage temperature	-20 to 60 degrees C
Ambient humidity	90%RH or less (no condensing)
Vibration	10 to 70Hz, 9.8m/s ² (1G) or less
Shock	294m/s ² (30G) or less

■ Analog Output Module Type : PUMT

■ Analog Output

No. of output	4 points
Output type	Current output DC 4 to 20mA, DC 0 to 20mA
Actual output range	DC 0mA to 20.6mA
Accuracy	±0.3%FS (less than 1mA : ±5%FS)
Linearity	±0.3%FS (less than 1mA : ±5%FS)
Resolution	5,000 or more
Ripple current	P-P 0.3mA or less
Loading resistance	300 ohm or less
Insulation	No insulation with any other output (power source, analog input, RS485 communication and loader port) Functional insulation with others than those above

■ RS-485 interface

Communication standards	RS-485 compatible
No. of port	1 port
Communication, synchro method	Two-wire, half-duplex, asynchronous cycle
Communication speed	9.6k, 19.2k, 38.4k, 115.2kbps
Communication distance	1km (38.4kbps or less), 250m (115.2kbps)
Recommended cable	KPEV-SB 0.5sq-equivalent
No. of connectable units	33 units (master and slave)(32 units if any modules other than PUM series are included in slaves.)
Data format	Data bit; 8, parity; even / odd / none
Protocol	Modbus RTU compatible
Insulation	No insulation with loader communication port Functional insulation with any other input/output

■ Loader communication (RS-232C) interface

Communication standards	RS-232C compatible
No. of port	1 port
Communication, synchro method	Half-duplex, asynchronous cycle
Communication speed	19.2kbps (fixed)
Data format	Data bit 8, no parity
Protocol	Modbus RTU compatible
Connection method	2.5 diameter mini-plug/jack [on the front of the module] (Common cable with PXG, PXH)
Insulation	No insulation with RS485 Functional insulation with any other input/output

■ Display, configuration

Display	Status display LED (2 colors x 2 points + 4points)
Display contents	RUN/FAULT, RS-485 TX/RX, Input ERR/Output by loop
Setting device	Rotary SW x 1
Set contents	RS-485 Station No. (Station No.= setting value + 1)

■ Structure

Case material	Polyphenylene oxide (flame retardant grade : UL94V-0 equivalent)
Case color	Case ; red , Terminal, base part ; black
Protection	Body : IP20 grade protection (ventilation slits on the top and the bottom of the body) Terminal : IP00 grade protection, terminal cover is available as an option
Dimensions	30 (W) × 100 (H) × 85 (D) mm (excluding terminal cover)
Weight	Approx. 200 g
Installation method	DIN rail mounting or mounting with M3 screws inside a cabinet
External terminal	<ul style="list-style-type: none"> Process value input / control output : Detachable terminal block (M3 screw x 20 terminals) Power supply connection: Terminal block on the base part (M3 screw x 2 terminals) Power is supplied via side connectors in the case of lateral connecting. (Max. 16 units) RS-485 communication connection : Terminal block on the base part (M3 screw x 3 terminals) RS-485 communication is connected via side connectors in the case of lateral connecting. Loader communication port : 2.5 diameter mini-plug / jack [on the front of the module]*

■ General specification

Power supply	24Vdc±10%								
Power consumption	Max. 3.2W (135mA) [when 24Vdc is applied]								
Effect of power outage	Outage of 2ms or less ; no impact								
Memory backup	Nonvolatile memory (EEPROM) No. of update ; 100,000								
Insulation resistance	20MQ or more (500Vdc)								
Insulation block diagram	<table border="1"> <tr> <td>Power</td> <td>OUT1 (current)</td> </tr> <tr> <td>Loader communication port</td> <td>OUT2 (current)</td> </tr> <tr> <td>RS-485 communication port</td> <td>OUT3 (current)</td> </tr> <tr> <td></td> <td>OUT4 (current)</td> </tr> </table> <p>=Functional insulation (1000VAC)–Functional insulation (500VAC)</p>	Power	OUT1 (current)	Loader communication port	OUT2 (current)	RS-485 communication port	OUT3 (current)		OUT4 (current)
Power	OUT1 (current)								
Loader communication port	OUT2 (current)								
RS-485 communication port	OUT3 (current)								
	OUT4 (current)								

■ Normal operating condition

Ambient temperature	-10 to 50 degrees C * "Ambient temperature" is the temperature underneath the controller inside the equipment or the cabinet where the controller is installed.
Ambient humidity	90%RH or less (no condensing)
Vibration	10 to 70Hz, 9.8m/s ² (1G) or less
Warmup time	30 min. or more

■ Transporting, storage conditions (packing conditions)

Storage temperature	-20 to 60 degrees C
Ambient humidity	90%RH or less (no condensing)
Vibration	10 to 70Hz, 9.8m/s ² (1G) or less
Shock	294m/s ² (30G) or less

High-speed communication Module Type:PUMCR

RS485 communication

Communication standards	RS-485 compatible
No. of port	2port (Port1, Port2)
Communication, synchro method	Two-wire, half-duplex, asynchronous cycle
Communication speed	9.6k, 19.2k, 38.4k, 115.2k, 230.4kbps
Communication distance	within 1km (38.4kbps or less) 250m (115.2kbps or more)
Recommended cable	KPEV-SB 0.5sq-equivalent
Data format	Start bit 1, Data bit; 7/8 parity; even/odd/none Stop bit 1
Protocol	Modbus RTU compatible
Insulation	No insulation with port, Functional insulation with any other signal
Function	master or slave

RS232-C communication

Communication standards	RS-232 compatible
No. of port	1port (Port1 only, Selection of the parameter setup with RS-485)
Communication, synchro method	Two-wire, asynchronous cycle
Communication speed	9.6k, 19.2k, 38.4k, 115.2k, 230.4kbps
Data format	Start bit 1, Data bit; 7/8 parity; even/odd/none Stop bit 1
Protocol	Modbus RTU compatible
Insulation	No insulation with port, Functional insulation with any other signal
Function	master or slave

Loader communication (RS-232C) interface

Communication standards	RS-232C compatible
No. of port	1 port
Communication, synchro method	Half-duplex, asynchronous cycle
Communication speed	19.2kbps (fixed)
Data format	Data bit 8, no parity
Protocol	Modbus RTU compatible
Connection method	2.5 diameter mini-plug/jack [on the front of the module] (Common cable with PXG, PXH)
Insulation	Functional insulation with any other input/output

Display, configuration

Display	Status display LED (2 colors x 2 points + 4points)
Display contents	RUN/FAULT, RS-485 TX/RX, Input ERR/Output by loop
Setting device	Rotary SW x 1
Set contents	RS-485 Station No. (Station No.= setting value + 1)

Structure

Case material	Polyphenylene oxide (flame retardant grade : UL94V-0 equivalent)
Case color	Case ; red , Terminal, base part ; black
Protection	Body : IP20 grade protection (ventilation slits on the top and the bottom of the body) Terminal : IP00 grade protection, terminal cover is available as an option
Dimensions	30 (W) × 100 (H) × 85 (D) mm (excluding terminal cover)
Weight	Approx. 200 g
Installation method	DIN rail mounting or mounting with M3 screws inside a cabinet
External terminal	<ul style="list-style-type: none"> Communication Port1, Port2: Detachable terminal block (M3 screw x 20 terminals) Power supply connection: Terminal block on the base part (M3 screw x 2 terminals) Power is supplied via side connectors in the case of lateral connecting. (Max. 16 units) RS-485 communication is connected via side connectors in the case of lateral connecting. Loader communication port : 2.5 diameter mini-plug / jack [on the front of the module]"

General specification

Power supply	24Vdc±10%				
Power consumption	Max. 3.2W (135mA) [when 24Vdc is applied]				
Effect of power outage	Outage of 2ms or less ; no impact				
Memory backup	Nonvolatile memory (EEPROM) No. of update ; 100,000				
Insulation resistance	20MΩ or more (500Vdc)				
Insulation block diagram	<table border="1" style="margin-left: 20px;"> <tr> <td>Power</td> <td>Communication Port1</td> </tr> <tr> <td>Loader communication port</td> <td>Communication Port2</td> </tr> </table> <p>= Functional insulation (1000VAC)–Functional insulation (500VAC)</p>	Power	Communication Port1	Loader communication port	Communication Port2
Power	Communication Port1				
Loader communication port	Communication Port2				

Normal operating condition

Ambient temperature	-10 to 50 degrees C * "Ambient temperature" is the temperature underneath the controller inside the equipment or the cabinet where the controller is installed.
Ambient humidity	90%RH or less (no condensing)
Vibration	10 to 70Hz, 9.8m/s ² (1G) or less
Warmup time	30 min. or more

Transporting, storage conditions (packing conditions)

Storage temperature	-20 to 60 degrees C
Ambient humidity	90%RH or less (no condensing)
Vibration	10 to 70Hz, 9.8m/s ² (1G) or less
Shock	294m/s ² (30G) or less

■CC-Link Communication Module Type:PUMCL

■CC-Link Communication

Version	CC-Link Ver. 2.00/1.10					
Kind of device	Remote device					
Communication speed or Communication distance	Communication speed	156kbps	625kbps	2.5Mbps	5Mbps	10Mbps
	Total extension distance	1200m or less	900m or less	400m or less	200m or less	100m or less
Shared units/ Station numbers for communication data length	Shared 4 stations / providing number 1 to 61					
	Shared stations/ extended cyclic	Remote I/O (RX/Ry)	Remote Register (RWr/RWw)	Control Module PUMA		
	4 stations × 1	Each 128bit	16 word	2 or 4 units		
	4 stations × 2	Each 256bit	32 word	4 or 8 units		
4 stations × 4	Each 512bit	64 word	8 or 16 units			
Connection cable	CC-Link original cable for version 1.10					
Connection method	M3 screw x 3 terminals base					
Terminating resistor	External type (110 ohm, 1/2W)					

■Loader communication (RS-232C) interface

Communication standards	RS-232C compatible
No. of port	1 port
Communication, synchro method	Half-duplex, asynchronous cycle
Communication speed	19.2kbps (fixed)
Data format	Data bit 8, no parity
Protocol	Modbus RTU compatible
Connection method	2.5 diameter mini-plug/jack [on the front of the module] (Common cable with PXG, PXH)
Insulation	Functional insulation with any other input/output

■Display, configuration

Display	Status display LED (2 colors x 2 points + 4points)		
Display contents	RUN/FAULT Control Module Connection status (TX/RX) CC-Link status (L.RUN, L.ERR, SD, RD)		
Setting device or Set contents	Setting device		Set contents
	Front	Rotatory SW×2	CC-Link Setting Station numbers
	Equipment interior	Rotatory SW×1	CC-Link Setting Communication speed
		Dip SW (6bit)×1	CC-Link Setting mode

■Structure

Case material	Polyphenylene oxide (flame retardant grade : UL94V-0 equivalent)
Case color	Case ; red ,Terminal, base part ; black
Protection	Body : IP20 grade protection (ventilation slits on the top and the bottom of the body) Terminal : IP00 grade protection, terminal cover is available as an option
Dimensions	30 (W) × 100 (H) × 85 (D) mm (excluding terminal cover)
Weight	Approx. 200 g
Installation method	DIN rail mounting or mounting with M3 screws inside a cabinet
External terminal	<ul style="list-style-type: none"> · CC-Link communication terminal: Detachable terminal block (M3 screw x 20 terminals) · Power supply connection: Terminal block on the base part (M3 screw x 2 terminals) Power is supplied via side connectors in the case of lateral connecting. (Max. 16 units) · RS-485 communication is connected via side connectors in the case of lateral connecting. · Loader communication port : 2.5 diameter mini-plug / jack [on the front of the module]"

■General specification

Power supply	24Vdc±10%				
Power consumption	Max. 3.2 W(135 mA) [when 24Vdc is applied]				
Effect of power outage	Outage of 2ms or less ; no impact				
Memory backup	Nonvolatile memory (EEPROM) No. of update ; 100,000				
Insulation resistance	20MΩ or more (500Vdc)				
Insulation block diagram	<table border="1"> <tr> <td>Power</td> <td>SLD/FG terminal (CC-Link connecting terminal)</td> </tr> <tr> <td>Loader communication port</td> <td>CC-Link communication</td> </tr> </table>	Power	SLD/FG terminal (CC-Link connecting terminal)	Loader communication port	CC-Link communication
	Power	SLD/FG terminal (CC-Link connecting terminal)			
Loader communication port	CC-Link communication				
=Basic insulation (1000VAC)—Functional insulation (500VAC)—Functional insulation (50VAC)					

■Normal operating condition

Ambient temperature	-10 to 50 degrees C * "Ambient temperature" is the temperature underneath the controller inside the equipment or the cabinet where the controller is installed.
Ambient humidity	90%RH or less (no condensing)
Vibration	10 to 70Hz, 9.8m/s ² (1G) or less
Warmup time	30 min. or more

■Transporting, storage conditions (packing conditions)

Storage temperature	-20 to 60 degrees C
Ambient humidity	90%RH or less (no condensing)
Vibration	10 to 70Hz, 9.8m/s ² (1G) or less
Shock	294m/s ² (30G) or less

■ Mitsubishi PLC program less communication Module Type:PUMCM

■ RS-485 / RS422 communication

Communication standards	RS-485/RS422 compatible
No. of port	2 ports (Port1, Port2) (Port1 for RS-422)
Communication, synchro method	Two-wire, half-duplex, asynchronous cycle
Communication speed	9.6k, 19.2k, 38.4k, 115.2k, 230.4kbps
Communication distance	1km (38.4kbps or less), 250m (115.2kbps)
Recommended cable	KPEV-SB 0.5sq-equivalent
Data format	Start bit 1, Data bit; 7/8 parity; even/odd/none Stop bit 1
Protocol	MC protocol (type 5)
Insulation	No insulation with port, Functional insulation with any other signal
Function	MELSEC-Q series of PLC and program less communication

■ RS232-C communication

Communication standards	RS-232 compatible
No. of port	1 port (Port1 only, Selection of the parameter set up with RS-485, and RS-422)
Communication, synchro method	Two-wire, half-duplex, asynchronous cycle
Communication speed	9.6k, 19.2k, 38.4k, 115.2k, 230.4kbps
Data format	Start bit 1, Data bit; 7/8 parity; even/odd/none Stop bit 1
Protocol	MC protocol (type 5)
Insulation	No insulation with port, Functional insulation with any other signal
Function	MELSEC series of PLC and program less communication

■ Loader communication (RS-232C) interface

Communication standards	RS-232C compatible
No. of port	1 port
Communication, synchro method	Half-duplex, asynchronous cycle
Communication speed	19.2kbps (fixed)
Data format	Data bit 8, no parity
Protocol	Modbus RTU compatible
Connection method	2.5 diameter mini-plug/jack [on the front of the module] (Common cable with PXG, PXH)
Insulation	Functional insulation with any other input/output

■ Display, configuration

Display	Status display LED (2 colors x 2 points + 4points)
Display contents	RUN/FAULT, Port1 TX/RX, Port2 TX/RX
Setting device	Rotary SW x 1
Set contents	RS-485/RS-422 Station No. (Station No. = setting value + 1)

■ Structure

Case material	Polyphenylene oxide (flame retardant grade : UL94V-0 equivalent)
Case color	Case ; red ,Terminal, base part ; black
Protection	Body : IP20 grade protection (ventilation slits on the top and the bottom of the body) Terminal : IP00 grade protection, terminal cover is available as an option
Dimensions	30 (W) × 100 (H) × 85 (D) mm (excluding terminal cover)
Weight	Approx. 200 g
Installation method	DIN rail mounting or mounting with M3 screws inside a cabinet
External terminal	<ul style="list-style-type: none"> Communication Port1, Port2: Detachable terminal block (M3 screw x 20 terminals) Power supply connection: Terminal block on the base part (M3 screw x 2 terminals) Power is supplied via side connectors in the case of lateral connecting. (Max. 16 units) RS-485 communication is connected via side connectors in the case of lateral connecting. Loader communication port : 2.5 diameter mini-plug / jack [on the front of the module]"

■ General specification

Power supply	24Vdc±10%				
Power consumption	Max. 3.2W (135mA) [when 24Vdc is applied]				
Effect of power outage	Outage of 2ms or less ; no impact				
Memory backup	Nonvolatile memory (EEPROM) No. of update ; 100,000				
Insulation resistance	20MΩ or more (500Vdc)				
Insulation block diagram	<table border="1" style="width: 100%;"> <tr> <td style="width: 50%; text-align: center;">Power</td> <td style="width: 50%; text-align: center;">Communication Port1</td> </tr> <tr> <td style="text-align: center;">Loader communication</td> <td style="text-align: center;">Communication Port2</td> </tr> </table> <p>= Functional insulation (1000VAC)–Functional insulation (500VAC)</p>	Power	Communication Port1	Loader communication	Communication Port2
Power	Communication Port1				
Loader communication	Communication Port2				

■ Normal operating condition

Ambient temperature	-10 to 50 degrees C * "Ambient temperature" is the temperature underneath the controller inside the equipment or the cabinet where the controller is installed.
Ambient humidity	90%RH or less (no condensing)
Vibration	10 to 70Hz, 9.8m/s ² (1G) or less
Warmup time	30 min. or more

■ Transporting, storage conditions (packing conditions)

Storage temperature	-20 to 60 degrees C
Ambient humidity	90%RH or less (no condensing)
Vibration	10 to 70Hz, 9.8m/s ² (1G) or less
Shock	294m/s ² (30G) or less

○ OUTLINE DIAGRAM (Unit:mm)

CODE: PUMA/B/V/N/T/C

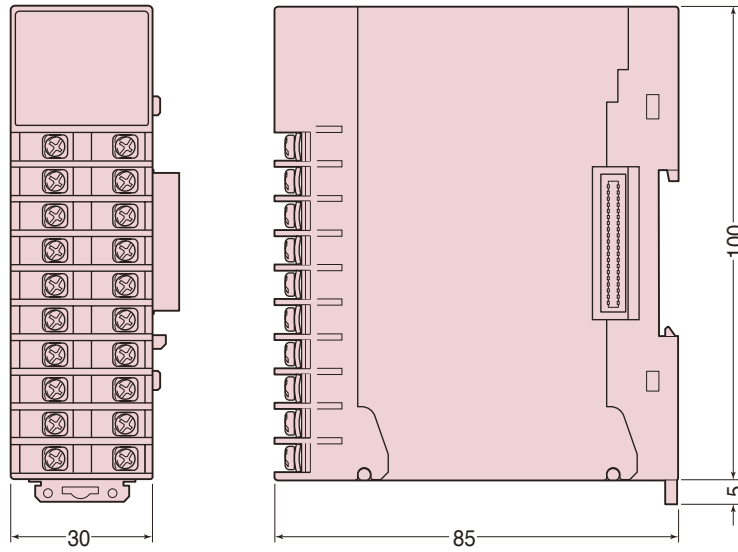

○ PART NAMES AND FUNCTIONS

Main unit

CODE: PUMA/B

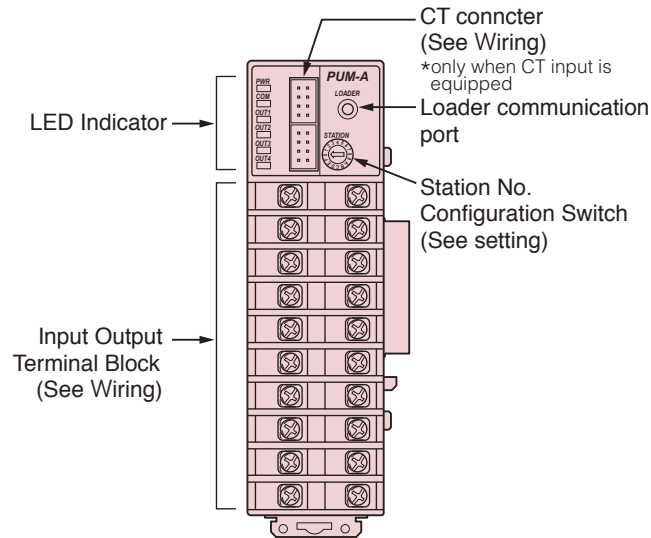

LED Indicator Six LED lamps indicate the following operational conditions

LED	LED Status	Color	Operational condition
PWR	Illuminated	green	Normal operation (Slave station of internal communication)
	Blinking	green	Normal operation (Master station of internal communication)
	Illuminated	red	System fault (A/D converter error, internal communication error)
	Blinking	red	Input error
COM	Illuminated	green	RS485 receiving
	Illuminated	orange	RS485 transmitting
OUT1-4	Illuminated	green	Corresponding channel outputting
	Illuminated	red	Corresponding channel input error

Actions to be displayed for COM and OUT1-4 can be allocated with using parameter

CODE: PUME

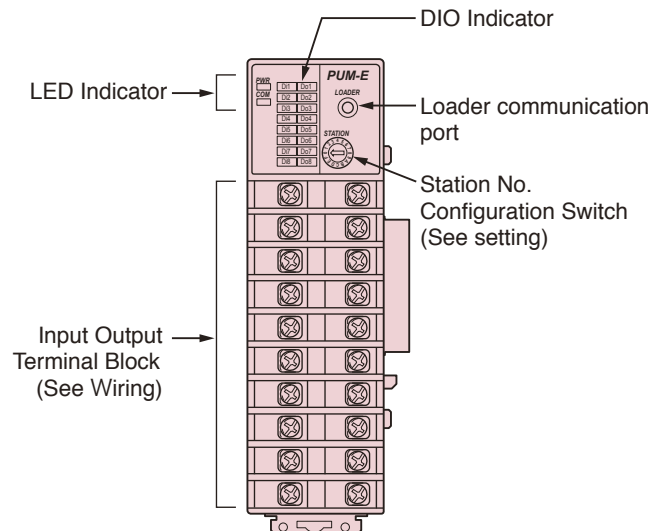

LED Indicator Six LED lamps indicate the following operational conditions

LED	GREEN	RED	ORANGE
PWR	RUN	Error	—
COM	RS485 receiving	Error	RS485 transmitting
Di1-8	Digital inputting		
Do1-8	Digital outputting		

Actions to be displayed for COM Di1-8 and Do1-8 can be allocated by programming

CODE: PUMV/NT

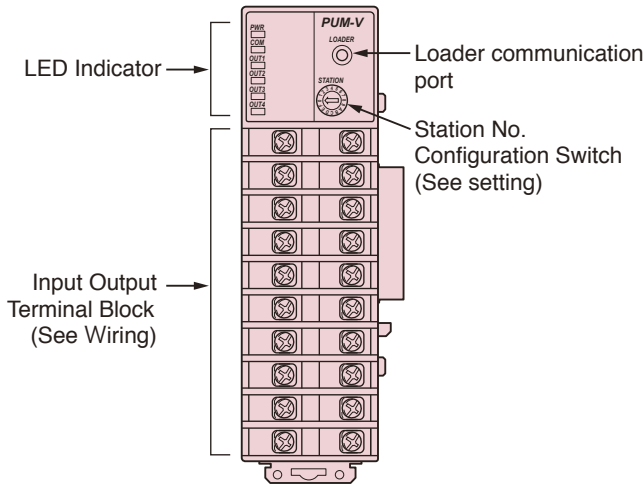

LEDIndicator Six LED lamps indicate the following operational conditions

LED	LED Status	Color	Operational condition
PWR	Illuminated	green	Normal operation (Slave station of internal communication)
	Blinking	green	Normal operation (Master station of internal communication)
	Illuminated	red	System fault (A/D converter error, internal communication error)
	Blinking	red	Input error
COM	Illuminated	green	RS485 receiving
	Illuminated	orange	RS485 transmitting
OUT1-4	Illuminated	green	corresponding channel outputting *1
	Illuminated	red	Corresponding channel input error *2

Actions to be displayed for COM and OUT1-4 can be allocated with using parameter

*1 Illuminated green is not available for model PUMN

*2 Illuminated red is not available for model PUMT

CODE: PUMCL

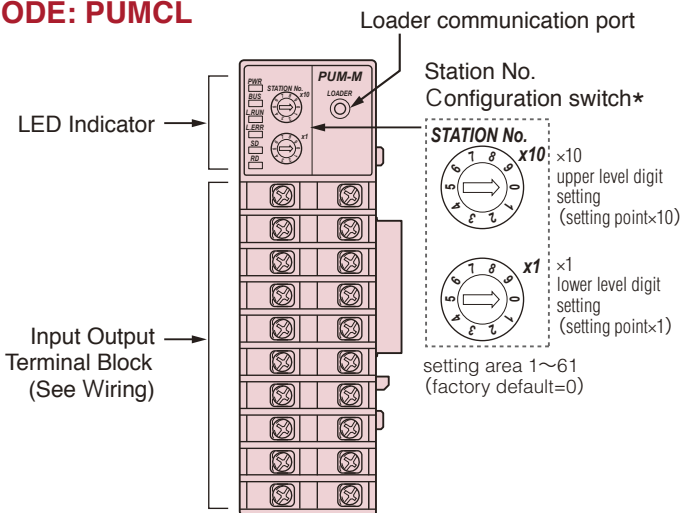

LEDIndicator Six LED lamps indicate the following operational conditions

LED	LED Status	Color	Operational condition
PWR	Illuminated	green	RUN
	Illuminated	red	Error
BUS	Illuminated	green	Internal bus transmitting
	Illuminated	orange	Internal bus receiving
LRUN	Illuminated	green	CC-Link normal operation
	Slow Blinking	green	CC-Link error
	Fast Blinking	green	CC-Link communication initialization
LERR	Illuminated	red	CC-Link setting error
	Slow Blinking	red	CC-Link operation error
	Fast Blinking	red	CC-Link chang setting
SD	Illuminated	green	CC-Link transmitting
RD	Illuminated	green	CC-Link receiving

*Appearing cannot do the communication of CC-Link as factory default(0)
Set a station No. by all means

CODE: PUMCR/M

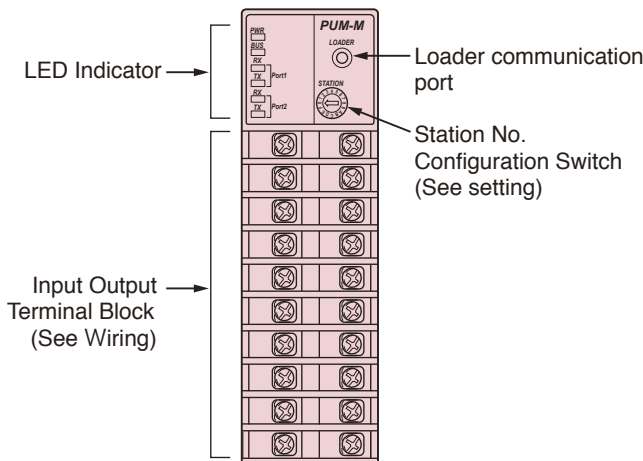

LEDIndicator Six LED lamps indicate the following operational conditions

LED	LED Status	Color	Operational condition
PWR	Illuminated	green	RUN
	Illuminated	red	Error
BUS	Illuminated	green	Internal bus transmitting
	Illuminated	orange	Internal bus receiving
RXPort1	Illuminated	green	Port1 receiving
TXPort1	Illuminated	orange	Port1 transmitting
RXPort2	Illuminated	green	Port2 receiving
TXPort2	Illuminated	orange	Port2 transmitting

WIRING

Base part

CODE: PUMA/B/V/N/T/C COMMON

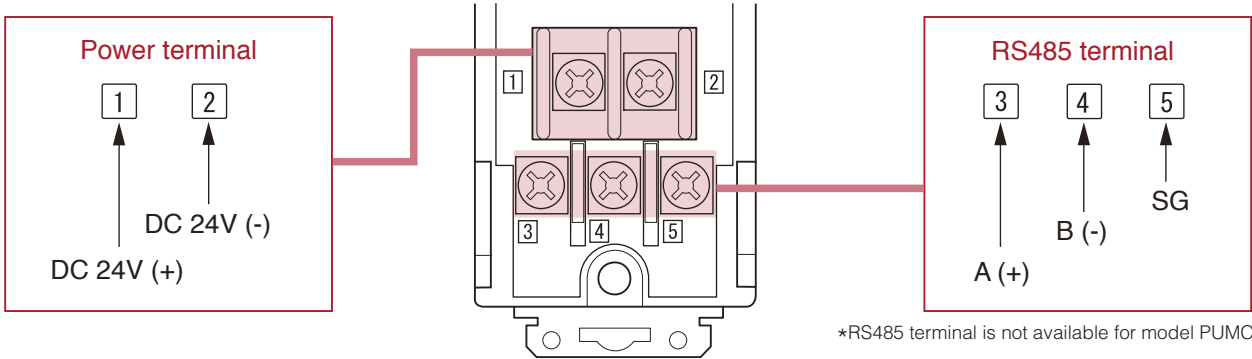

Front terminal block

CODE: PUMA

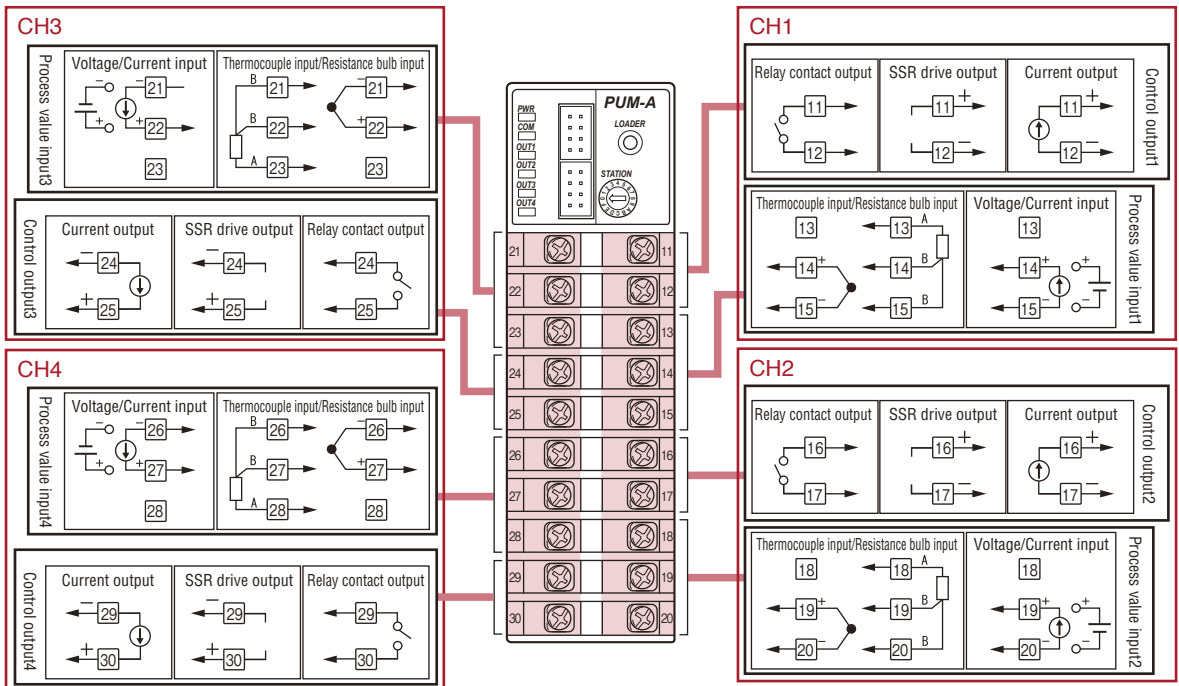

CODE: PUMB

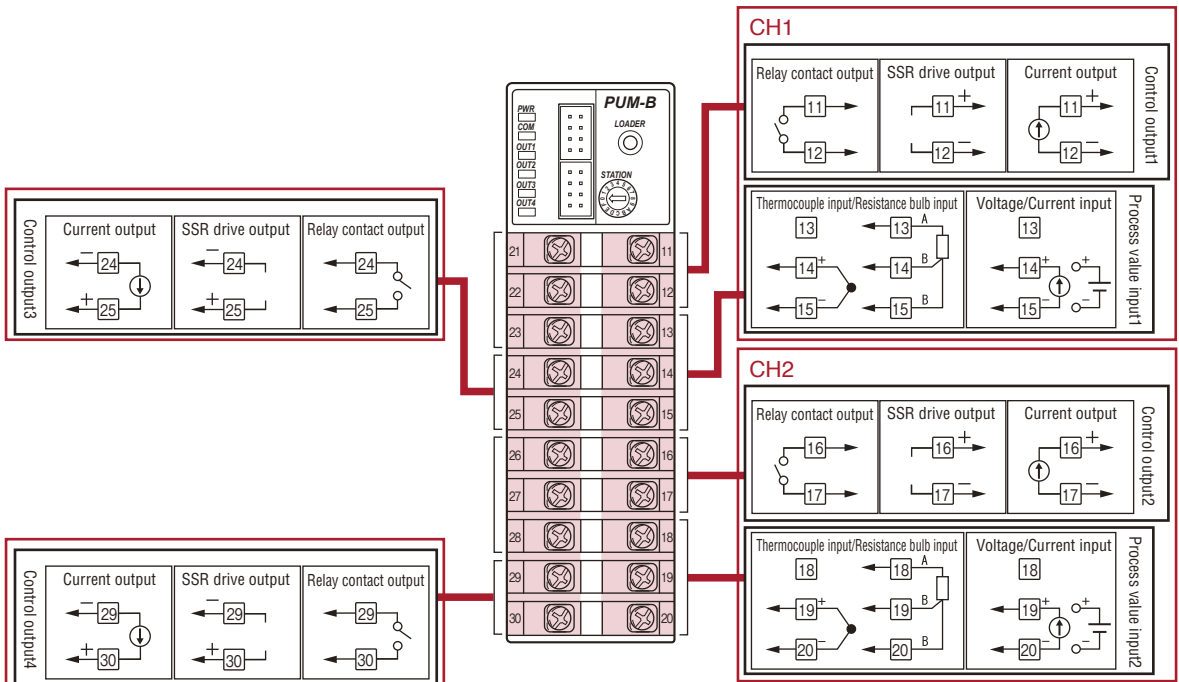

* Pin No. 2,4,6,8 of CN1 and CN2 are connected inside the equipment.
 * CN2 cannot be used for PUMB

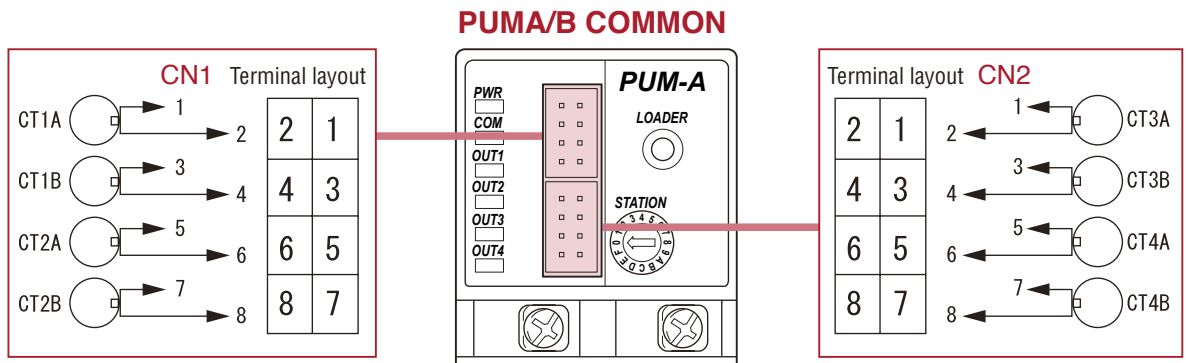

CODE: PUME

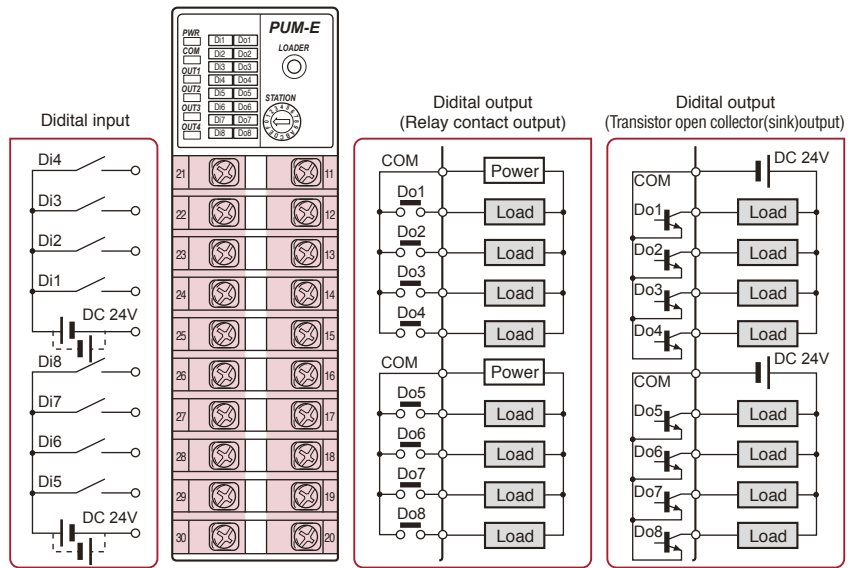

CODE: PUMV/NT

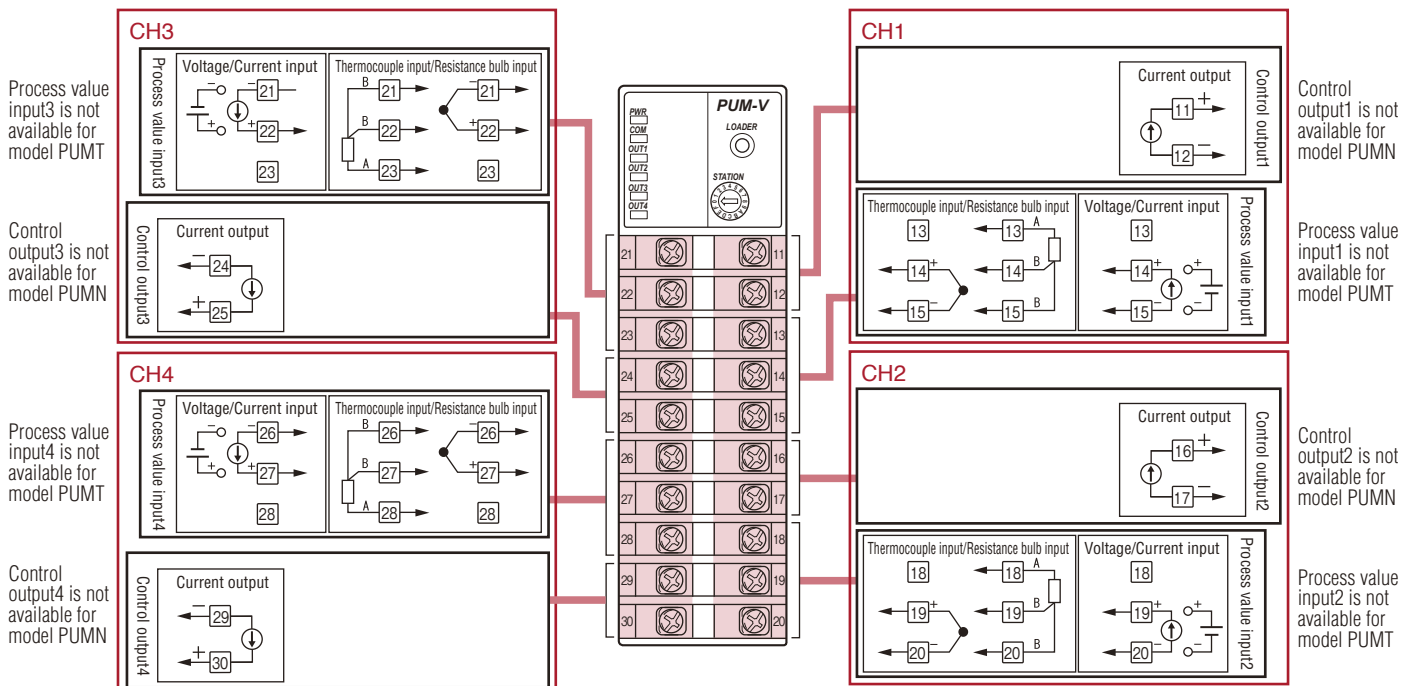

CODE: PUMCL

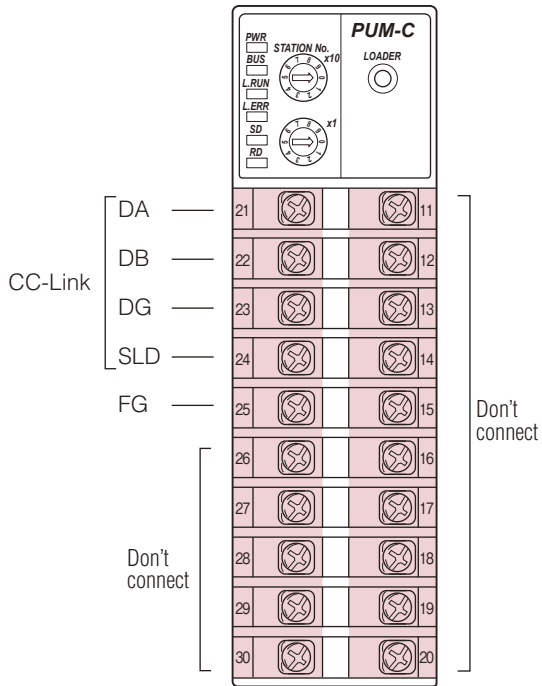

CODE: PUMCR/M

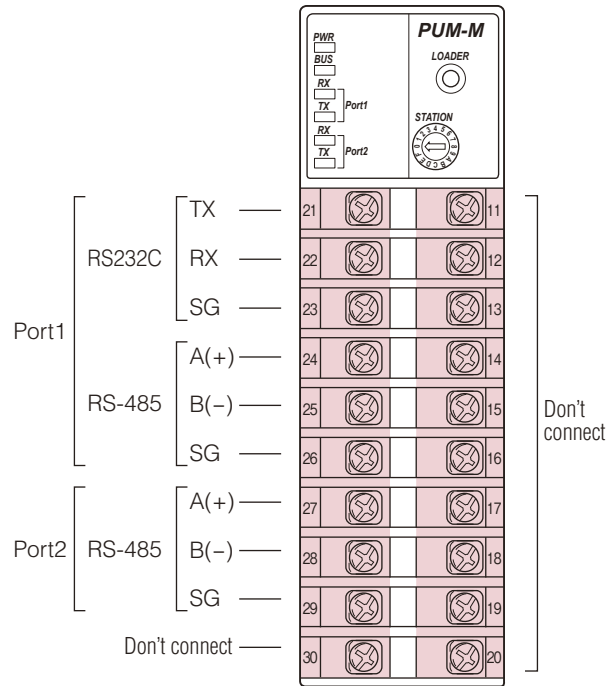

○ SIMPLE PARAMETER LIST FOR PUMA/B

Parameter name	Read/Write date setting range	Factory default	Registor No 1 (Ch1)	Registor No 2 (Ch2)	Registor No 3 (Ch3)	Registor No 4 (Ch4)
Operation parameters						
SV value	0 to 100%FS	0%FS	40001	40002	40003	40004
MV value (%)	-3.0 to 103.0%	—	40005	40006	40007	40008
Manual mode switch	0: Auto 1: Manual	0 (Auto)	40013	40014	40015	40016
Control (PID) parameters						
Proportional band (P)	0.0 to 999.9%	5.0%	41102	42102	43102	44102
Integration time (I)	0 to 3200sec	240sec	41103	42103	43103	44103
Derivation time (D)	0.0 to 999.9sec	60.0sec	41104	42104	43104	44104
ON/OFF control hysteresis	0.00 to 50.00%FS	1°C	41105	42105	43105	44105
Setup parameters						
PV1/PV2/PV3/PV4 input type	0 : JPt100 (0-150) 1 : JPt100 (-150-600) 2 : Pt100 (0-150) 3 : Pt100 (-150-300) 4 : Pt100 (-150-850) 5 : J (0-400) 6 : J (0-800) 7 : K (0-400) 8 : K (0-800) 9 : K (0-1200) 10 : R (0-1600) 11 : B (0-1800) 12 : S (0-1600) 13 : T (-199-400) 14 : E (-199-800) 18 : N (0-1300) 19 : PL-2 (0-1300)	7	40151	40152	40153	40154
Decimal place	0: No decimal point 1: One decimal point	1	41214	42214	43214	44214
System parameters						
CH1 Output proportion cycle	1 to 120sec	30sec	40176	—	—	—
CH2 Output proportion cycle	1 to 120sec	30sec	40182	—	—	—
CH3 Output proportion cycle	1 to 120sec	30sec	40188	—	—	—
CH4 Output proportion cycle	1 to 120sec	30sec	40194	—	—	—
ON/OFF hysteresis setting	0: OFF 1: ON	1 (ON)	41292	42292	43292	44292
Communication parameters						
RS485 Parity setting	0: NONE 1: ODD 2: EVEN	0	40111	—	—	—
RS485 Communication speed	0: 9600bps 1: 19.2kbps 2: 38.4kbps 3: Forbidden 4: 115.2kbps	1	40115	—	—	—
RS485 Communication permission	0: Read only 1: Read/Write	1 (R/W)	40114	—	—	—
Master/slave setting in connected	0: Master 1: Slave	1 (Slave)	40117	—	—	—
Monitor parameters						
Measurement value (PV)	-5.0 to 105.0%FS	—	30002	30003	30004	30005
Set value (SV)	0.0 to 100.0%FS	—	30006	30007	30008	30009
Output value (MV1)	-3.0 to 103.0%	—	30014	30016	30018	30020

CODE SYMBOLS

Control module (4channels)

Digit	Description	PUM
4	<Module type> 4ch control module	4 5 6 7 8 9 10 11 12 13 A ↓
5	<Input type> Thermocouple /Resistance bulb (all channels) Voltage/current (all channels) Thermocouple/Resistance bulb (ch1,2), voltage/current (ch3,4)	T ↓ A ↓ C ↓
6	<OUT1, 2 output type> Relay output SSR drive output Current output Note 1	A ↓ C ↓ E ↓
7	<OUT3, 4 output type> Relay output SSR drive output Current output Note 1	A ↓ C ↓ E ↓
8	<Version No.>	1 ↓
10	<Operation Manual> Japanese English	A ↓ B ↓
11	<Option> Not fitted CT input (8 points) Note 2	Y ↓ C ↓

Note1) It is impossible to combine "C" in the 11th digits

Note2) It is possible to combine "E" in the 6th/7th digits

Control module (2channels)

Digit	Description	PUM
4	<Module type> 2ch control module	4 5 6 7 8 9 10 11 12 13 B ↓
5	<Input type> Thermocouple/Resistance bulb (all channels) Voltage/current (all channels)	T ↓ A ↓
6	<OUT1, 2 output type> Relay output SSR drive output Current output Note 1	A ↓ C ↓ E ↓
7	<OUT3, 4 output type> Relay output SSR drive output Current output Note 2 Note 3	A ↓ C ↓ E ↓
8	<Version No.>	1 ↓
10	<Operation Manual> Japanese English	A ↓ B ↓
11	<Option> Not fitted CT input (8 points) Note 4	Y ↓ C ↓

Note1) It is impossible to combine "C" in the 11th digits

Note2) You need OUT3/OUT4 for the heating/cooling control

Event input/output module

Digit	Description	PUM
4	<Module type> Event input/output module (Di 8 points/Do 8 points)	4 5 6 7 8 9 10 11 12 13 E ↓
5	<Input type> Transistor open collector (sink) output Relay contact output	C ↓ R ↓
8	<Version No.>	1 ↓
10	<Operation Manual> Japanese English	A ↓ B ↓

Input/output analog module

Digit	Description	PUM
4	<Module type> analog input/output module AI4/AO4 analog input module AI4 analog output module AO4	4 5 6 7 8 9 10 11 12 13 V ↓ N ↓ T ↓
5	<Input type> Note 1 Input: Thermocouple /Resistance bulb (all channels) Note 1 Input: Voltage/current (all channels) Note 1 Input: Thermocouple /Resistance bulb (ch1,2) Voltage/current (ch3,4) Note 2 Analog output module	T ↓ A ↓ C ↓ Y ↓
6	<OUT1, 2 output type> Note 3 None Note 2 Current output	Y ↓ E ↓
7	<OUT3, 4 output type> Note 3 None Note 2 Current output	Y ↓ E ↓
8	<Version No.>	1 ↓
10	<Operation Manual> Japanese English	A ↓ B ↓

Note1) You can select only "V, N" in the 4th

Note2) You can select only "V, T" in the 4th

Note3) You can select only "N" in the 4th

Enhanced communication module

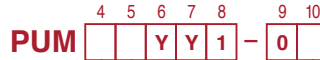

Digit	Description	
4	<Module type>	enhanced communication modul
5	<Communication module>	RS-485 High-speed communication MITSUBISHI –PLC Program-less communication CC-Link communication
8	<Version No.>	1
10	<Operation Manual>	Japanese English

Accessories



Digit	Description	
6	RS485 terminating resistance	A 0 1
7	Note1 DIN rail mounting end plate	A 0 2
8	Note1 Side connecting terminal cover (right & left 1set)	A 0 3
	Note1 Front face screw terminal cover	A 0 4
	Note2 Loader connecting cable (RS232C)	L 0 1
	Note3 CT input terminal cable (for 4 points) (l=1m)	C 0 1
	Note3 CT input terminal cable (for 4 points) (l=3m)	C 0 3
	Note3 CT input terminal cable (for 4 points) (l=5m)	C 0 5
	CT for 1 to 30A (CTL-6-S-H)	C T 1
	CT for 20 to 50A (CTL-12-S36-8)	C T 2

Note1) Only 10 unit for your order
 Note2) It is necessary for using USB port to repairer the "USB-Serial" convert
 Note3) The cable of CT input is minimum unit that 3-phase and 2 channels

ACCESSORIES

Heater current detector (CT)

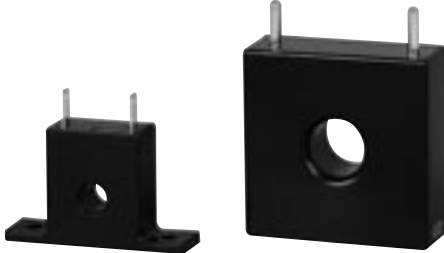

General specification

	For 1 to 30A	For 20 to 50A
Type	CTL-6-S-H	CTL-12-S36-8
Dimension (HxWxD mm)	25x40x10	40x40x15
Through-bore (mm)	φ5.8	φ12

Outline Diagram (unit:mm)

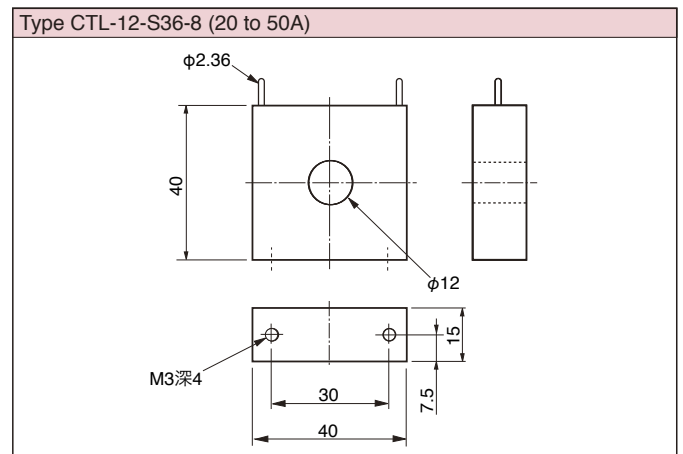
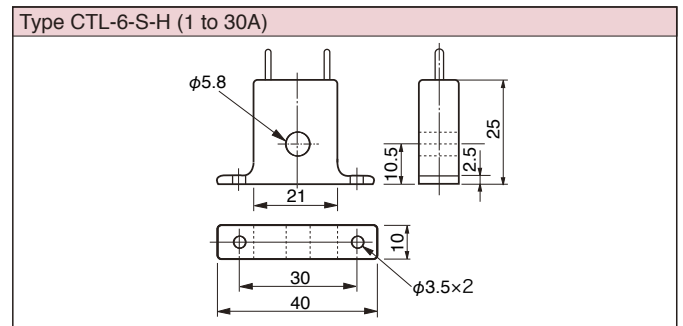

PERIPHERAL INSTRUMENTS

● Programmable Operation Display

Name	type	specification	
UG530series 12.1 type	UG530H-VS1	TFT Color liquid crystal	AC110-200V
	UG530H-VH1	SVGA	Ethernet normal deployment,option unit equipped
	UG530H-VS4		DC24V
	UG530H-VH4		Ethernet normal deployment,option unit equipped
UG430series 10.4 type	UG430H-TS1	TFT Color liquid crystal	AC110-200V
	UG430H-TH1	VGA	Ethernet normal deployment,option unit equipped
	UG430H-TS4		DC24V
	UG430H-TH4		Ethernet normal deployment,option unit equipped
	UG430H-VS1	TFT Color liquid crystal	AC110-200V
	UG430H-VH1	SVGA	Ethernet normal deployment,option unit equipped
	UG430H-VS4		DC24V
	UG430H-VH4		Ethernet normal deployment,option unit equipped
	UG430H-SS1	TFT Color liquid crystal	AC110-200V
	UG430H-SS4	VGA128 color type	DC24V
	UG430H-VH1B	separate-type SVGA	Ethernet normal deployment,option unit equipped
	UG430H-VH4B		DC24V

● Thyristor Units

PT3000S-1PH / / / / / / /

digit		specification	type code
1st	<Rated current>	15A 25A 35A 45A 60A 90A 110A	15A 25A 35A 45A 60A 90A 110A
2nd	<Rated voltage>	Customer specifications	
3rd	<Maximum voltage>	240V	240V
4th	<Auxiliary voltage>	none 230V 460V	NONE 230V 460V
5th	Input	SSR 110V/ON/OFF 230V/ON/OFF Note1 4-20mA loop power	SSR 110A 230V LP4-20MA
6th	Firing	Zero crossing Note2 Bust Firing	ZC BF
7th	option	Note3 External fuse (Less than 90A) Note3 Internal fuse (More than 110A) Heater break alarm Fan110V	EF 1F HB 110VFAN

Note1) Available from 15 to 110A
 Note2) Select "BF04", "BF08", or "BF15"
 Note3) Select "EF" or "1F"

● Automation software CITECT

PAT

digit		specification	type code
4	<type of license key> Note1	software (no license key)	YY
5	<I/O points>	full license key 75points full license key 150points full license key 500points full license key 1,500points full license key 5,000points full license key 10,000points full license key 15,000points full license key 30,000points full license key 50,000points full license key 150,000points	FA FB FC FD FE FK FF FJ FG FH

Optimum multiple-zone controller (If you need more than eight control zones, please contact us.)

Optimum multiple-zone controller (Patent pending)

- It applies to the control systems with mutual interference of multiple-zone
- It applies to the case that interference for temperature control between zones occurs, as the case of reflow furnace

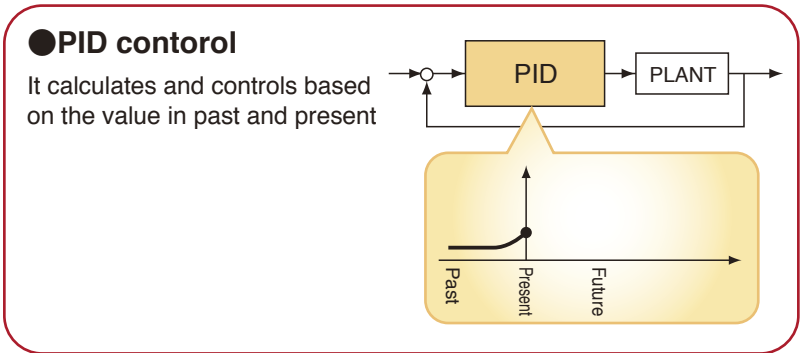
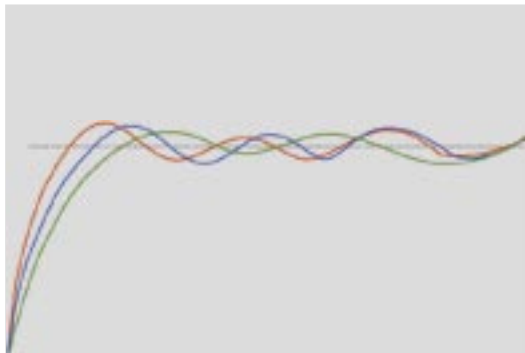

Optimum multi-zone control by Fuji' s original algorithm

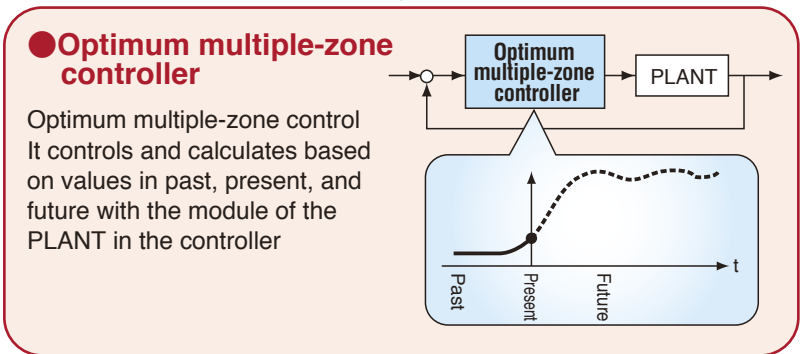
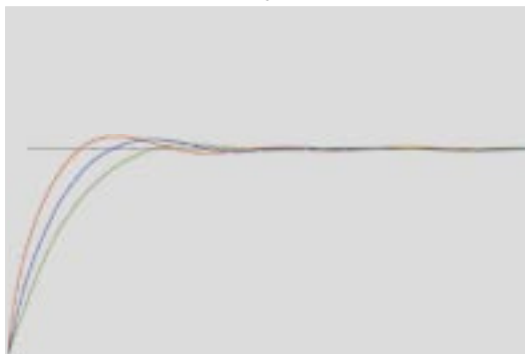

System constitution

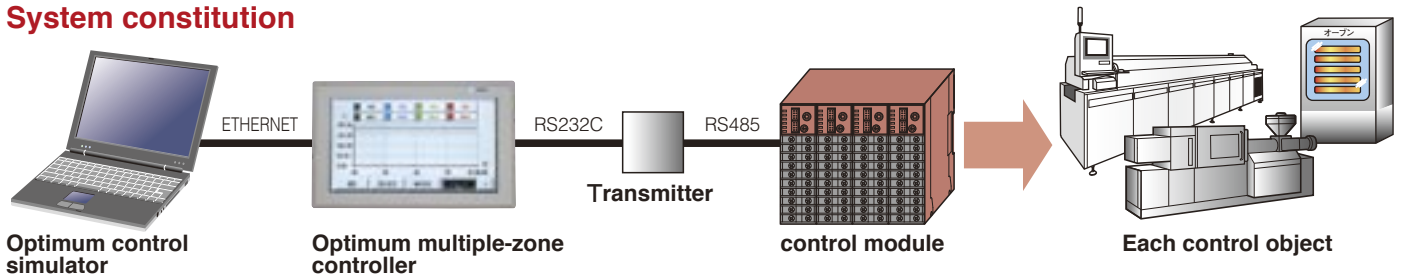

PC environment for Optimum control simulator

OS	Windows 2000/XP
CPU	more than 500MHz
HD	more than 100MB (Space capacity)
CR-ROM	Need
MONITOR	more than 1280x1024

Specifications (Optimum multiple-zone controller)

Power supply	DC24V (DC20.4V to 26.4)
Power consumption	less than 7w
OS	Linux
CPU	SH-7760 192MHz
SDRAM	64Mbyte
Higher communication	ETHERNET
Lower communication	RS232C

Outline diagram (Optimum multiple-zone controller)

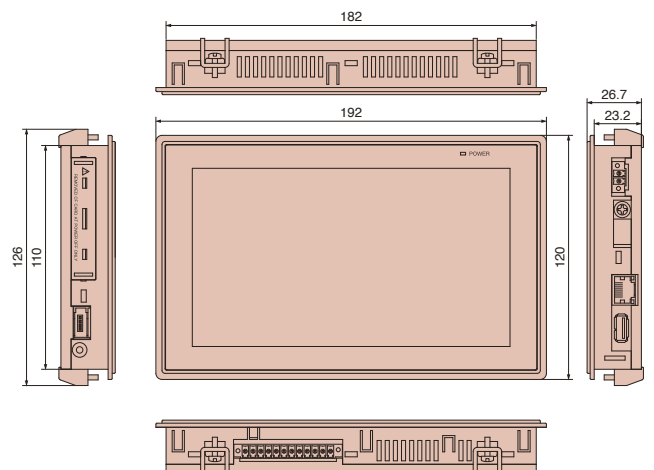

PERIPHERAL INSTRUMENTS

Programmable Operation Display

Meet our POD. The display that makes your machines more attractive, and your system configuration more simple

Expressive
Integrative
Supportive
Connective
Resources
Creative

15_{type} XGA
16,777,216
True-Color Video Display

POD UG Series

POD Satisfies Varieties of Needs





Expression

Impressive, real expression of photos and illustrations 32,768 full-color images as standard specification

Expressive

Possible 32,768 full-color images for all sizes from 5.7 to 15.0 types. Improved image quality will enhance the machine and system values.





Information Management

CF card usable for data from all sources covering the PC and PLC

Supportive

Data of PC can be shared with PLC or vice versa by using the CF card. In addition, screen data and all other POD data can be saved into the CF card, and the CF card can be loaded into the POD.





Conforms to 32,768 full-color for clearer and sharper image display. Simplifies your system as a gateway of the temperature control network that connects the PLC, temperature controllers, and inverters. The UG series are the displays that best fit users' needs by providing clearer and sharper images and allowing simplified system configuration.



Maintenance Tool

Supporting on-site maintenance with the convenient maintenance tool

Resources

The on-site maintenance is strongly supported by the CF card for screen management and the PLC program data read/write using the ladder transfer function.



Editor

Easy creation of original screens meeting on-site needs with plentiful functions

Creative

Wizard function permits faster and sharper screen creation. The multilingual edit function easily creates not only English Date Screen but Data Screen, usable worldwide.

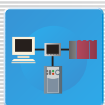

Network

Conforms to all types of networks, from open network to Ethernet.

Integrative

By using the Ethernet as the standard, a network system with the POD acting as the core can be easily configured. Temperature control network permits direct access to an inverter or temperature controller while connecting to the PLC; thus, reducing the PLC load.



External Connection

A variety of interfaces with external units is the standard.

Connective

Higher functions and cost reduction of machine or equipment can be achieved by the video input and RGB I/O functions. In addition to screen data transmission, connection with printer and card reader/writer is possible by using the USB master/slave interface.



Fuji Electric Systems Co., Ltd.

Head Office

Gate City Ohsaki, East Tower,
11-2, Osaki 1-chome, Shinagawa-ku, Tokyo 141-0032, Japan
<http://www.fesys.co.jp/eng>

Instrumentation Div.

International Sales Dept.

No.1 , Fuji-machi, Hino-city, Tokyo,191-8502 Japan
Phone : 81-42-585-6201,6202
Fax : 81-42-585-6187
<http://www.fic-net.jp/eng>